



Operator Manual

Central Mobile Enclosure
200 GTS



S.N. 170901-

DRYAIR Manufacturing Corp.
Box 126, 400 Service Road
St. Brieux, SK, Canada
S0K 3V0

Tel: (306) 275-4848 1-888-750-1700

Fax: (306) 275-4664

Table of Contents

1. Warranty Policies & Claim Procedures.....	1-6
Warranty Policies.....	1-6
Basic Warranty Policy.....	1-6
Extended Warranty Policy.....	1-6
Heat Exchanger.....	1-6
Exceptions to the Warranty Policies.....	1-6
Owner Obligations.....	1-7
Manufacturer Obligations.....	1-7
Warranty Claim Procedure.....	1-7
2. Safety Concerns.....	2-1
General Safety Guidelines.....	2-1
Water Heater Module.....	2-2
Heat Transfer Fluid (HTF).....	2-2
Fluid Handling Precautions.....	2-2
First Aid Measures.....	2-2
Trailer Safety.....	2-3
3. Introduction.....	3-1
Components.....	3-1
Accessories.....	3-2
Extension Reservoir Assembly.....	3-2
Mixing/Booster Pump.....	3-2
Optional Remote Manifold.....	3-3
Insulated Line Jackets.....	3-3
Portable Heat Exchangers.....	3-3
Plate Heat Exchanger.....	3-3
How the System Works.....	3-4
Flow Reverser (<i>if equipped</i>).....	3-5
4. Setup.....	4-1
Lifting the Unit.....	4-1
Prerequisites.....	4-1
Tie-Down.....	4-2
Prerequisites.....	4-2
Required Safety Clearances.....	4-3
Elevation Concerns.....	4-3
Electrical Requirements & Connection.....	4-4
Heat Transfer Fluid (HTF).....	4-4
Fuel.....	4-5
Primary "HTF" Circulation Lines.....	4-5
Burner Removal.....	4-6
Burner Installation.....	4-6
5. Operation.....	5-1

Purging Air from the "HTF" Circulation System.....	5-1
Before Firing the System.....	5-1
Temperate Start Procedure	5-1
Cold Start Procedure	5-2
Extreme Cold Start Procedure	5-3
Adding "HTF" to System.....	5-4
Purging Air from the Fuel System	5-5
6. Hose Reel.....	6-1
Unloading	6-1
Loading.....	6-1
Secondary Fluid Containment	6-2
Shut-Down Procedure	6-2
Transportation	6-3
7. Troubleshooting	7-1
Troubleshooting (CME).....	7-1
Troubleshooting Hose Reel	7-3
8. Maintenance.....	8-1
Daily Checklist	8-1
Seasonal Checklist	8-1
Hose Reel	8-2
9. Appendix.....	9-1
Important Certification & Operational Information Decals.....	9-1
Non-Pressure Vessel Decal	9-1
Certification & Heater Specifications.....	9-2
Electrical Schematics.....	9-3
Hose Reel Schematic	9-5
Trailer Schematics.....	9-5
Heat Transfer Fluid Preheater Information	9-7
Material Safety Data Sheets	9-9

Table of Figures

Figure 1 - Safety Decals.....	2-1
Figure 2 - Trailer Coupler.....	2-3
Figure 3 - 200 GTS Central Mobile Enclosure.....	3-1
Figure 4 - 200 GTS Central Mobile Enclosure (Hose Reel Access Open).....	3-1
Figure 5 - Circulation Lines.....	3-1
Figure 6 - Extended Reservoir Tank.....	3-2
Figure 7 - Mixing/Booster Unit.....	3-2
Figure 8 - Optional Remote Manifold.....	3-3
Figure 9 - Portable Heat Exchangers.....	3-3
Figure 10 - Plate Heat Exchanger Unit.....	3-3
Figure 11 - How the System Works.....	3-4
Figure 12 - Flow Reverser Technology, Even Thaw Pattern.....	3-5
Figure 13 - Without Flow Reverser Technology, Uneven Thaw Pattern.....	3-5
Figure 14 - Lifting Points.....	4-1
Figure 15 - Sling 4x7' (Part# 017-904702).....	4-1
Figure 16 - Lifting Sling Angles.....	4-1
Figure 17 - Tie-Down Points.....	4-2
Figure 18 - Top-View Clearances.....	4-3
Figure 19 - Side-View Clearance.....	4-3
Figure 20 - Power Connections.....	4-4
Figure 21 - NEMA 5-15 Wiring.....	4-4
Figure 22 - Glycol Mixing Guide.....	4-5
Figure 23 - Camlock Couplers.....	4-6
Figure 24 - Riello Burner Front.....	4-6
Figure 25 - Riello Burner Side (Fuel Lines).....	4-6
Figure 26 - Riello Burner Top.....	4-6
Figure 27 - HTF Level Indicator.....	5-1
Figure 28 - Circulation Manifold.....	5-1
Figure 29 - Control Panel Switches.....	5-1
Figure 30 - System Pressure Gauge.....	5-1
Figure 31 - Fuel Shutoff Valve (Closed).....	5-1
Figure 32 - Air Intake Vent.....	5-1
Figure 33 - Control Panel Switches.....	5-2
Figure 34 - Control Panel Gauges.....	5-2
Figure 35 - Pump Isolation Valve.....	5-3
Figure 36 - Fill/Drain Hose.....	5-4
Figure 37 - Pump Connections.....	5-4
Figure 38 - HTF Level Indicator.....	5-4
Figure 39 - Burner Reset Button.....	5-5
Figure 40 - Hose Reel.....	6-1
Figure 41 - Hose Reel Brake.....	6-1
Figure 42 - Clutch Lever Out.....	6-1
Figure 43 - Clutch Lever In.....	6-1

Figure 44 - GFCI Switch6-1
Figure 45 - Foot Switch.....6-2
Figure 46 - Stowed Foot Switch6-2
Figure 47 - Secondary Fluid Containment Drain Plug6-2
Figure 48 - Fuel Shutoff Valve (Closed)6-2
Figure 49 - Hose Reel Door Safety Latch6-3
Figure 50 - Non-Pressure Vessel Decal.....9-1
Figure 51 - Water Heater Data & Serial Plate9-2
Figure 52 - 200 GTS Electrical Schematic.....9-3
Figure 53 - 200 GTS C/W Optional Flow Reverser Electrical Schematic9-4
Figure 54 - Hose Reel Electrical Schematic9-5
Figure 55 - Close-up View of Trailer Hook-up9-5
Figure 56 - Trailer Electrical Schematic9-6
Figure 57 - HTF Preheater9-7

1. Warranty Policies & Claim Procedures

DRYAIR MANUFACTURING CORP. (referred to within as DRYAIR) warrants its new, unused equipment to be free of defects in material and workmanship at the time of delivery to the original retail purchaser.

Warranty Policies

Basic Warranty Policy

- DRYAIR will repair or replace, at its option, without charge, any defective part of the equipment for a period of twenty-four (24) months from delivery to the first retail purchaser, F.O.B St. Brieux, SK., Canada.
- Any parts that are covered by an extended warranty published by DRYAIR are an exception to the Basic Warranty policy and are to be warranted as per the details of the Extended Warranty Policy.
- Labour is covered as per DRYAIR flat labour rate.
- The Warranty Policy, terms and conditions, may change from time to time without prior notice.
- Warranty terms and conditions are transferable in the event of the sale to a second owner.
- Replacement parts will be warranted for 90 days from the repair date. Bill of sale must accompany the warranty claim.
- The terms of this Warranty Policy are subject to provincial and state legislation. DRYAIR reserves the right to make modifications in accordance with provincial and state legislation without prior notice or obligation.

Extended Warranty Policy

Heat Exchanger

- An extended warranty is available on the heat exchanger unit of the water heater assembly. The available warranty for a part, under the extended warranty policy, is prorated by 20% per year.
- Shipment date is the date to be used for the commencement of the warranty period.
- Coverage schedule

Year 1 - 100%

Year 2 - 80%

Year 3 - 60%

Year 4 - 40%

Year 5 - 20%

Exceptions to the Warranty Policies

- Under no circumstance shall the owner be entitled to recover costs for incidental, special or consequential damages such as, but not limited to: loss of profit or revenue, other commercial losses, inconvenience and/or replacement equipment rental cost.
- Maintenance, repair or service items not related to warrantable defects.
- Loss or damage during shipping.

- Failure resulting from lack of or improper maintenance.
- Damage caused by operator abuse, negligence or improper operation.
- Damage resulting from improper voltage supply.
- Damage from improper installation. Installation done by other than the manufacturer.
- Non-defective items replaced at the request of the customer.
- Damage due to accidents.
- Damage resulting from improper fuel supply (i.e. pressure or contamination).
- Damage resulting from cracked or broken lines occurring during transport.
- Damage resulting from use of inadequate or improper fluids (i.e. Glycol or oil).
- Mileage is not covered.
- Glycol is considered a consumable and will not be covered under the warranty policy.
- Generators carry their own warranty coverage through their own manufacturers. Please refer generator issues to the OEM. Contact information may be found in the Service & Operators Manual under Optional Equipment.

Owner Obligations

- It is the responsibility of the owner, at the owner's expense, to transport the equipment to the service facility of an authorized DRYAIR distributor/dealer or alternately to reimburse the distributor/dealer, for any traveling expenses incurred in fulfilling this warranty.
- The terms of this Warranty Policy are subject to provincial and state legislation. DRYAIR reserves the right to make modifications in accordance with provincial and state legislation without prior notice or obligation.
- It is the responsibility of the owner to read, understand and implement the maintenance, safety and operational guidelines as laid out in the Operation and Maintenance Guide.
- All parts are to be tagged with warranty claim number and shipped prepaid to DRYAIR within 30 days.

Manufacturer Obligations

- DRYAIR reserves the right to continually improve the product's parts or specifications at any time without notice or obligation.
- The terms of this Warranty Policy are subject to provincial and state legislation. DRYAIR reserves the right to make modifications in accordance with provincial and state legislation without prior notice or obligation.

Warranty Claim Procedure

- All warranty credits must be processed with the DRYAIR Warranty Claim Form.
- All warranty parts, unless otherwise specified, are to be returned to DRYAIR along with a completed Warranty Claim Form.

Note: *Prior to returning warranty parts, please call for an authorization number and shipping instructions from the Warranty department in Canada.*



Location of Warranty Depots:

USA

DRYAIR Manufacturing Corp.
410 Douglas Road, Box 264
Bradner, OH 43406
Ph. 1 (888) 750-1700

Canada

DRYAIR Manufacturing Corp.
400 Service Road, Box 126
St. Brieux, SK S0K 3V0
Ph. 1 (888) 750-1700

- Each warranty claim should only refer to one Serial or Production Schedule numbered unit.
- Warranty parts are to be tagged with warranty claim number.
- When claiming for warranty labour, the allowable warranty labour rate will be \$85.00/hour. The factory reserves the right to adjust the number of hours claimed where deemed necessary.
- The factory may at times specify allowable labour for certain warranty procedures.
- Mileage and travel time to/from the customer are not eligible for warranty credit.
- Freight charges for warranty parts are not eligible for warranty credit.
- Labour flat rates for component changes:
 - Electrical Components - 0.5hr
 - Relays
 - Switches
 - Thermostats
 - Breakers
 - Plumbing Components - 1hr
 - Flow Reverser
 - Flow Switch
 - Valves
 - Electric Motor Changes - 1hr
 - Hose Reel
 - Glycol Pump Changes - 2hrs

Note: Other labour charges will be at the discretion of DRYAIR.

2. Safety Concerns

General Safety Guidelines

- Make certain that the operator reads and understands all the information in this manual.
- All unauthorized people must be kept away from the equipment when in operation.
- All guards must be in place when the equipment is in operation.
- Maintain instructional and safety decals. Replace damaged decals (Figure 1).



Figure 1 - Safety Decals

Water Heater Module

CAUTION! *The water heater is a heating appliance.*

- Observe all posted warnings and cautions when dealing with any heating appliance.
- Keep children and pets away from all piping and fuel accessories.
- While the system is operating the water heater housing panels must be kept closed to prevent drafts from affecting water heater operation.

The key advantage to the 200 GTS system, in addition to better temperature control abilities over other heating methods, is that there is only one flame point and only one fueling point. This means fewer sets of environmentally sensitive equipment to manage. In the DRYAIR system, the heat transfer around your site is almost entirely managed by low-pressure Heat Transfer Fluid lines.

Heat Transfer Fluid (HTF)

Follow the following precautions and measures when working with “heat transfer fluid” (“DOWFROST* HTF” & “BOSS CHILL PG”).

Fluid Handling Precautions

- Ventilation Good general ventilation should be sufficient for most conditions.
- Respiratory protection No respiratory protection should be needed.
- Skin protection For brief contact, no precautions other than clean, body-covering clothing should be needed.
..... Use impervious gloves when prolonged or frequently repeated contact should occur.
- Eye protection Use safety glasses.

First Aid Measures

- Eyes Flush eyes with plenty of water.
- Skin Wash off in flowing water or shower.
- Ingestion Induce vomiting if large amounts are ingested.
..... Consult medical personnel.
- Inhalation Remove to fresh air if effects occur.
..... Consult a physician.
- Note to Physician No specific antidote.
..... Supportive care.
..... Treatment based on judgment of the physician in response to reactions of the patient.

For complete “heat transfer fluid” information, refer to the Material Safety Data Sheets for “Dowfrost HTF” & “Boss Chill PG” included with the manuals package

Trailer Safety

DRYAIR trailers are equipped with torsion single or tandem axles with electric brakes on each axle. It is necessary to tow units with tandem axles as parallel as possible to the road to ensure equal loading on each axle. The tow vehicle must be equipped with a brake controller for the electric brakes to function.

The tow vehicle operator is responsible for the following:

- Ensure that all the tires are inflated to the manufacturer’s specifications.
- Check the tire tread on all tires for indications of wear or misalignment.
- Test the signal lights, brake lights, and park lights for proper operation.
- Ensure that all tire lug nuts are properly torqued to 120 ft·lb.
- The operator must make sure that the brakes are functioning correctly.
- Before towing, the operator of the tow vehicle must ensure that the trailer is hooked correctly to the tow vehicle (*Figure 2*) including:
 - Safety chains
 - Breakaway cable
 - Electrical connection (lights, brakes)
 - Ensuring that the trailer tongue is properly fastened to the trailer frame

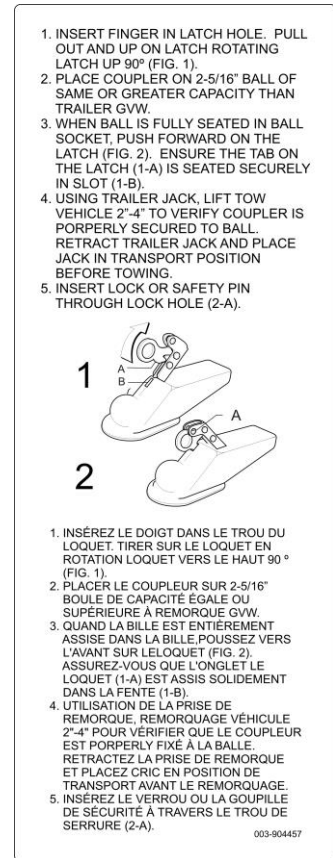

Figure 2 - Trailer Coupler

3. Introduction

Components

Central Mobile Enclosure (CME)

- A compact and portable design.
- Integral secondary fluid containment.
- Easy access from side doors.
- Automatic temperature control and fuel usage, which responds to worksite demands.
- Low-pressure, atmospherically vented circulation system, therefore no special boiler certification is required to operate the system.
- Circulation system "automatic air vent" component for quick setup-and-go operation.
- A central heat module control center which monitors and controls system operations.
- A multi-light system operation feature for easy system troubleshooting.
- Flow-reversing Greenthaw™ system (if equipped).

Hose Reel

- The "live" on board hose reel comes with 1,200ft (2 x 600ft) of ¾" I.D circulation line heat exchange hose.
- Hose can be heated prior to and during deployment and while stowing for added ease of hose handling.
- The reel provides convenient storage for the "circulation line heat exchange" hose required for thawing and/or curing concrete.
- The electric drive system provides "power on" capability.
- The on-board reel comes with an integral 2-port manifold.

Fluid Circulation Lines

Fluid circulation lines are designed to endure the toughest worksite environment. Portable distribution manifolds connected to the primary circulation system redistribute the heat transfer fluid through secondary lines. All fluid circulation components come with isolation valves and quick couplers, ensuring quick set up and start up, and quick disassembly when the job is done. DRYAIR provides a full range of hoses, adapters, and manifolds for handling and distributing HTF.



Figure 3 - 200 GTS Central Mobile Enclosure



Figure 4 - 200 GTS Central Mobile Enclosure (Hose Reel Access Open)



Figure 5 - Circulation Lines

The circulation line heat exchangers are the perfect solution for:

- Heating and/or thawing cold or frozen ground.
- Frost prevention.
- Concrete curing and heating in sub-zero environments.
- Hose loops are typically 500ft in length with maximum of 1,000ft achieved by connecting two hoses together. Refer to the Components, Hose Reel section of the Operator Manual to verify hose length for your unit.

This system can be applied to all types of concrete applications. Circulation line heat exchangers can be secured directly against the surface of the concrete or concrete forms. Alternatively, an expendable circulation line can be incorporated into the concrete structure during the pour. Thus the slab floor can continue being heated, to provide radiant floor heat during construction.

Accessories

Extension Reservoir Assembly

The Extended Reservoir Tank is required in scenarios when “portable heat exchangers” are higher than the top level of the 200 GTS glycol reservoir tank. If the Extended Reservoir tank is not used, the following can occur:

- **Insufficient Fluid in the System**

Fluid can drain back to the heat transfer reservoir tank from the over-elevated fluid lines when the pump is shut off. The heat transfer reservoir tank will show adequate fluid, but when the pump is started, extra fluid will be required to recharge the over-elevated fluid lines and portable heat exchangers and the system will then have insufficient fluid in the reservoir.

- **Fluid Overflow**

If fluid is added to maintain proper fluid levels while the pump is running, overflow at the reservoir tank may occur when the pump is shut off. This would occur because of the drain back from the over-elevated fluid lines.



Figure 6 - Extended Reservoir Tank

Mixing/Booster Pump

The multifunctional Mixing/Booster ensures maximum flexibility in the use of this system.

- Tempering mode supplies lower temperature fluid for concrete cure and radiant floor heat applications eliminating the need to reduce the water heater operating temperatures below safe operating ranges.
- When operating in booster mode the system can increase flow rates or function as a pumping station to increase pumping distances by over 300ft. per station.
- The system also allows for dual-temperature control. High temperature fluid can be provided to portable heat exchangers, along with a lower temperature fluid for concrete cure and radiant floor heat applications.
- The multifunctional Mixing Booster ensures maximum flexibility in the use of this system.



Figure 7 - Mixing/Booster Unit

Note: Disengage Flow Reverser when using this accessory.

Optional Remote Manifold

- The optional remote manifold allows for additional distribution and/or separation between the central heating trailer and the manifold.



Figure 8 - Optional Remote Manifold

Insulated Line Jackets

- Insulated circulation line jackets are also available. These insulated jackets will prevent exposed circulation line heat loss in extreme sub-zero conditions.

Portable Heat Exchangers

Portable heat exchangers are the ideal way to heat and/or dry enclosed structures. Their compact and mobile design allows them to be positioned where they are required on the job site. The efficient fan/coil design provides a high rate of heat transfer. High volume fans then deliver this heat evenly throughout a large area. The clean, low relative humidity heat delivery minimizes energy costs by eliminating the need to draw in fresh outside air. With the DRYAIR system, you just reheat warm internal air, rather than heating cold external air.



Figure 9 - Portable Heat Exchangers

Note: Disengage Flow Reverser when using this accessory.

Plate Heat Exchanger

The Plate Heat Exchanger module creates two separate fluid loops. It can extend the range of the HTF distribution and eliminate the need for extended reservoirs in elevated applications. The plate heat exchanger, combined with a central heating module can be used:

- To extend the effective range and lengths of the primary distribution lines.
- In a multi-story application to extend the vertical distance from the heating module that a portable heat exchanger.



Figure 10 - Plate Heat Exchanger Unit

Note: Disengage Flow Reverser when using this accessory.

How the System Works

The system uses a low-pressure, open fluid loop distribution system with an atmospherically vented fluid reservoir. A central heating module warms the heat transfer fluid. This heated fluid is pumped through a distribution system loop, passing through heat exchangers in remote locations.

Two types of exchangers are available:

- Portable heat exchangers include a heat transfer coil, fan and thermostatic temperature control. The heat transfer fluid flows through the transfer coil, where heat is transferred to the air being drawn through the coil by the fan. The coil is specially designed for optimum heat transfer, without adding any moisture or combustion by-products to the air.
- Circulation line heat exchangers use flexible hose with hydraulic-style quick-couplers for ease in hookup. Heat transfer occurs by direct contact and radiant heat conduction.

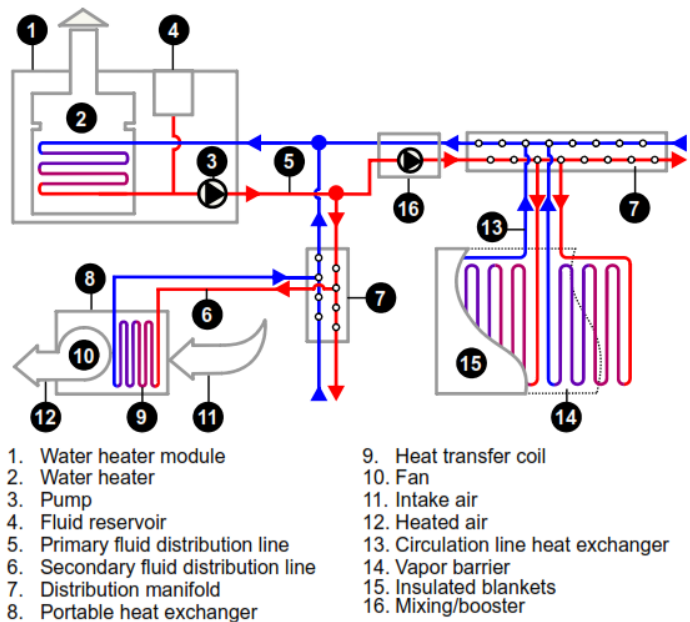

Figure 11 - How the System Works

The Mixing/Booster unit can be utilized to:

- Provide lower temperature fluid for concrete cure and radiant floor heat applications.
- Provide dual temperature control with a single fluid circulation system.
- Boost fluid flow and increase pumping distances.

Flow Reverser (if equipped)

The patented “Smart Thaw” flow reverser allows the Greenthaw™ to thaw ground in half the time of conventional systems, while also providing tighter temperature control, and more even heat distribution, on sensitive concrete curing applications. This device provides an even thaw/cure pattern throughout your ground thaw loop, which in turn speeds up the thawing process, reduces costs and maximizes the unit’s potential.

- The Dryair Greenthaw™ system maximizes every ounce of the energy it uses by directing heat across the thaw grid in a systematic manner that results in a uniform thaw pattern.
- Other systems use circulation loops that move fluid in one direction only. As heat transfer occurs the fluid will cool down as much as 45% as it moves towards the end of the loop. This will result in an uneven thaw pattern. Therefore, while the ground under the warm end continues to be heated, energy is wasted well after it has been thawed due to the colder end of the loop falling behind by as much as 75%. This forces you to thaw for several days longer... needlessly costing you extra time and fuel.
- DRYAIR’s patented Greenthaw™ system maximizes your costly energy by reversing fluid flow on a selected schedule. This means that every square foot of ground sees the same amount of energy giving you an almost perfect thaw pattern... and more importantly, saving you valuable time and reducing energy requirements.

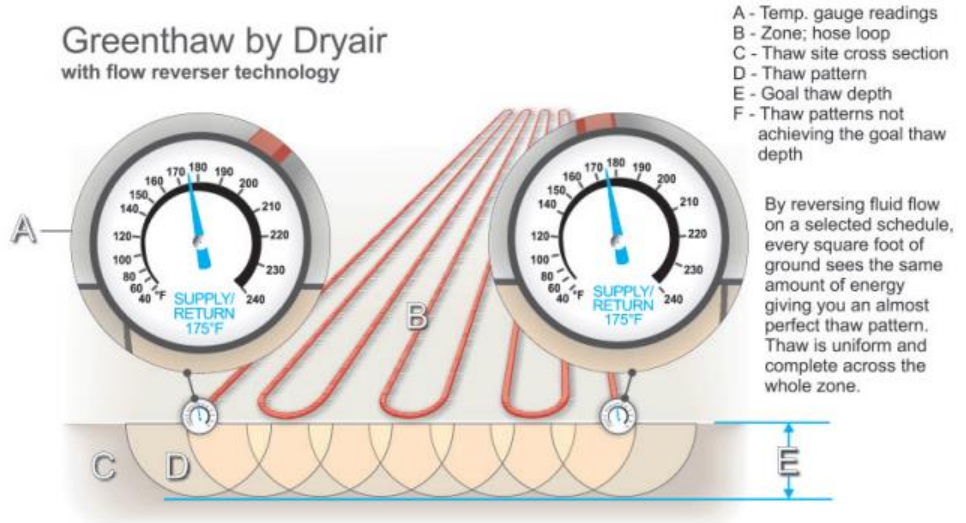

Figure 12 - Flow Reverser Technology, Even Thaw Pattern

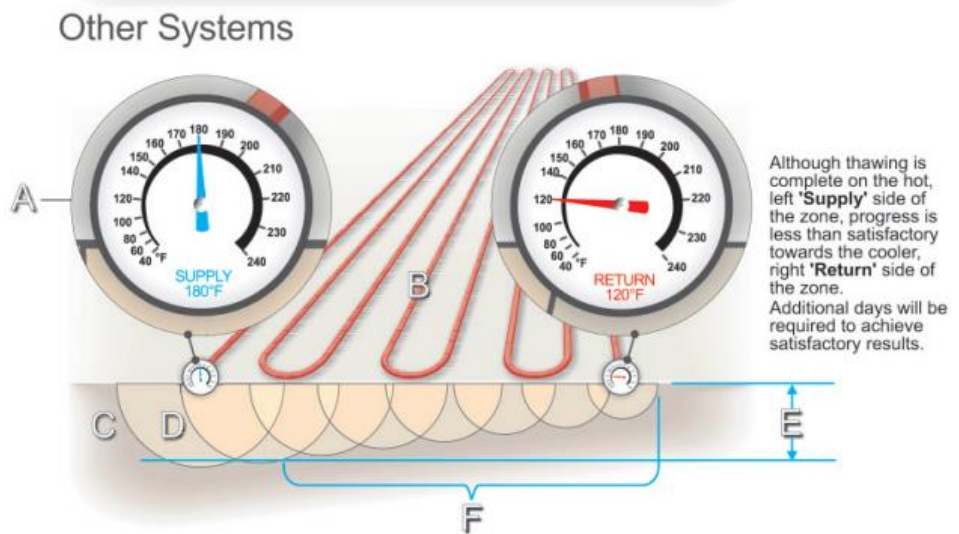

Figure 13 - Without Flow Reverser Technology, Uneven Thaw Pattern

4. Setup

The positioning of all the system components on the site will be influenced by several factors. Please read the entire “Setup” section before beginning. Be sure to observe all local electrical codes and fire regulations when positioning the central heating module.

Lifting the Unit

Prerequisites

- Properly rated lifting equipment (crane or hoist). A fully loaded model 200 GTS can weigh in excess of 6,000lbs (2,720kgs).
- Inspect lift components for damage and defects. If any of the components are damaged or have defects, replace affected components before proceeding.
- Attach “017-904702 SLING 4X7’ 10,300 LB @ 60 DEGREES” lift sling.
- Ensure unit is off and all electrical power and HTF circulation lines are disconnected.
- All doors and access covers are closed and secured.

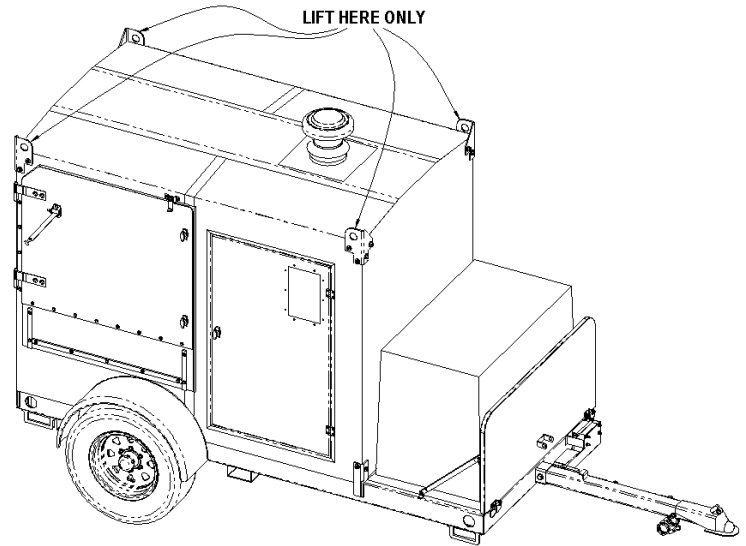

Figure 14 - Lifting Points

Warning! Crushing hazard. You may be crushed if the lifting devices fail.

- Never stand under or get onto the machine while it is being lifted or moved.
- Use only designated lift points to lift the machine.

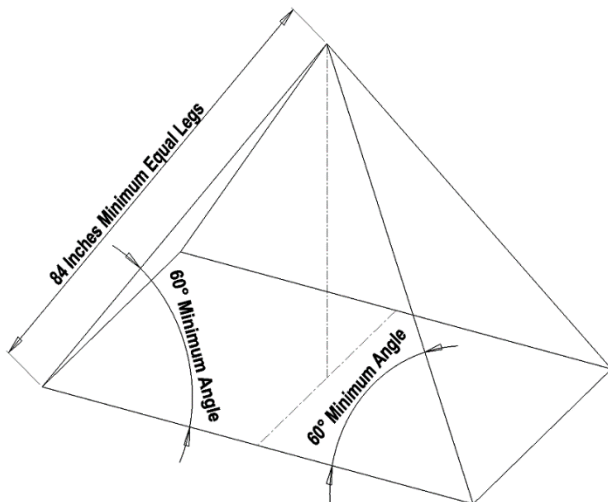

Figure 16 - Lifting Sling Angles



Figure 15 - Sling 4x7' (Part# 017-904702)

Tie-Down

Using proper tie-down points will allow for safe and easy transport of your unit.

Prerequisites

- Properly rated chains or straps. A fully loaded model 200 GTS can weigh in excess of 6,000lbs (2,720kgs).
- All doors and access covers closed and secured.

Note: Use only approved tie-down points.

1. After loading the unit onto a deck deploy the jack. With the assistance of the jack, position substantial blocking under the front most crossmember of the trailer so that the unit is slightly lower front to back. Remove tension from the jack to ensure the jack is not damaged by compressing resulting from tightening chains or straps.
2. Using the rear most tie-down points, through both eyes, strap or chain the unit at a rearward angle. Initially apply only enough tension to keep the unit from rolling
3. Using the front tie down points (through both eyes) strap or chain the unit, at a forward angle providing both downward pressure on the blocking and slight forward pressure
4. Alternately tighten rear straps or chains as required to secure the unit for transport.
5. Check chain or strap tension after the first 30 mi (50 km) of travel and every 100 miles (160km) thereafter.

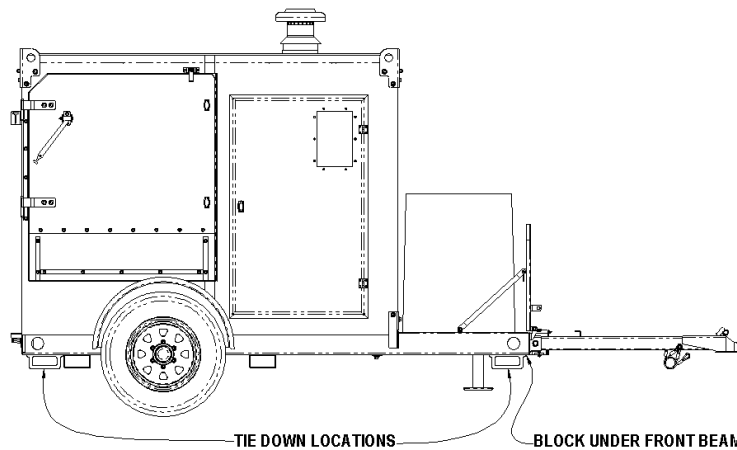

Figure 17 - Tie-Down Points

Required Safety Clearances

The 200 GTS is a heating appliance, therefore safe heat and exhaust clearances must be observed from combustible materials and for service access.

- Maintain 24" (61 cm) of clearance on all sides of the unit (*Figure 18*).
- Maintain 36" (91 cm) of clearance on all sides of the flue pipe and chimney cap (*Figure 19*).

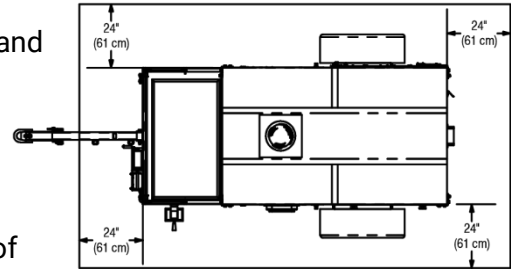

Figure 18 - Top-View Clearances

Elevation Concerns

Do not place any "portable heat exchangers" or "circulation line heat exchangers" higher than the top of the integral heat transfer fluid tank without using a reservoir extension kit (*Figure 6*). If this is not observed, the following can occur:

- **Insufficient Fluid in the System**
Fluid will drain back to the heat transfer fill tank from the over-elevated fluid lines when the pump is shut off. The heat transfer fill tank will show adequate fluid but, when the pump is started, extra fluid will be required to recharge the over-elevated fluid lines and portable heat exchangers and the system will then have insufficient fluid in the reservoir.
- **Fluid Overflow**
If fluid is added to maintain proper fluid levels while the pump is running, overflow at the fill tank may occur when the pump is shut off. This would occur because of drain back from the over-elevated fluid lines.

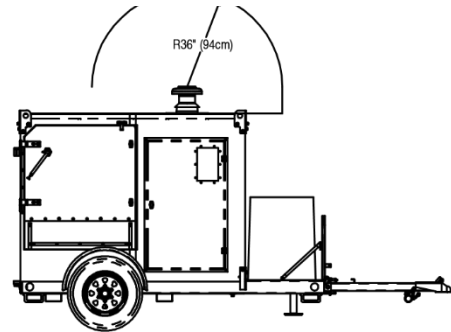

Figure 19 - Side-View Clearance

Electrical Requirements & Connection

When determining the central mobile enclosure's location on site, consider proximity to the electrical power supply.

Note: This applies mainly to systems not equipped with a dedicated generator.

- The 200 GTS's main feed wiring must be adequately sized to carry the minimum ampacity shown on the water heater cabinet's rating label. All electrical connections, connectors and wire must be CSA/UL compliant and installed according to local laws and codes.
- Before making any electrical connections, be sure that the power supply is "Off".

200 GTS Electrical Connection

- The 200 GTS can be run on 120V AC.
- 120V AC power can be supplied to either the water heater circuit or the hose reel circuit, or both. This gives the operator the flexibility to use common household electrical connections on the unit.
- If intending to run the water heater and the hose reel simultaneously on 120V AC power, the unit must be fed from isolated circuits.
- The 120V AC power is input through standard NEMA 5-15 plugs.
- The main feed wiring must be adequately sized to carry the minimum ampacity shown on the central heat module's rating label.
- All electrical connections, connectors and wire must be CSA/UL approved, and installed according to local laws and codes.



Figure 20 - Power Connections

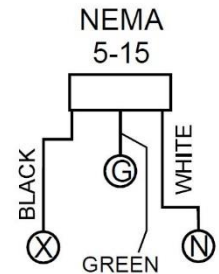

Figure 21 - NEMA 5-15 Wiring

Note: Warranty is void if the wiring hookup is not done correctly.

Heat Transfer Fluid (HTF)

CAUTION! At no time should you use automobile antifreeze in your system. The use of automobile antifreeze will void your warranty.

- Heat Transfer Fluid circuit has an on-board "open-vented" glycol reservoir.
- The heat transfer fluid "HTF" level should show no more than $\frac{1}{4}$ on the gauge (cold fluid) at start-up. As the "HTF" warms to operating temperature, fluid expansion will raise the level to $\frac{1}{2}$ or $\frac{3}{4}$ on the gauge (depending on the total volume of fluid in the circulation system).

HTF Specifications

- DRYAIR pre-mixed “HTF” fluid is made up of 50% “Dowfrost ® HTF” or “Boss Chill PG” and 50% water, by weight - freeze protection down to -28°F (-33°C).
- The “glycol/water mixture chart” will provide you with more information on the proper mixture for your area (*Figure 22*).
- Soft water with a neutral pH level (#7) must be used.

Percent Propylene Glycol		Freezing Point	
By Mass	By Volume	°F	°C
0.0	0.0	32.0	0.0
10.0	9.6	26.1	-3.2
20.0	19.4	17.9	-7.8
30.0	29.4	6.7	-14.0
40.0	39.6	-8.1	-22.3
50.0	49.9	-28.9	-33.8
60.0	60.0	-54.9	-48.3

Figure 22 - Glycol Mixing Guide

CAUTION! Whenever coupling or uncoupling quick couplers, make sure that the isolation valves are closed, and the pump is off. Failure to do so may put you at risk of injury from eye and/or skin exposure to hot glycol.

Fuel

- Only clean #1 or #2 diesel fuel or light heating oil is suitable for use in the system. *
- The “central heating module” comes equipped with its own tank, so there are no fuel line hookups required.
- The fuel system utilizes a two-pipe system to ensure efficient fuel supply to the burner.

* Contact your local fuel supplier to inform them of the requirements.

Primary “HTF” Circulation Lines

- If possible, position the primary circulation lines out of high traffic areas.
- Quick couplers are attached to both ends of the primary circulation lines (ground heating hoses) to enable quick coupling. This also allows the isolation of the primary lines while retaining the heat transfer fluid “HTF” in the lines. Quick couplers also make setup and dismantling of the circulation system much quicker.

If using other heat transfer accessories, it may be necessary to connect to the Camlock couplers located inside the unit near the control panel. Note that for space heating and fluid heating applications it is advisable that the flow reverser be set to "Off".

- Connect the primary circulation lines to the "supply" and "return" Camlock couplers on the unit (Figure 23). Isolation valves and Camlock couplers are attached at both ends of the primary circulation lines to enable quick coupling. This also allows the isolation of the primary lines while retaining the heat transfer fluid (HTF) in the lines.



Figure 23 - Camlock Couplers

Burner Removal

To remove an existing **Riello Model 40-F5 Diesel/Light Oil Burner**:

1. Make certain that the power supply to the central heat module is disconnected.
2. Disconnect the electrical connections to the burner (Figure 24). Slip the strain relief connection (Figure 24) from the burner chassis, located in the bottom right corner of the burner assembly.
3. Disconnect the fuel supply hose (Figure 25) and fuel return hose (Figure 25) by unscrewing the fuel line connections on the side of the burner. The loose supply and return hose ends should be plugged and pushed aside, out of the way, inside the cabinet. Mark hoses for correct reconnection.
4. Remove 2 nuts (Figure 26) from top of burner tube bracket.
5. Pull burner toward you and away from the mounting bracket (Figure 26).

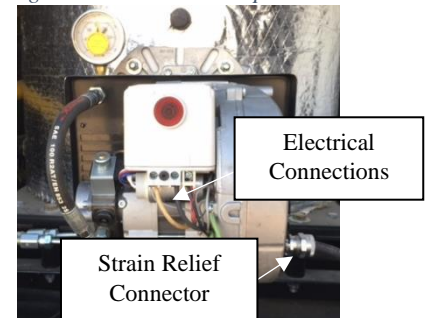

Figure 24 - Riello Burner Front

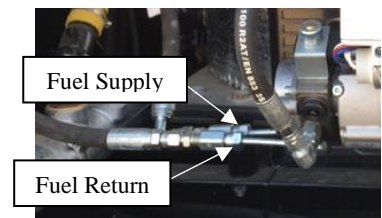

Figure 25 - Riello Burner Side (Fuel Lines)

Burner Installation

To install a **Riello Model 40-F5 Diesel/Light Oil Burner**:

1. Insert burner into the mounting bracket (Figure 26).
2. Install 2 nuts (Figure 26) at top of burner tube bracket.
3. Connect the fuel supply hose (Figure 25) and fuel return hose (Figure 25) by coupling them to the JIC connections on the side of the burner. Ensure hoses are attached to correct connectors.
4. Slip the strain relief connection (Figure 24) into the burner chassis, located in the bottom right corner of the burner assembly. Connect the electrical connections (Figure 24) to the burner.

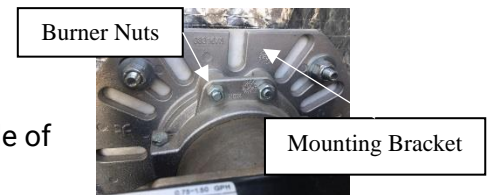

Figure 26 - Riello Burner Top

5. Operation

Purging Air from the "HTF" Circulation System

- Verify that the heat transfer fluid level is in the lower half of the "Normal" range (Figure 27).
- Complete the connection for one 600 or 1,200 foot "heat exchanger loop" or "portable heat exchanger" (Figure 28). This will complete the circulation loop and allow circulation.
- Toggle the pump switch to the "On" (up) position and run the pump (Figure 29). This will release the air from the system.
- Air is vented directly through the onboard expansion/reservoir tank.
- Monitor the "heat transfer fluid sight glass" and make sure that the heat transfer fluid level stays in the "Normal" range throughout this entire process.
 Note that there may be a certain amount of air in the system. "HTF" levels may change as air is displaced from the system. Add "HTF" to maintain level in the lower half of the "Normal" range when the fluid is cold. Observe the sight glass on the outside of the unit.

When the air is eliminated, the "System Pressure" gauge will hold at a steady reading of between 10 to 40 PSI (Figure 30).



Figure 27 - HTF Level Indicator



Figure 28 - Circulation Manifold



Figure 29 - Control Panel Switches

Before Firing the System

- Verify that the power supply is correct and that the electrical hook up is as specified in "Setup" (4-1).
- Verify that the water heater is being supplied with the same fuel type as indicated on the water heater data plate.
- Verify that the heat transfer fluid level gauge shows within the "Normal" range.
- Verify air intake vent is fully open (Figure 32).
- Verify fuel shutoff valve is open (handle in line with flow) (Figure 31).



Figure 32 - Air Intake Vent



Figure 30 - System Pressure Gauge



Figure 31 - Fuel Shutoff Valve (Closed)

Temperate Start Procedure

You can proceed with this procedure when:

- a) The ambient outdoor air temperature is above 23° F (-5° C) or
- b) The recommended "cold start procedure" has been completed if below 23° F (-5° C).

Initiate Firing

- Verify that the pump switch is in the "On" (up) position (*Figure 33*).
- Toggle the water heater switch to the "On" (up) position.
- The burner will proceed through its firing sequence.
- Once the burner is operating smoothly and the system pressure is steady (air has been eliminated from the system), monitor the "supply temperature". Supply temperature should be rising (*Figure 34*).
- Verify that only one "circulation line heat exchanger loop" or one "portable heat exchanger" is connected to the primary lines through the distribution manifold.
- Monitor the "Return Temperature" gauge (*Figure 34*).
- Before fully connecting more "circulation line heat exchanger loops" or "portable heat exchangers", this gauge must show a noticeable rise in temperature indicating the heat transfer fluid has made a full circuit. With "circulation line heat exchanger loops", this may take 20 minutes or more.
- Repeat the previous step until all "portable heat exchangers" or "heat exchanger loops" are connected and circulating.



Figure 33 - Control Panel Switches



Figure 34 - Control Panel Gauges

Cold Start Procedure

This is recommended if the ambient outdoor air temperature is lower than 23° F (-5° C).

For optimal starting, heat exchanger life, and to minimize sooting, consider initiating this process well in advance of firing the system. The required preheat time is dependant on the outdoor ambient temperature. The colder it is, the greater length of time preheating will take. Consideration must also be given to the temperatures in the previous 12 hours leading up to intended start time.

- The system has a built-in, electric "cold start" fluid pre-heater which will heat the "heat transfer fluid" in the water heater heat exchanger as well as a built-in nozzle heater to assist in initial burner firing.
- Verify that the pump switch and water heater switch are in the "Off" (down) position (*Figure 33; 5-2*).
- Verify that the unit is connected to power supply, "Power 110V" light will be on (*Figure 34; 5-2*).
- This will automatically energize the electric "cold start" circulation heater and nozzle heater.
- Preheat unit until the Supply Temperature Gauge (*Figure 34; 5-2*) reads between 60° F to 80° F (60° C to 65° C).
- The time required for the heat transfer fluid in the heat exchanger to reach this temperature will depend on the outdoor ambient air temperature.

- Toggle the pump switch (*Figure 33; 5-2*) located on the control panel to the "On" (up) position. Once the pump is turned on, the "cold start" fluid preheater and nozzle heater are automatically shut off. If pump fails to start or overloads circuit breaker, see "***Extreme cold start procedure***".
- With the pump on, the HTF will circulate through the heat module's internal bypass system. This will supply warm HTF to the combustion air and fuel preheat systems, which tempers combustion air and fuel for smooth burner start-up and operation.
- Circulate the HTF within the heat module's distribution system approximately 3 minutes.
- The burner is now ready to be fired. Proceed with the "Temperate Start Procedure".

Note: *If start up is required sooner (unplanned) a short 5 minute preheat cycle can be tried. If using a 5 minute preheat cycle, rough running can be expected for the first few minutes of operation.*

Extreme Cold Start Procedure

Note: In extreme cold 0° F (-18° C), the HTF becomes very viscous (resistant to flow) and can cause overloading of the pump causing circuit breakers to trip. In extreme cold conditions, closing the pump isolation valve (*Figure 35*) on the supply side of the pump reduces the pump load allowing the pump to start without overloading the electrical circuit. Once the pump is running, the pump isolation valve can be gradually opened to the fully open position allowing normal operation.

Note: *This procedure will not harm the pump. In extreme cold, pump seal leakage is normal and will subside once HTF temperature rises.*



Figure 35 - Pump Isolation Valve

Adding "HTF" to System

Verify that the power supply is correct, and that the electrical hook-up is as specified in "Setup" (4-1).

- Connect the fill/drain hose (Figure 36) to the coupler located on the intake side of the pump (Figure 37).
- Submerge the fill/drain hose into the bottom of the barrel/pail or jug of pre-mixed "HTF" (See "Setup" for heat transfer fluid specifications).
- Turn the pump isolation valve to the "Closed" position. (Perpendicular to flow-through pipe) (Figure 37).
- Turn the fill/drain ball valve to the "Open" position (Figure 37).
- Toggle the pump switch to the "On" (up) position.
- Once the pump switch is in the "On" position, the pump will begin drawing the "HTF" into the system. While watching the glycol level gauge continue to fill the system until the glycol level is in the middle of the "Normal" range.

Note: Caution must be taken when approaching the middle of the "Normal" range as it could take 2-3 seconds to register the actual level once pumping has ceased.

In the case of an overfull situation, do the following:

- Toggle the pump switch to the "Off" (down) position.
- Verify that the fill/drain ball valve is in the "Open" position (Figure 37).
- Turn the pump isolation valve to the "Open" position (Figure 37).
- Gravity will immediately drain the glycol out of the system through the fill/drain hose. The fill/drain hose should be submerged into a barrel/pail or jug with sufficient room for the "HTF". Once the desired amount of "HTF" has been attained and the glycol level is in the middle of the "Normal" range, turn the pump isolation valve to the "closed" position and continue with the following procedures (Figure 37).
- Turn the fill/drain ball valve to the "Closed" position (Figure 37).
- Uncouple the fill/drain hose from the pump.



Figure 36 - Fill/Drain Hose

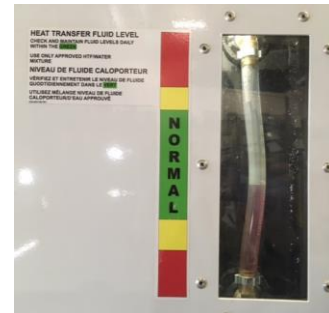
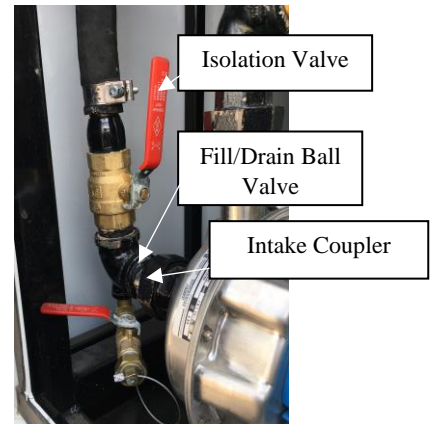

Figure 38 - HTF Level Indicator

Purging Air from the Fuel System

If the burner does not fire, the burner control will “lock out”. If the burner is in “lock out” the burner reset button will be illuminated red (*Figure 39*). The fuel system may have to be purged of air.

- Confirm that there is an adequate fuel supply.
- Confirm that the pump switch is in the "On" (up) position.
- Confirm that the water heater switch in the "On" (up) position.
- Depress the reset button on the burner. This will activate the fuel pump & burner firing sequence.

When the fuel system is primed, the fuel pressure gauge on the burner will show a steady reading and the water heater should attempt to ignite.

Note: *The reset process can be tried up to six times, at the most. If the water heater does not fire, see the accompanying “Water Heater Module - Service Manual” or “Riello Burner Installation Manual” for information and/or contact DRYAIR Technical Support 1 (888) 750-1700.*



Figure 39 - Burner Reset Button

6. Hose Reel

DANGER! It is very important that you read and understand this section before operating the hose reel. Failure to follow the procedures and cautions in this manual could lead to injury or possible death.

The DRYAIR hose reel's primary purpose is to dispense and collect fluid circulation hose on job sites, primarily with respect to ground thaw and/or concrete cure operations.

The hose reel includes the following controls:

- Spool directional controls
- Momentary foot switch for load or unload application
- Hose reel drive speed
- Degree of drive engagement/braking

Unloading

- To unload the hose reel disengage the drive by pulling the clutch lever out (Figure 42). This allows the reel to turn freely for hose removal.
- Pull required amount of hose from the hose reel.
- Adjust the hose reel brake as desired to prevent the hose reel from "free-wheeling" causing unwanted off-loading of hose caused by gravity/inertia (Figure 41).
- Engage the drive by pushing the clutch lever in to prevent the hose reel from rotating (Figure 43; 6-1).

Loading

- The hose reel is powered through a power receptacle on the front of the unit (Figure 20; 4-4)
- The motor is protected by a "push to reset" circuit breaker located on the control panel (Figure 34; 5-2).
- The user is protected by a GFCI switch located on the hose reel (Figure 44).
- Verify that the hose reel is connected to a 120 VAC power source (Figure 20; 4-4).



Figure 40 - Hose Reel



Figure 41 - Hose Reel Brake



Figure 42 - Clutch Lever Out



Figure 43 - Clutch Lever In



Figure 44 - GFCI Switch

- Verify that the circuit breaker located on the control panel is reset (pushed in) (Figure 34; 5-2).
- Verify that the GFCI is reset (Figure 44).
- Verify that the clutch lever is pushed in to engage drive (Figure 43).
- To load the hose reel, move the foot-operated switch to a convenient location that will allow full access to guide the hose neatly onto the reel. Depress the foot switch to activate the hose reel motor (Figure 45).
- Guide the hose onto the reel in uniform layers to ensure the hose remains kink-free allowing fluid to flow through (Figure 46).
- When the hose is loaded onto the reel disconnect the reel from power and stow the foot switch under the hose reel (Figure 46).



Figure 45 - Foot Switch



Figure 46 - Stowed Foot Switch

Secondary Fluid Containment

- Drain secondary fluid containment as required.
- Two drain plugs are provided in the front corners for convenience (Figure 47).



Figure 47 - Secondary Fluid Containment Drain Plug

Shut-Down Procedure

- Toggle the water heater (burner) switch to the “Off” position (Figure 33; 5-2).
- Allow supply temperature to cool down to approximately 100 degrees F.
- Toggle pump switch to the “Off” position (Figure 33; 5-2).
- Close fuel shutoff valve (Figure 31; 5-1).
- Disconnect power from unit.

Note: Always keep the fuel valve supply shut off if the burner is shut down for an extended period of time.



Figure 48 - Fuel Shutoff Valve (Closed)

Transportation

- Verify that the power has been disconnected.
- Verify that all circulation lines have been disconnected and properly stowed.
- Verify that the hose reel clutch lever has been pushed in (*Figure 43; 6-1*) to prevent hose reel turning freely.
- Verify that the air intake vent is fully closed (*Figure 32; 5-1*).
- Verify that all doors have been securely latched and locked (recommended).
- Verify that the hose reel door safety latch is free and in the latched position (*Figure 49*).
- See "Trailer Safety" 2-3 for towing



Figure 49 - Hose Reel Door Safety Latch

7. Troubleshooting

Troubleshooting (CME)

- There are 6 green lights on the top and 2 red lights on the bottom of the control panel, which indicate the status of a sequence of functions while the unit is running.
- When the burner is on, all green lights should be on. With the burner on, any of the six green lights which is not on should be considered burned out.
- Aquastat and burner light go off and on as the burner cycles.
- Pump and Burner switches in the ON position for troubleshooting.
- The terminal strips, located behind the control panel, must be accessed to initiate troubleshooting procedures.
- Use electrical schematic decal assist in locating components.



No Power

Check for 120V AC power between letter N and H on the terminal strip. If there is no power, check the following:

- a) Check that the water heater circuit breaker has been reset (pushed in).
- b) Check for power in and out of the circuit breaker.
- c) Check that correct power supply has been connected to the unit. Investigate power source and be certain that the power characteristics are correct. (120V AC, 15 A, single phase, 3-conductor, 0'-100' - 12 AWG, over 100' - 10 AWG)



No Power at Terminal#6 (Low Water Cut-Off)

Check for 120V AC power between letter N and #6 on the terminal strip. If there is no power, check the following:

- a) Low water situation. Check fluid level in tank and add if necessary.
- b) Low fuel situation. Check fuel level in tank and add if necessary.
- c) 24V AC power. Check that the 24V circuit breaker has been reset (pushed in). Check for 24V AC power between #1 and #3 on the terminal strip. Replace transformer if 24V AC is not present.
- d) Ensure pump is running. If not, turn burner switch off and recheck for pump operation. If pump is running with burner switch off but stops running when burner is switched on, the lower float switch in glycol tank or circuit is faulty.
- e) If pump is running with burner switched on, check for 120V AC power on right-hand C and N/O contacts of relay #1. If power is present on only 1 contact, replace relay #1 (120V). If power is present on both contacts, check for 120V AC power on right-hand C and N/O contacts on relay #4. If power is present on only 1 contact, replace relay #4 (24V).
- f) If pump is not running with burner switch off, check for 120V AC power on both terminals of the pump switch. If power is present on only 1 terminal, replace the switch. If power is present on both terminals, check for 120V AC power on left-hand C and N/C contacts of relay #3. If power is present on only 1 contact, replace relay #3 (24V). If power is present on both contacts, check for 120V AC power on left-hand C and N/O contacts of relay #1. If power is present on only 1 contact, replace relay #1 (120V). If power is present on both contacts, check for 120V AC power on left-hand C and N/O of relay #4. If power is present on only 1 contact, replace relay #4 (24V). If power is present on both contacts, replace pump.



No Power at Terminal #7 (Flow Switch)

Check for 120V AC power between letter N and #7 on the terminal strip. If there is no power, check the following:

a) Pump not running. Check for 120V AC power on both terminals of the pump switch. If power is present on only 1 terminal, replace the switch. If power is present on both terminals, check for 120V AC power on left-hand C and N/C contacts of relay #3. If power is present on only 1 contact replace relay #3 (24V). If power is present on both contacts, check for 120V AC power on left-hand C and N/O contacts of relay #1. If power is present on only 1 contact, replace relay #1 (120V.) If power is present on both contacts, check for 120V AC power on left-hand C and N/O of relay #4. If power is present on only 1 contact, replace relay #4 (24V). If power is present on both contacts, replace pump.

b) Inadequate flow.

- Check that at least 1 heat exchanger or hose loop is connected allowing flow.
- Check that all valves are open in the fluid-circulation loop.
- Check that hose quick couplers are fully seated and allowing flow.
- Check that pressure bypass valve is open if fluid-receiving units are closed off.
- Air present in the circulation system. Air in the system can cause cavitation in the pump and pressure loss. Refer to "Operation, Purging air from the system" for air purging instructions.
- Supply temperature overrun causing vaporization (steam) & pump pressure to be lost. Cavitation will occur in the "water heater heat exchanger" causing a noticeable bubbling, popping sound. Check the "overflow outlet" to confirm presence of fluid vapor. If vaporization is occurring, the "Aquastat" setting is set too high. Reset the "Aquastat" to a lower temperature (10°F increments) and allow cool-down. When the "heat transfer fluid" cools down, the system will regain pump pressure. Allow the burner to cycle back on and observe to ensure that the vaporization situation does not reoccur. If it does reoccur, reset the "Aquastat" to a lower temperature until the problem is rectified.

Note: This situation will occur most often in a "low flow and/or low heat requirement" situation.

c) Defective flow switch. If a) and b) check out, the flow switch will need to be recalibrated or replaced.



No Power at Terminal #8 (High Limit).

Check for 120V AC power between letter N and #8 on the terminal strip. If there is no power, check the following:

- a) Check control settings. The automatic reset high limit should be set 10°F higher than the set point of the aquastat.
- b) With control setting 10°F above aquastat setting and above current supply temperature, check for 120V AC power on both terminals of high limit control. If power is present on only 1 terminal, replace high limit control.

No Power at Terminal #9 (Aquastat and Burner)



Check for 120V AC power between letter N and #9 on the terminal strip. If there is no power, check the following:

- a) Check that aquastat set point is above current supply temperature.
- b) Check aquastat sensor and verify that it is positioned properly in its well.
- c) If a) and b) check out, replace both aquastat and well sensor.

FOR ADDITIONAL ASSISTANT CALL DRYAIR TECHNICAL SUPPORT 1 (888) 750-1700

Troubleshooting Hose Reel

- The hose reel is powered through a power receptacle on the front of the unit (*Figure 20; 4-4*).
- The motor is protected by a “push to reset” circuit breaker located on the control panel (*Figure 34; 5-2*).
- The user is protected by a GFCI switch located on the hose reel (*Figure 44; 6-1*).
- Verify that the hose reel is connected to a 120V AC power source (*Figure 20; 4-4*).
- Verify that the circuit breaker located on the control panel is reset (pushed in) (*Figure 34; 5-2*).
- Verify that the GFCI is reset (*Figure 44; 6-1*).

FOR ADDITIONAL ASSISTANCE CALL DRYAIR TECHNICAL SUPPORT 1 (888) 750-1700

8. Maintenance

The DRYAIR system is designed to be a low maintenance system. All system equipment is assembled using extensively tested and certified components. Following these maintenance procedures will ensure the maximum benefit and minimal downtime for the system. The daily maintenance schedule is designed to be a quick system check and ensures a low risk of operating interruptions. Additional supplemental information provided by component manufactures such as the hose reel and is included with each unit. Use the supplemental information for maintenance procedures and frequency as directed.

Daily Checklist

A daily inspection of the water heater cabinet should be performed with attention paid to the following:

Check for Strong Odor of Fuel

- If a leak or the odor of fuel is noticed, immediately turn off all power switches and the main fuel supply to the water heater cabinet.
- Ventilate the water heater cabinet.
- Find and correct the leak before turning on any power or trying to relight the water heater.

Check Heat Transfer Fluid "HTF" Level Everyday

- Maintain HTF level in the upper half of the "Normal" range when fluid is hot.
- Top up as necessary.
- For "HTF" specifications, see "Setup, Heat Transfer Fluid "HTF", Fluid Specifications.
- For "HTF" handling precautions, refer to the "Safety Concerns, Material Safety Data Sheet".
- If loss of fluid is excessive, check for leaks at all fittings and connections in the water heater cabinet as well as the fluid circulation system.

Check the Supply Temperature Gauge

- Verify that the supply temperature gauge is within 10°F of the Aquastat setting.

Seasonal Checklist

Fuel (Water Block / Particulate) Filter

- The water block/particulate filter should be changed every heating season or as required.

Hoses

- Periodically check all hoses for damage due to aging, elevated temperatures, over-torqued hose clamps, abrasion and weathering.
- Replace damaged hoses as required.
- Seasonally check hose clamp torque and adjust accordingly.

Water Heater Heat Exchanger

- Keep the flues in the water heater clean. Because soot is a non-conductor of heat, a dirty water heater requires more fuel to heat a structure than a clean one. Water heaters can corrode on the fireside. This results from corrosive substances in the fuel and can be difficult to control. Some fuel oils contain substances, which cause fireside corrosion. Sulphur, vanadium and sodium are among the materials that may contribute to this problem. The probability of trouble from this source depends to a large degree on the amount of Sulphur in the fuel and on the care used in cleaning the fireside heating surfaces. This is particularly true when preparing a boiler for a period of idleness. Preventing this problem also depends on keeping the boiler heating surfaces dry when a boiler is out of service.
- The person responsible for water heater maintenance should be certain that the fireside surfaces of the water heaters in his care are thoroughly cleaned at the end of the firing season. He should also observe the fireside surfaces during the firing season and if signs of corrosion are discovered, a reputable consultant should be contacted.
- The flue pipe and chimney cap should be taken off once a year and thoroughly cleaned of all soot.

Note: Check the gauge panel at regular intervals for any irregular gauge readings.

Heat Transfer Fluid “HTF”

- A clean, properly maintained hot water system should not be drained unless: there is possibility of freezing, the water heater has accumulated a considerable amount of sludge or dirt on the water side, or draining is necessary to permit repairs. Very little sludge should accumulate in a water heater where little make-up water is added and where an appropriate water heater water treatment is maintained at proper strength.
- The HTF should be tested from year to year for freeze protection and should be strong enough for your area. The HTF should be checked with a refractometer. Check the glycol/water mixture chart (see *Setup: Heat Transfer Fluid (HTF); 4-4*) for mixing ratios.
- The pH level of the heat transfer fluid requires an annual check to see if the pH level is neutral. The pH level should be at #7. This should be checked with a pH instrument.

Note: See *Setup: Heat Transfer Fluid (HTF), Heat Transfer Fluid Specifications (4-4)* for complete HTF specifications.

Burner

- For burner seasonal maintenance, see the "Service Manual".

Hose Reel

- For seasonal maintenance, see the “Supplemental information” provided by the manufacturer.

9. Appendix

Important Certification & Operational Information Decals

Non-Pressure Vessel Decal

- The unit includes an open atmospherically vented expansion tank
- The expansion tank is integrally connected to the heat-exchanger section of the water heater by means of a permanently open line (no valves).
- The heat exchange section connects to the inlet side of the circulating pump and therefore, only neutral atmospheric pressure is present within the heat exchange section.

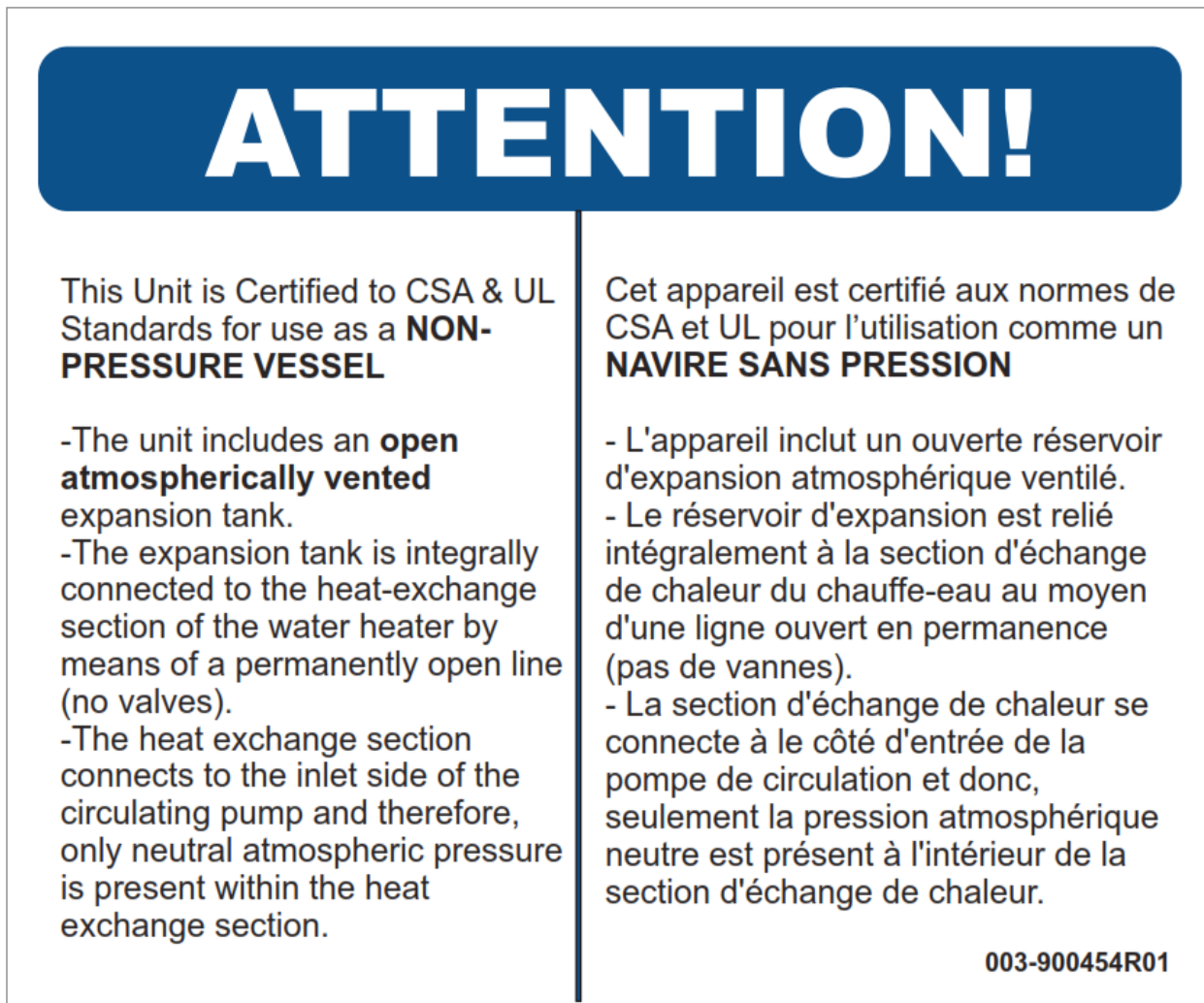

ATTENTION!

This Unit is Certified to CSA & UL Standards for use as a **NON-PRESSURE VESSEL**

- The unit includes an **open atmospherically vented** expansion tank.
- The expansion tank is integrally connected to the heat-exchange section of the water heater by means of a permanently open line (no valves).
- The heat exchange section connects to the inlet side of the circulating pump and therefore, only neutral atmospheric pressure is present within the heat exchange section.



Cet appareil est certifié aux normes de CSA et UL pour l'utilisation comme un **NAVIRE SANS PRESSION**

- L'appareil inclut un ouverte réservoir d'expansion atmosphérique ventilé.
- Le réservoir d'expansion est relié intégralement à la section d'échange de chaleur du chauffe-eau au moyen d'une ligne ouvert en permanence (pas de vannes).
- La section d'échange de chaleur se connecte à le côté d'entrée de la pompe de circulation et donc, seulement la pression atmosphérique neutre est présent à l'intérieur de la section d'échange de chaleur.

003-900454R01

Figure 50 - Non-Pressure Vessel Decal

Certification & Heater Specifications

		P.O Box 126 400 Service Road St. Brieux, SK Canada S0K 3V0		 MADE IN CANADA
		DRYAIR Model:	200-GTS	Reference:
Serial No.:		Prod. Sched.:		

Main Power		Oil Burner		
Volts:	120 V	Model:	Riello 40-F5	
Phase:	1	Fuel:	#2 Heating Oil	#1 Heating Oil
Hz:	60 HZ	Calorific Value:	140,000 BTU / US Gal.	136,000 BTU / US Gal.
Max. Ampacity	15A	Output:	183,008 BTUH	177,780 BTUH
Control Voltage	120/24VAC	Fuel Input:	1.52	US GPH
		Pump Pressure:	160	P.S.I.

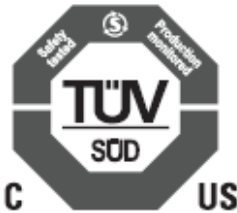

Clearances:	
Sides	24" (61cm) minimum
Flue Pipe	36" (91cm) minimum
Floor	0" (0cm) non-combustible

003-904682

Figure 51 - Water Heater Data & Serial Plate

Electrical Schematics

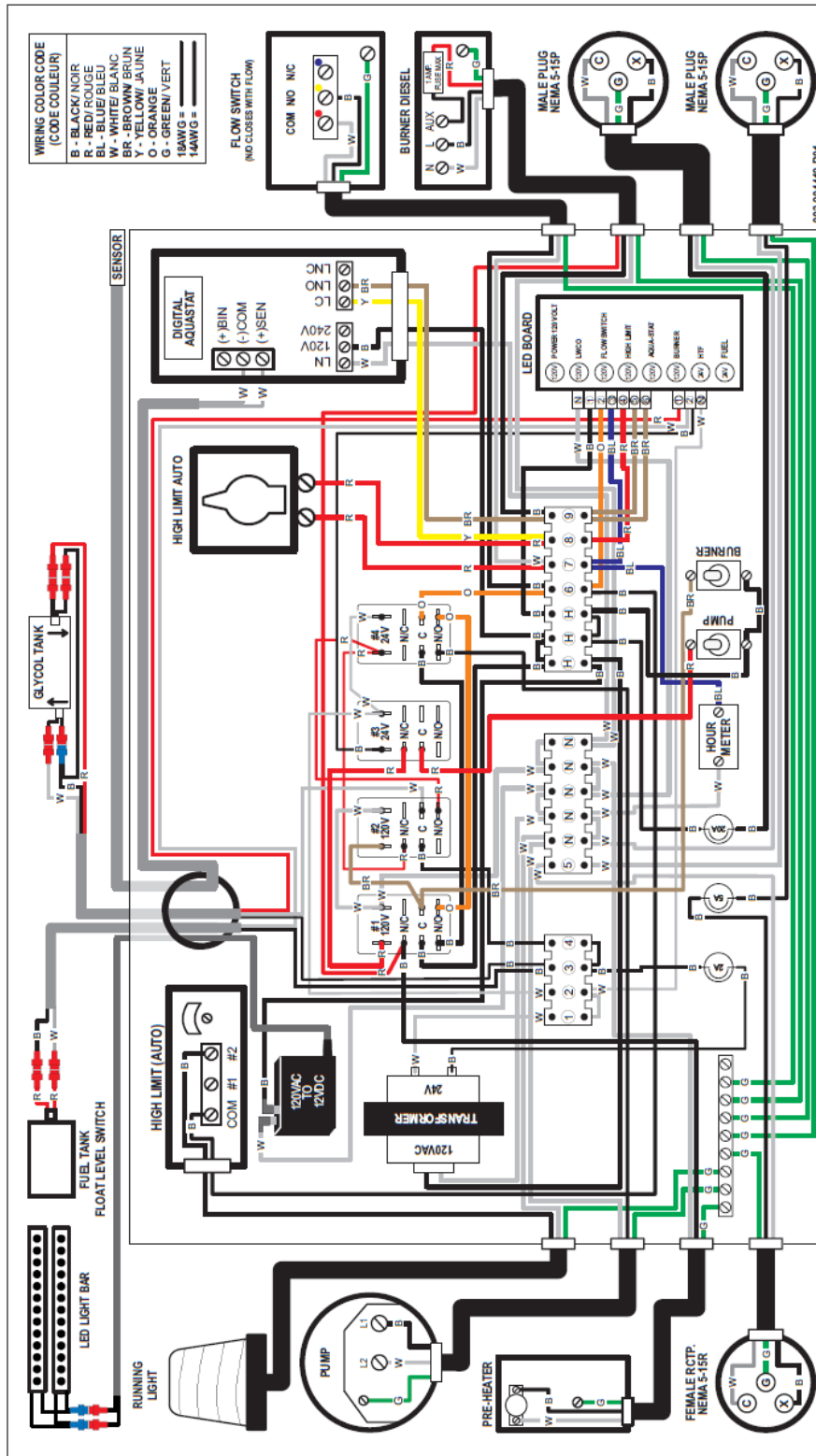

Figure 52 - 200 GTS Electrical Schematic

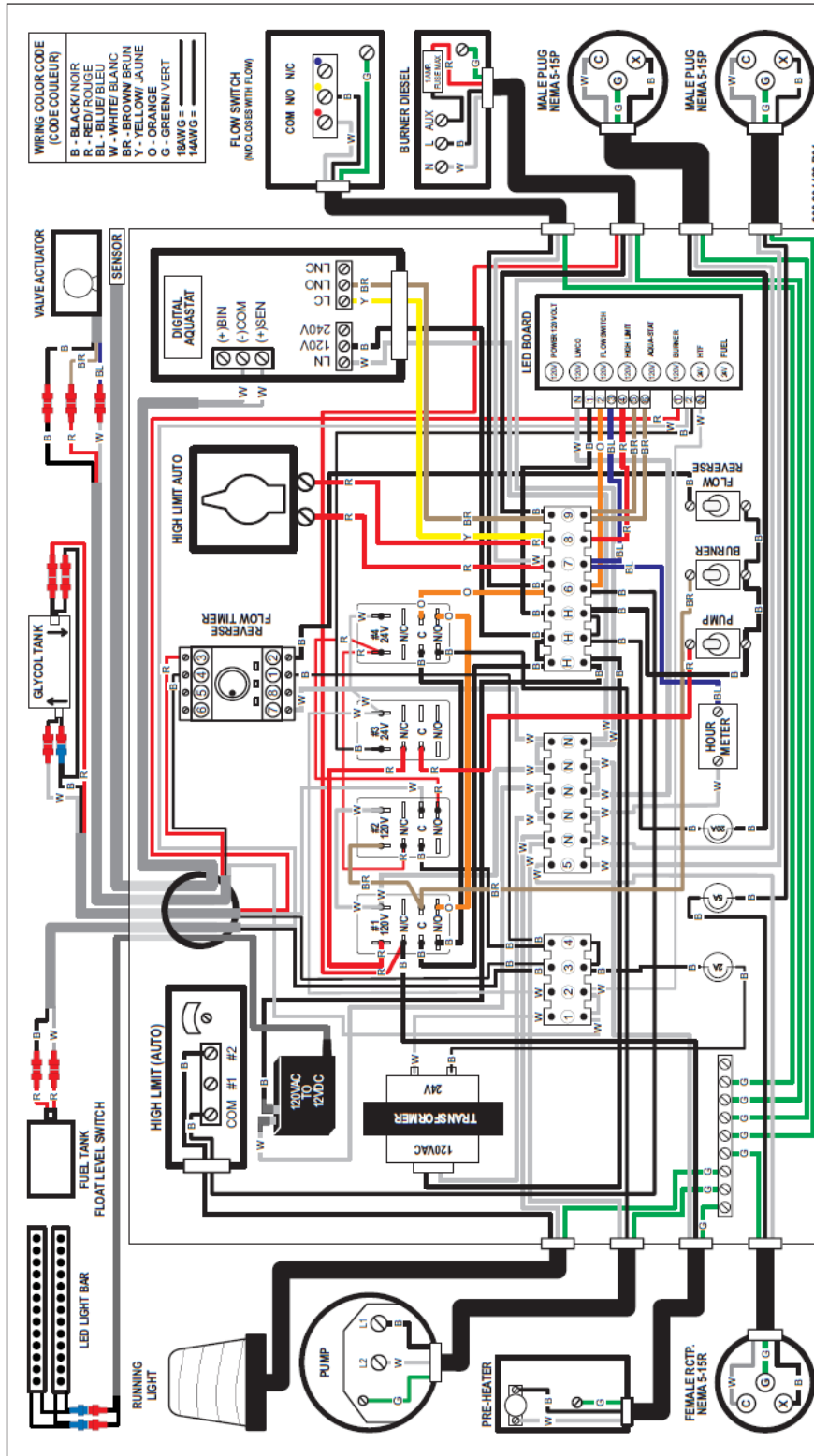

Figure 53 - 200 GTS C/W Optional Flow Reverser Electrical Schematic

Hose Reel Schematic

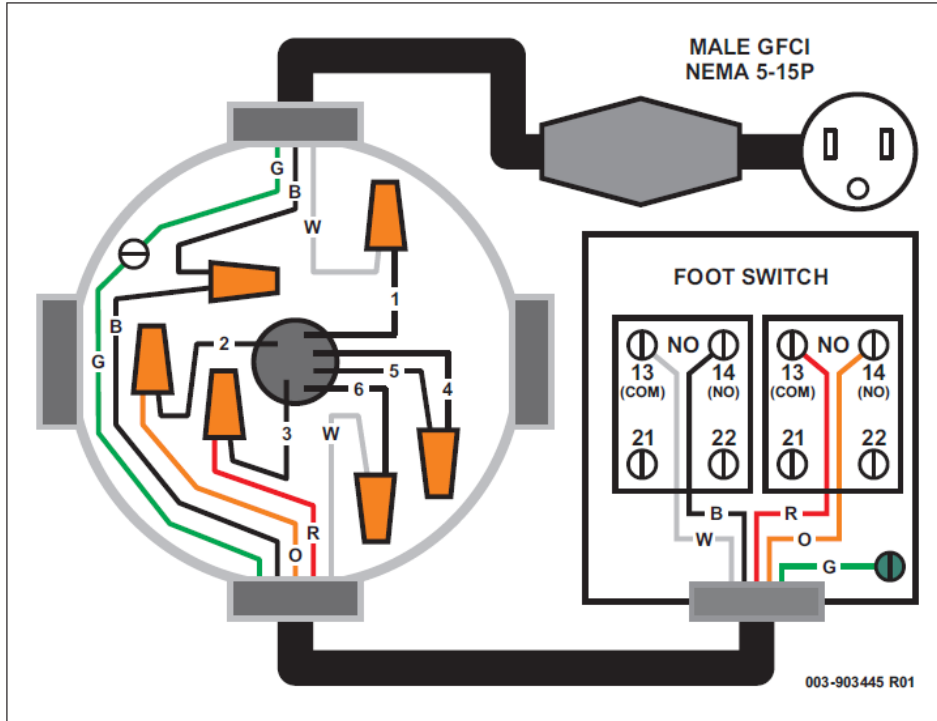

Figure 54 - Hose Reel Electrical Schematic

Trailer Schematics

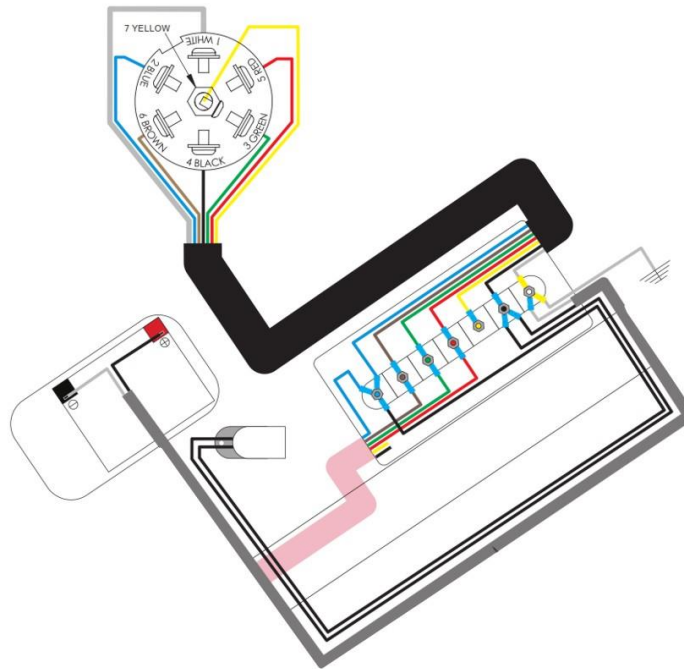

Figure 55 - Close-up View of Trailer Hook-up

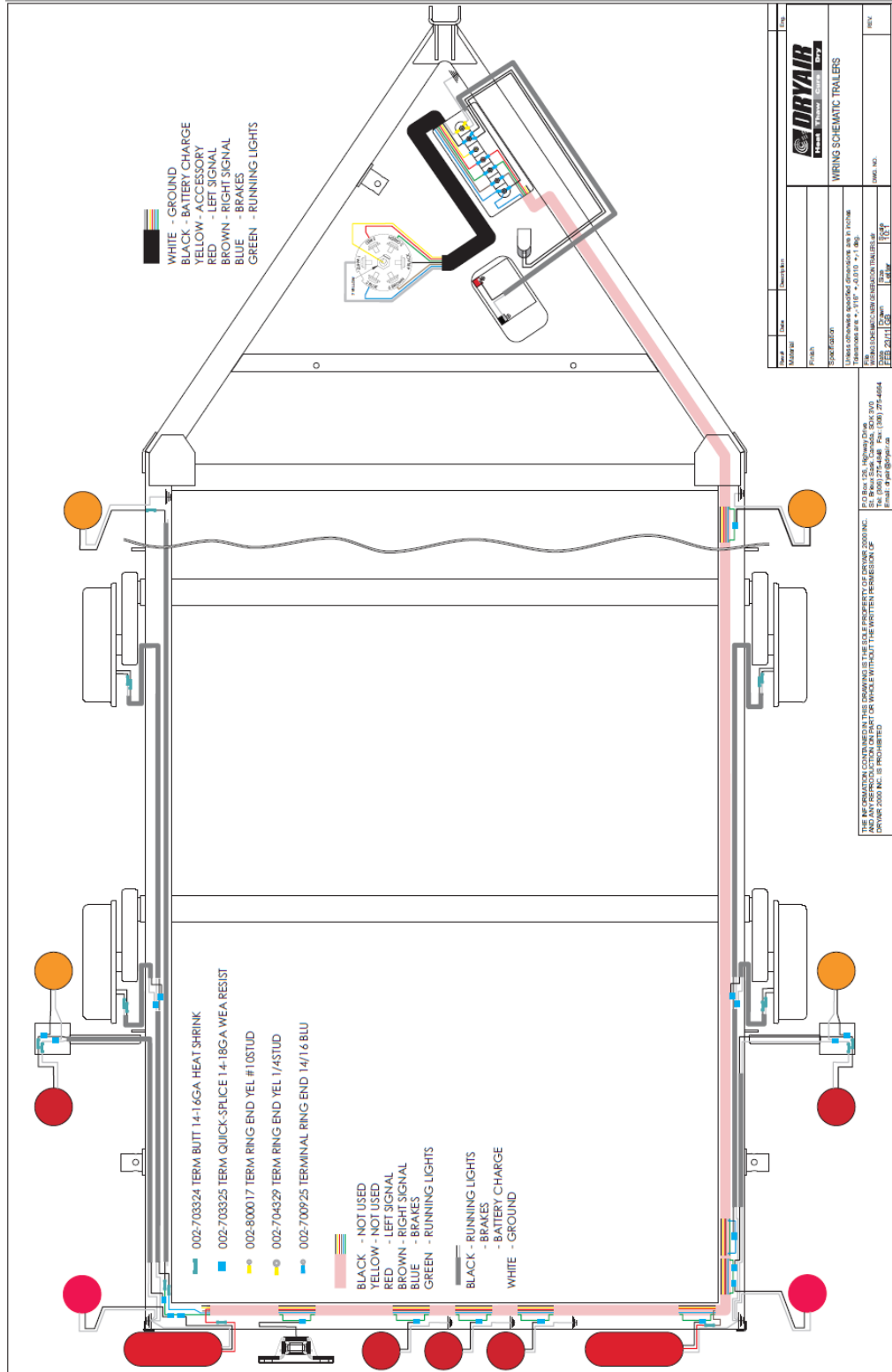

Figure 56 - Trailer Electrical Schematic

Heat Transfer Fluid Preheater Information

Function

- The design intention for the HTF preheater is to ensure a smooth start in cold environments. The preheater heats the glycol in the heat exchanger which in turn sends heated glycol to DRYAIR'S patented air and fuel preheater to provide a controlled constant air and fuel temperature thus providing smooth start operations in cold weather.
- While using the HTF preheater it is recommended to have a supply temperature to be between 140°F and 150°F (60°C to 65°C) before turning on the pump and burner switch. The estimated time before these temperatures can be achieved will depend on the ambient temperature outside. Basically, the colder environment outside the longer it will take to achieve the recommended supply temperature.

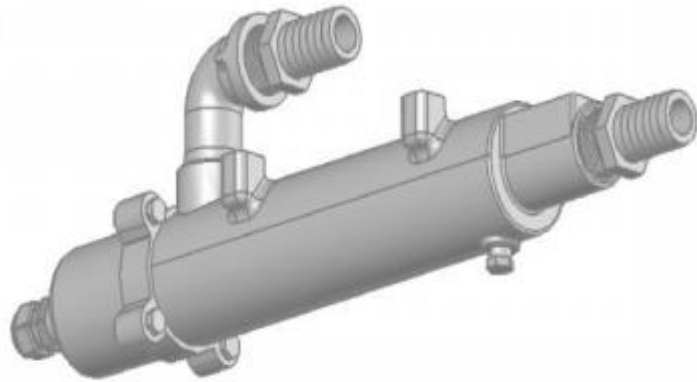

Figure 57 - HTF Preheater

Pros of Using HTF Preheater:

- Using the HTF preheater according to recommendations will ensure a smooth start in all weather conditions, thus providing a superior product to all users.
- Allows the machine to operate in even the coldest environments with fewer combustion issues.
- Less down time and reduced fuel costs as units will start and run at maximum efficiency.
- Having warm glycol reduces initial load to the glycol circulating pump at start up.
- Increase heat exchanger longevity and efficiency.
- Decreases maintenance costs due to the reduced stress on all components during cold startups.

Cons of Not Using HTF Preheater:

- Burner may not fire, which in turn will create down time on job locations. For competitor's units that do not have a preheater option, this typically means bringing the unit off site to a heated shop to allow the unit to thaw out before it will fire. Again, it will depend on the ambient temperature inside the shop as to how long this will take but in any event, it will take much longer compared to using the preheater on the DRYAIR unit.

- If the unit does start in cold temperatures, there is potential for the heat exchanger to accumulate soot due to not having a controlled environment of air and fuel going into the burner. Sooting will stop after the unit warms up if the settings on the burner are correct. Every 1 mm of soot accumulated on the heat exchanger results in a 5% loss of efficiency compared to a clean exchanger. Running the preheater on the DRYAIR unit eliminates the need to adjust burner settings in reaction to changing weather conditions.
- Decreases heat exchanger service life.
- Increases maintenance costs due to added stress on all components during cold startups.

In Conclusion

Using the preheater as instructed in the manual will allow you to operate DRYAIR units in colder climates without sacrificing efficiency or long-term reliability of the unit.

DRYAIR recommends planning ahead and starting the preheater to allow it to run while the unit is in transit to the jobsite (running on generator power) and while operators are reeling out and placing hose on the site. This will still make for productive use of the time while allowing the unit to benefit from the patented preheater feature.

If the operator decides they do not want to wait for the preheater to work, the DRYAIR unit will perform just like any of our competitor's units that do not have a preheater option.



Material Safety Data Sheets

The Material Safety Data Sheets (MSDS) included with this manual have been provided by DRYAIR's suppliers.



Test Certificate

Bolt-on Lifting Lug System for DryAir 200GTS Greenthaw System

Certificate No.: 612

Project No.: I18032

Identification of Test Object:

- Lifting Lug Assembly for DryAir 200GTS
- Lugs (qty. 4) constructed of laser cut and bent 1/4 in. steel plate (Dwg No. 004-904312RM-R01 or 004-904311RM-R01) with 1 3/4 in. hole for clevis pin or hook.
 - Tested with high strength chain but intended to be used with an engineered sling with four 7 ft legs.
 - Attached to structure using qty. four 1/2 in. Grade 5 fasteners.

Manufacturer: Dryair
 (Tested assembly) St. Brieux, SK

Test Location: Prairie Agricultural Machinery Institute (PAMI), Humboldt, SK

Test Date: June 21, 2018

Regulations Tested To:

Current Province of Saskatchewan "Occupational Health and Safety Regulations, 1996" Chapter O-1.1 Reg 1, Part XIII, Section 206 and Part XIV, Sections 230 and 231.

Test Description:

An applied force of at least five times the maximum weight of the 200GTS System is applied simultaneously to all four bolt-on lifting lugs using four 7-ft long chains to simulate the engineered sling that will be provided with each unit.

Tests Result Required:

The four bolt-on lifting lugs must withstand a total applied load of at least five times the maximum weight of the 200GTS system without failing. The maximum load applied divided by five will define the load rating of the four lugs together.

Test Equipment:

Description	Date Calibrated	Calibration Due Date
Load Cell Serial No. 13479	October 9, 2017	October 9, 2018
Indicator Serial No. 17168961	Verified with load cell June 5, 2018	

Test Results:

A total maximum force of 30,296 lb (134.8 kN) was simultaneously applied to the four lugs. At the conclusion of the test, a small amount of plastic deformation was observed on one corner of the structure. However, no failure of the lug components occurred during the test. This result allows the four lugs, when used together on the 200GTS assembly, to be rated to lift a maximum total weight of 6,059 lb (2,748 kg). Each individual lug can be rated at no more than one quarter of the total rating or 1,515 lb (687.1 kg).

I hereby certify these results meet or exceed the requirements of the performance regulations.

This certificate is based on results obtained by testing the equipment as indicated herein.

This Test Certificate shall not be reproduced except in full, without written approval of PAMI.



Certified by: Larry Jorgenson, P.Eng
 Program Manager – Industry and Transportation Services

Date: July 20, 2018

Test Procedure:

1. A sample (frame only) of the 200GTS assembly with four bolt-on lifting lugs installed (**Figure 1**) was placed on a rigid test bed and secured with chains to allow the application of a vertical force perpendicular to the mounting surface.
2. The 200GTS product is intended to be lifted from a single point using an engineered sling as shown in **Figure 2**. For test purposes, the sling was substituted with chains to ensure the maximum force could be applied to the lugs (**Figure 3**).
3. A forklift with a fabricated attachment was used to apply the load.
4. The applied force was measured using a load cell installed between the forklift and shackle.
5. An indicator connected to the load cell provided an instantaneous readout of applied load (**Figure 4**).
6. The force application was recorded on video.
7. The applied force was gradually increased from zero to approximately 30,000 lbf (134 kN). This target was based on being at least five times the maximum weight of the fully assembled 200GTS product.
8. The maximum force was held for at least ten seconds, then removed. The peak load applied was retrieved from the indicator (**Figure 4**) and used to calculate a load rating for the lugs as follows (imperial units):

Peak total load applied = 30,296 lbf

Allowable maximum rating for four lugs as a system using a 5X design factor or working load limit =

$$30,296 \text{ lb} / 5 = 6,059 \text{ lb}$$

This is the maximum allowable total weight of the final assembly that can be lifted with the four lugs installed as tested. The Client indicated the maximum weight of the complete product would be between 5,000 and 5,400 lb with a normal average weight being under 5,000 lb. Therefore, the 6,059.2 lb rating is adequate.

Assuming each individual lug shared the load equally (likely, when the polyester sling is used), the individual lugs could be rated up to.

$$6,059 \text{ lb} / 4 = 1,515 \text{ lb}$$

PAMI recommends the above ratings to be conspicuously marked on the product on or near the lugs.



Figure 1. Bare 200GTS assembly with lifting lugs attached at the four corners.

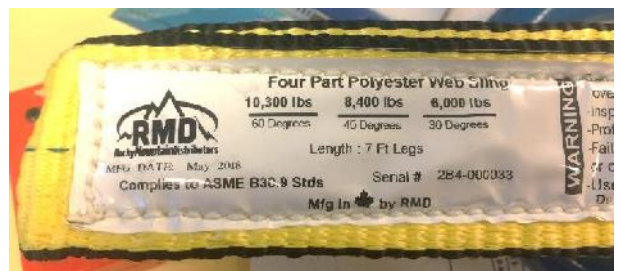

Figure 2. Polyester web sling intended to be used to lift 200GTS at four lifting lug locations.



Figure 3. Test set-up for application of force.



Figure 4. Angle iron deformation at 66.7 kN (15,000 lb) applied force.



SAFETY DATA SHEET

Issuing Date 03-Jun-2019

Revision date 03-Jun-2019

Revision Number 1

1. Identification

Product identifier

Product Name BOSS Chill Propylene Glycol

Other means of identification

Product Code(s) GHSRBS-041

UN/ID no. UN 3082

Synonyms None

Recommended use of the chemical and restrictions on use

Recommended use Heat transfer medium

Restrictions on use No information available

Details of the supplier of the safety data sheet

Initial supplier identifier

BOSS Lubricants

Manufacturer Address

6303 30 ST SE Calgary, AB T2C 1R4

Emergency telephone number

Initial supplier phone number (800) 844-9457
Emergency Telephone Chemtrec 1-800-424-9300

2. Hazard(s) identification

Classification

Not a hazardous substance or mixture according to the Globally Harmonized System (GHS) and Canada's Hazardous Products Regulations

Label elements

Hazard statements

Not a hazardous substance or mixture according to the Globally Harmonized System (GHS) and Canada's Hazardous Products Regulations.



Precautionary Statements - Disposal

Dispose of contents/container in accordance with local, regional, national, and international regulations as applicable

Other information**3. Composition/information on ingredients****Substance**

Chemical name	CAS No.	Weight-%	Hazardous Material Information Review Act registry number (HMIRA registry #)	Date HMIRA filed and date exemption granted (if applicable)
Water	7732-18-5	0.1 - 1	-	
Propylene glycol	57-55-6	80 - 100	-	
PROPRIETARY ADDITIVES	PROPRIETARY	1 - 5	-	

If CAS number is "proprietary", the specific chemical identity and percentage of composition has been withheld as a trade secret.

4. First-aid measures**Description of first aid measures**

Inhalation	Remove to fresh air. If not breathing, give artificial respiration. IF exposed or concerned: Get medical advice/attention.
Eye contact	IF IN EYES: Rinse cautiously with water for several minutes. Remove contact lenses, if present and easy to do. Continue rinsing. Get medical attention if irritation develops and persists.
Skin contact	Wash off immediately with soap and plenty of water while removing all contaminated clothes and shoes. Get medical attention if symptoms occur.
Ingestion	Do NOT induce vomiting. Call a physician or poison control center immediately. If vomiting occurs spontaneously, keep head below hips to prevent aspiration. Never give anything by mouth to an unconscious person.

Most important symptoms and effects, both acute and delayed

Symptoms Prolonged contact may cause redness and irritation.

Indication of any immediate medical attention and special treatment needed

Note to physicians Treat symptomatically.

5. Fire-fighting measures

Suitable Extinguishing Media	Carbon dioxide (CO ₂). Foam. Dry chemical. Water spray or fog. Alcohol resistant foam.
Unsuitable extinguishing media	Do not scatter spilled material with high pressure water streams.
Specific hazards arising from the chemical	Use water spray to cool fire-exposed containers and structures. Isolate and restrict area access. Violent steam generation or eruption may occur upon application of direct water stream to hot liquids. Container may rupture from gas generation in a fire situation. Fight fire from a safe distance and from a protected location. Do not direct a solid stream of water or foam into hot, burning pools; this may cause frothing and increase fire intensity. Consider use of unmanned hose holder or monitor nozzles.
Explosion data	
Sensitivity to mechanical impact	None.
Sensitivity to static discharge	None.
Special protective equipment for fire-fighters	Firefighters should wear self-contained breathing apparatus and full firefighting turnout gear. Use personal protection equipment.

6. Accidental release measures

Personal precautions, protective equipment and emergency procedures

Personal precautions Use personal protective equipment as required. See section 8 for more information. Ensure adequate ventilation.

Methods and material for containment and cleaning up

Methods for containment Stop leak if you can do it without risk. Keep out of drains, sewers, ditches and waterways. Ventilate the area. Avoid breathing vapors or mists.

Methods for cleaning up Cover liquid spill with sand, earth or other noncombustible absorbent material. Prevent product from entering drains.

7. Handling and storage

Precautions for safe handling

Advice on safe handling Avoid breathing dust/fume/gas/mist/vapors/spray. Avoid contact with skin, eyes or clothing. Use only with adequate ventilation. Handle in accordance with good industrial hygiene and safety practice. Do not eat, drink or smoke when using this product. Do not ingest. If swallowed then seek immediate medical assistance. For industrial use only.

Conditions for safe storage, including any incompatibilities

Storage Conditions Keep container tightly closed in a dry and well-ventilated place. Keep away from heat, sparks, flame and other sources of ignition (i.e., pilot lights, electric motors and static electricity). Do not contaminate food or feed stuffs. Store only in containers resistant to alkaline solutions with a pH of 9.0 to 12.0.

8. Exposure controls/personal protection

Control parameters

Exposure Limits This product, as supplied, does not contain any hazardous materials with occupational exposure limits established by the region specific regulatory bodies.

Appropriate engineering controls

Engineering controls Ensure adequate ventilation, especially in confined areas.

Individual protection measures, such as personal protective equipment

Eye/face protection Wear safety glasses with side shields (or goggles). If splashes are likely to occur, wear safety glasses with side-shields. Avoid contact with eyes.

Hand protection Wear suitable gloves.

Skin and body protection Wear suitable protective clothing.

Respiratory protection No protective equipment is needed under normal use conditions. If exposure limits are exceeded or irritation is experienced, ventilation and evacuation may be required.

General hygiene considerations Handle in accordance with good industrial hygiene and safety practice.

9. Physical and chemical properties

Information on basic physical and chemical properties

Physical state Liquid
Appearance No information available
Color purple
Odor Odorless
Odor threshold No information available

<u>Property</u>	<u>Values</u>	<u>Remarks • Method</u>
pH	9.0– 10.5	
Melting point / freezing point	No data available	None known
Boiling point / boiling range	188 °C / 317 °F	ASTM D7213
Flash point	116 °C / 240 °F	ASTM D93
Evaporation rate	No data available	None known
Flammability (solid, gas)	No data available	None known
Flammability Limit in Air		None known
Upper flammability or explosive limits	No data available	
Lower flammability or explosive limits	No data available	
Vapor pressure	No data available	None known
Vapor density	No data available	None known
Relative density	No data available	None known
Water solubility	completely soluble	
Solubility in other solvents	No data available	None known

Partition coefficient	No data available	None known
Autoignition temperature	No data available	None known
Decomposition temperature	No data available	None known
Kinematic viscosity	No data available	None known
Dynamic viscosity	No data available	None known

Other information

Explosive properties	No information available.
Oxidizing properties	No information available.
Softening point	No information available
Molecular weight	No information available
VOC Content (%)	No information available
Liquid Density	No information available
Bulk density	No information available

10. Stability and reactivity

Reactivity	No information available.
Chemical stability	Stable under normal conditions.
Possibility of hazardous reactions	None under normal processing.
Conditions to avoid	Heat, flames and sparks.
Incompatible materials	Strong oxidizing agents. Strong acids.
Hazardous decomposition products	Thermal decomposition can lead to release of irritating and toxic gases and vapors.

11. Toxicological information**Information on likely routes of exposure****Product Information**

Inhalation	No known effects under normal use conditions.
Eye contact	Irritating to eyes.
Skin contact	Avoid contact with skin and clothing.
Ingestion	Harmful if swallowed. Ingestion of larger amounts may cause defects to the central nervous system (e.g. dizziness, headache). Ingestion may cause gastrointestinal irritation, nausea, vomiting and diarrhea. May cause adverse kidney effects.

Symptoms related to the physical, chemical and toxicological characteristics

Symptoms	No information available.
----------	---------------------------

Acute toxicity

Numerical measures of toxicity
No information available

Unknown acute toxicity No information available
Product Information

Chemical name	Oral LD50	Dermal LD50	Inhalation LC50
Propylene glycol 57-55-6	= 20 g/kg (Rat)	= 20800 mg/kg (Rabbit)	Not available

Delayed and immediate effects as well as chronic effects from short and long-term exposure

Skin corrosion/irritation Based on available data, the classification criteria are not met.

Serious eye damage/eye irritation Based on available data, the classification criteria are not met.

Respiratory or skin sensitization Based on available data, the classification criteria are not met.

Germ cell mutagenicity Based on available data, the classification criteria are not met.

Carcinogenicity Based on available data, the classification criteria are not met.

Reproductive toxicity Based on available data, the classification criteria are not met.

STOT - single exposure Based on available data, the classification criteria are not met.

STOT - repeated exposure Based on available data, the classification criteria are not met.

Aspiration hazard No information available.

12. Ecological information

Ecotoxicity Harmful to aquatic life.

Persistence and degradability No information available.

Bioaccumulation No information available.

Other adverse effects No information available.

13. Disposal considerations

Waste treatment methods

Waste from residues/unused products Dispose of waste in accordance with environmental legislation.

Contaminated packaging Do not reuse empty containers.

14. Transport information

<u>Transport Canada</u>	Not regulated
<u>TDG</u>	Not regulated
<u>DOT</u>	Not regulated unless shipping container holds at least 5,000 pounds.
UN/ID no.	UN 3082
Hazard class	9
Packing group	III
<u>MEX</u>	Not regulated
<u>ICAO (air)</u>	no data available
<u>IATA</u>	no data available
<u>IMDG</u>	no data available
<u>RID</u>	no data available
<u>ADR</u>	no data available
<u>ADN</u>	no data available

15. Regulatory information

Safety, health and environmental regulations/legislation specific for the substance or mixture

International Regulations

The Montreal Protocol on Substances that Deplete the Ozone Layer Not applicable

The Stockholm Convention on Persistent Organic Pollutants Not applicable

The Rotterdam Convention Not applicable

International Inventories

TSCA	Complies.
DSL/NDSL	Complies.
EINECS/ELINCS	Contact supplier for inventory compliance status.
ENCS	Contact supplier for inventory compliance status.
IECSC	Contact supplier for inventory compliance status.
KECL	Contact supplier for inventory compliance status.
PICCS	Contact supplier for inventory compliance status.
AICS	Contact supplier for inventory compliance status.

Legend:

TSCA - United States Toxic Substances Control Act Section 8(b) Inventory

DSL/NDSL - Canadian Domestic Substances List/Non-Domestic Substances List

EINECS/ELINCS - European Inventory of Existing Chemical Substances/European List of Notified Chemical Substances

ENCS - Japan Existing and New Chemical Substances

IECSC - China Inventory of Existing Chemical Substances

KECL - Korean Existing and Evaluated Chemical Substances

PICCS - Philippines Inventory of Chemicals and Chemical Substances

AICS - Australian Inventory of Chemical Substances

16. Other information

NFPA	Health hazards 2	Flammability 1	Instability 0	Physical and chemical properties -
HMIS	Health hazards 2	Flammability 1	Physical hazards 0	Personal protection X

Key or legend to abbreviations and acronyms used in the safety data sheet**Legend Section 8: EXPOSURE CONTROLS/PERSONAL PROTECTION**

TWA	TWA (time-weighted average)	STEL	STEL (Short Term Exposure Limit)
Ceiling	Maximum limit value	*	Skin designation

Key literature references and sources for data used to compile the SDS

Agency for Toxic Substances and Disease Registry (ATSDR)
 U.S. Environmental Protection Agency ChemView Database
 European Food Safety Authority (EFSA)
 EPA (Environmental Protection Agency)
 Acute Exposure Guideline Level(s) (AEGl(s))
 U.S. Environmental Protection Agency Federal Insecticide, Fungicide, and Rodenticide Act
 U.S. Environmental Protection Agency High Production Volume Chemicals
 Food Research Journal
 Hazardous Substance Database
 International Uniform Chemical Information Database (IUCLID)
 Japan GHS Classification
 Australia National Industrial Chemicals Notification and Assessment Scheme (NICNAS)
 NIOSH (National Institute for Occupational Safety and Health)
 National Library of Medicine's ChemID Plus (NLM CIP)
 National Library of Medicine's PubMed database (NLM PUBMED)
 National Toxicology Program (NTP)
 New Zealand's Chemical Classification and Information Database (CCID)
 Organization for Economic Co-operation and Development Environment, Health, and Safety Publications
 Organization for Economic Co-operation and Development High Production Volume Chemicals Program
 Organization for Economic Co-operation and Development Screening Information Data Set
 RTECS (Registry of Toxic Effects of Chemical Substances)
 World Health Organization

Issuing Date 03-Jun-2019

Revision date 04-Jun-2019

Revision Note No information available.

Disclaimer

The information provided in this Safety Data Sheet is correct to the best of our knowledge, information and belief at the date of its publication. The information given is designed only as a guidance for safe handling, use, processing, storage, transportation, disposal and release and is not to be considered a warranty or quality specification. The information relates only to the specific material designated and may not be valid for such material used in combination with any other materials or in any process, unless specified in the text.

End of Safety Data Sheet

Data for Regulatory Rules

Region	Template name	Revision Note
Canada	HGHS	2.0

GHS Product Information

pH	9.0– 10.5
Physical state	Liquid
Flash point °C	116
Boiling point / boiling range °C	188

Component Information

Canada

GHS Classification

Not Hazardous	Not a hazardous substance or mixture according to the Globally Harmonized System (GHS) and Canada's Hazardous Products Regulations
Precautionary Statements - Disposal	Dispose of contents/container in accordance with local, regional, national, and international regulations as applicable



SAFETY DATA SHEET

DOW CHEMICAL CANADA ULC

Product name: DOWFROST™ Heat Transfer Fluid

Issue Date: 12/16/2019

Print Date: 12/17/2019

DOW CHEMICAL CANADA ULC encourages and expects you to read and understand the entire (M)SDS, as there is important information throughout the document. We expect you to follow the precautions identified in this document unless your use conditions would necessitate other appropriate methods or actions.

1. IDENTIFICATION

Product name: DOWFROST™ Heat Transfer Fluid

Recommended use of the chemical and restrictions on use

Identified uses: Intended as a heat transfer fluid for closed-loop systems. This product is acceptable for use where there is possibility of incidental food contact and as a product for use in the immersion or spray freezing of wrapped meat and packaged poultry products. We recommend that you use this product in a manner consistent with the listed use. If your intended use is not consistent with the stated use, please contact your sales or technical service representative.

COMPANY IDENTIFICATION

DOW CHEMICAL CANADA ULC
#2400, 215 - 2ND STREET S.W.
CALGARY AB T2P 1M4
CANADA

Customer Information Number:

800-258-2436
SDSQuestion@dow.com

EMERGENCY TELEPHONE NUMBER

24-Hour Emergency Contact (transportation emergencies only): 1-800-424-9300

Local Emergency Contact (transportation emergencies only): 1-800-424-9300

24-Hour Emergency Contact: 1-989-636-4400

2. HAZARDS IDENTIFICATION

Hazard classification

This product is not hazardous under the criteria of the Hazardous Products Regulation (HPR) as implemented under the Workplace Hazardous Materials Information System (WHMIS 2015).

Other hazards

No data available

3. COMPOSITION/INFORMATION ON INGREDIENTS

This product is a mixture.

Component	CASRN	Concentration (w/w)
Propylene glycol	57-55-6	> 95.0 %
Inorganic corrosion inhibitor	not hazardous	< 3.0 %
Water	7732-18-5	< 3.0 %

4. FIRST AID MEASURES

Description of first aid measures

General advice:

If potential for exposure exists refer to Section 8 for specific personal protective equipment.

Inhalation: Move person to fresh air; if effects occur, consult a physician.

Skin contact: Wash off with plenty of water.

Eye contact: Flush eyes thoroughly with water for several minutes. Remove contact lenses after the initial 1-2 minutes and continue flushing for several additional minutes. If effects occur, consult a physician, preferably an ophthalmologist.

Ingestion: Rinse mouth with water. No emergency medical treatment necessary.

Most important symptoms and effects, both acute and delayed:

Aside from the information found under Description of first aid measures (above) and Indication of immediate medical attention and special treatment needed (below), any additional important symptoms and effects are described in Section 11: Toxicology Information.

Indication of any immediate medical attention and special treatment needed

Notes to physician: No specific antidote. Treatment of exposure should be directed at the control of symptoms and the clinical condition of the patient.

5. FIREFIGHTING MEASURES

Extinguishing media

Suitable extinguishing media: Water fog or fine spray.. Dry chemical fire extinguishers.. Carbon dioxide fire extinguishers.. Foam.. Alcohol resistant foams (ATC type) are preferred. General purpose synthetic foams (including AFFF) or protein foams may function, but will be less effective..

Unsuitable extinguishing media: Do not use direct water stream.. May spread fire..

Special hazards arising from the substance or mixture

Hazardous combustion products: During a fire, smoke may contain the original material in addition to combustion products of varying composition which may be toxic and/or irritating.. Combustion products may include and are not limited to:.. Carbon monoxide.. Carbon dioxide..

Unusual Fire and Explosion Hazards: Container may rupture from gas generation in a fire situation.. Violent steam generation or eruption may occur upon application of direct water stream to hot liquids..

Advice for firefighters

Fire Fighting Procedures: Keep people away. Isolate fire and deny unnecessary entry.. Use water spray to cool fire exposed containers and fire affected zone until fire is out and danger of reignition has passed.. Fight fire from protected location or safe distance. Consider the use of unmanned hose holders or monitor nozzles.. Immediately withdraw all personnel from the area in case of rising sound from venting safety device or discoloration of the container.. Burning liquids may be extinguished by dilution with water.. Do not use direct water stream. May spread fire.. Move container from fire area if this is possible without hazard.. Burning liquids may be moved by flushing with water to protect personnel and minimize property damage..

Special protective equipment for firefighters: Wear positive-pressure self-contained breathing apparatus (SCBA) and protective fire fighting clothing (includes fire fighting helmet, coat, trousers, boots, and gloves).. If protective equipment is not available or not used, fight fire from a protected location or safe distance..

6. ACCIDENTAL RELEASE MEASURES

Personal precautions, protective equipment and emergency procedures: Use appropriate safety equipment. For additional information, refer to Section 8, Exposure Controls and Personal Protection.

Environmental precautions: Prevent from entering into soil, ditches, sewers, waterways and/or groundwater. See Section 12, Ecological Information.

Methods and materials for containment and cleaning up: Small spills: Absorb with materials such as: Cat litter. Sawdust. Vermiculite. Zorb-all®. Collect in suitable and properly labeled containers. Large spills: Dike area to contain spill. Recover spilled material if possible. See Section 13, Disposal Considerations, for additional information.

7. HANDLING AND STORAGE

Precautions for safe handling: No special precautions required. Keep container closed. See Section 8, EXPOSURE CONTROLS AND PERSONAL PROTECTION. Spills of these organic materials on hot fibrous insulations may lead to lowering of the autoignition temperatures possibly resulting in spontaneous combustion.

Conditions for safe storage: Do not store in: Galvanized steel. Opened or unlabeled containers. Store in original unopened container. See Section 10 for more specific information. Additional storage

and handling information on this product may be obtained by calling your sales or customer service contact.

Storage stability

Shelf life: Use within 60 Month

8. EXPOSURE CONTROLS/PERSONAL PROTECTION

Control parameters

If exposure limits exist, they are listed below. If no exposure limits are displayed, then no values are applicable.

Consult local authorities for recommended exposure limits.

Component	Regulation	Type of listing	Value
Propylene glycol	US WEEL	TWA	10 mg/m3
	CA ON OEL	TWAEV Total	155 mg/m3 50 ppm
	CA ON OEL	TWAEV	10 mg/m3
	Further information: C: For assessing the visibility in a work environment where 1,2-propylene glycol aerosol is present.		
	CA ON OEL	TWA	155 mg/m3 50 ppm
	CA ON OEL	TWA	10 mg/m3
	Further information: (c): For assessing the visibility in a work environment where 1,2-propylene glycol aerosol is present		
	CA ON OEL	TWA Vapour and aerosols	155 mg/m3 50 ppm
	CA ON OEL	TWA aerosol	10 mg/m3
	Further information: (c): For assessing the visibility in a work environment where 1,2-propylene glycol aerosol is present		

Exposure controls

Engineering controls: Use local exhaust ventilation, or other engineering controls to maintain airborne levels below exposure limit requirements or guidelines. If there are no applicable exposure limit requirements or guidelines, general ventilation should be sufficient for most operations. Local exhaust ventilation may be necessary for some operations.

Individual protection measures

Eye/face protection: Use safety glasses (with side shields).

Skin protection

Hand protection: Use gloves chemically resistant to this material when prolonged or frequently repeated contact could occur. Examples of preferred glove barrier materials include: Butyl rubber. Natural rubber ("latex"). Neoprene. Nitrile/butadiene rubber ("nitrile" or "NBR"). Polyethylene. Ethyl vinyl alcohol laminate ("EVAL"). Polyvinyl chloride ("PVC" or "vinyl"). Avoid gloves made of: Polyvinyl alcohol ("PVA"). NOTICE: The selection of a specific glove for a particular application and duration of use in a workplace should also take into account all relevant workplace factors such as, but not limited to: Other chemicals which may be handled, physical requirements (cut/puncture protection, dexterity, thermal protection), potential body reactions to glove materials, as well as the instructions/specifications provided by the glove supplier.

Other protection: Wear clean, body-covering clothing.

Respiratory protection: Respiratory protection should be worn when there is a potential to exceed the exposure limit requirements or guidelines. If there are no applicable exposure limit

requirements or guidelines, wear respiratory protection when adverse effects, such as respiratory irritation or discomfort have been experienced, or where indicated by your risk assessment process. In misty atmospheres, use an approved particulate respirator. The following should be effective types of air-purifying respirators: Organic vapor cartridge with a particulate pre-filter.

9. PHYSICAL AND CHEMICAL PROPERTIES

Appearance

Physical state	Liquid.
Color	Colorless
Odor	Characteristic
Odor Threshold	No test data available
pH	10.0 50% <i>Literature</i>
Melting point/range	Not applicable to liquids
Freezing point	supercools
Boiling point (760 mmHg)	152 °C <i>Literature</i>
Flash point	closed cup 104 °C <i>Pensky-Martens Closed Cup ASTM D 93</i> (based on major component), Propylene glycol. open cup <i>Cleveland Open Cup ASTM D92</i> None
Evaporation Rate (Butyl Acetate = 1)	<0.5 <i>Estimated.</i>
Flammability (solid, gas)	Not applicable to liquids
Flammability (liquids)	Not expected to be a static-accumulating flammable liquid.
Lower explosion limit	2.6 % vol <i>Literature</i> Propylene glycol.
Upper explosion limit	12.5 % vol <i>Literature</i> Propylene glycol.
Vapor Pressure	2.2 mmHg <i>Literature</i>
Relative Vapor Density (air = 1)	>1.0 <i>Literature</i>
Relative Density (water = 1)	1.05 at 20 °C / 20 °C <i>Literature</i>
Water solubility	<i>Literature</i> completely soluble
Partition coefficient: n-octanol/water	No data available
Auto-ignition temperature	371 °C <i>Literature</i> Propylene glycol.
Decomposition temperature	No test data available
Kinematic Viscosity	43.4 cSt at 20 °C <i>Literature</i>
Explosive properties	No data available
Oxidizing properties	No data available
Molecular weight	76.9 g/mol <i>Literature</i>

NOTE: The physical data presented above are typical values and should not be construed as a specification.

10. STABILITY AND REACTIVITY

Reactivity: No data available

Chemical stability: Stable under recommended storage conditions. See Storage, Section 7.
Hygroscopic

Possibility of hazardous reactions: Polymerization will not occur.

Conditions to avoid: Exposure to elevated temperatures can cause product to decompose. Generation of gas during decomposition can cause pressure in closed systems. Avoid direct sunlight or ultraviolet sources.

Incompatible materials: Avoid contact with: Strong acids. Strong bases. Strong oxidizers.

Hazardous decomposition products: Decomposition products depend upon temperature, air supply and the presence of other materials.. Decomposition products can include and are not limited to: Aldehydes.. Alcohols.. Ethers.. Organic acids..

11. TOXICOLOGICAL INFORMATION

Toxicological information appears in this section when such data is available.

Information on likely routes of exposure

Ingestion, Inhalation, Skin contact, Eye contact.

Acute toxicity (represents short term exposures with immediate effects - no chronic/delayed effects known unless otherwise noted)

Acute oral toxicity

Very low toxicity if swallowed. Harmful effects not anticipated from swallowing small amounts.

For the major component(s): Propylene glycol.
LD50, Rat, > 20,000 mg/kg

Information for components:

Propylene glycol

LD50, Rat, > 20,000 mg/kg

Inorganic corrosion inhibitor

LD50, Rat, female, > 2,000 mg/kg No deaths occurred at this concentration.

Acute dermal toxicity

Prolonged skin contact is unlikely to result in absorption of harmful amounts.

For the major component(s): Propylene glycol.
LD50, Rabbit, > 20,000 mg/kg

Information for components:

Propylene glycol

LD50, Rabbit, > 2,000 mg/kg No deaths occurred at this concentration.

Inorganic corrosion inhibitor

LD50, Rabbit, > 5,000 mg/kg

Acute inhalation toxicity

At room temperature, exposure to vapor is minimal due to low volatility. Mist may cause irritation of upper respiratory tract (nose and throat).

For the major component(s):

LC50, Rat, 4 Hour, vapour, 6.15 mg/l No deaths occurred following exposure to a saturated atmosphere.

Information for components:

Propylene glycol

LC50, Rabbit, 2 Hour, dust/mist, 317.042 mg/l No deaths occurred at this concentration.

Inorganic corrosion inhibitor

Based on information for a similar material: Maximum attainable concentration. LC50, Rat, male and female, 4 Hour, dust/mist, > 0.83 mg/l No deaths occurred at this concentration.

Skin corrosion/irritation

Based on information for component(s):

Prolonged contact is essentially nonirritating to skin.

Repeated contact may cause flaking and softening of skin.

Information for components:

Propylene glycol

Prolonged contact is essentially nonirritating to skin.

Repeated contact may cause flaking and softening of skin.

Inorganic corrosion inhibitor

Prolonged contact may cause slight skin irritation with local redness.

Serious eye damage/eye irritation

Based on information for component(s):

May cause slight temporary eye irritation.

Corneal injury is unlikely.

Information for components:

Propylene glycol

May cause slight temporary eye irritation.

Corneal injury is unlikely.

Mist may cause eye irritation.

Inorganic corrosion inhibitor

May cause slight eye irritation.

May cause slight temporary corneal injury.

Dust may irritate eyes.
Mist may cause eye irritation.

Sensitization

For the major component(s):
Did not cause allergic skin reactions when tested in humans.

For respiratory sensitization:
No relevant data found.

Information for components:

Propylene glycol

Did not cause allergic skin reactions when tested in humans.

For respiratory sensitization:
No relevant data found.

Inorganic corrosion inhibitor

For similar material(s):
Did not demonstrate the potential for contact allergy in mice.

For respiratory sensitization:
No relevant data found.

Specific Target Organ Systemic Toxicity (Single Exposure)

Evaluation of available data suggests that this material is not an STOT-SE toxicant.

Information for components:

Propylene glycol

Evaluation of available data suggests that this material is not an STOT-SE toxicant.

Aspiration Hazard

Based on physical properties, not likely to be an aspiration hazard.

Information for components:

Propylene glycol

Based on physical properties, not likely to be an aspiration hazard.

Chronic toxicity (represents longer term exposures with repeated dose resulting in chronic/delayed effects - no immediate effects known unless otherwise noted)

Specific Target Organ Systemic Toxicity (Repeated Exposure)

In rare cases, repeated excessive exposure to propylene glycol may cause central nervous system effects.

Information for components:

Propylene glycol

In rare cases, repeated excessive exposure to propylene glycol may cause central nervous system effects.

Inorganic corrosion inhibitor

Based on available data, repeated exposures are not anticipated to cause significant adverse effects.

Carcinogenicity

Similar formulations did not cause cancer in laboratory animals.

Information for components:

Propylene glycol

Did not cause cancer in laboratory animals.

Inorganic corrosion inhibitor

No relevant data found.

Teratogenicity

For the major component(s): Did not cause birth defects or any other fetal effects in laboratory animals.

Information for components:

Propylene glycol

Did not cause birth defects or any other fetal effects in laboratory animals.

Inorganic corrosion inhibitor

For similar material(s): Did not cause birth defects or any other fetal effects in laboratory animals.

Reproductive toxicity

For the major component(s): In animal studies, did not interfere with reproduction. In animal studies, did not interfere with fertility.

Information for components:

Propylene glycol

In animal studies, did not interfere with reproduction. In animal studies, did not interfere with fertility.

Inorganic corrosion inhibitor

For similar material(s): In animal studies, did not interfere with reproduction.

Mutagenicity

In vitro genetic toxicity studies were negative. For the major component(s): Animal genetic toxicity studies were negative.

Information for components:

Propylene glycol

In vitro genetic toxicity studies were negative. Animal genetic toxicity studies were negative.

Inorganic corrosion inhibitor

In vitro genetic toxicity studies were negative.

12. ECOLOGICAL INFORMATION

Ecotoxicological information appears in this section when such data is available.

Toxicity

Propylene glycol

Acute toxicity to fish

Material is practically non-toxic to aquatic organisms on an acute basis (LC50/EC50/EL50/LL50 >100 mg/L in the most sensitive species tested).
LC50, Oncorhynchus mykiss (rainbow trout), static test, 96 Hour, 40,613 mg/l, OECD Test Guideline 203

Acute toxicity to aquatic invertebrates

LC50, Ceriodaphnia dubia (water flea), static test, 48 Hour, 18,340 mg/l, OECD Test Guideline 202

Acute toxicity to algae/aquatic plants

ErC50, Pseudokirchneriella subcapitata (green algae), 96 Hour, Growth rate inhibition, 19,000 mg/l, OECD Test Guideline 201

Toxicity to bacteria

NOEC, Pseudomonas putida, 18 Hour, > 20,000 mg/l

Chronic toxicity to aquatic invertebrates

NOEC, Ceriodaphnia dubia (water flea), semi-static test, 7 d, number of offspring, 13,020 mg/l

Inorganic corrosion inhibitor

Acute toxicity to fish

Material is practically non-toxic to aquatic organisms on an acute basis (LC50/EC50/EL50/LL50 >100 mg/L in the most sensitive species tested).
LC50, Leuciscus idus (Golden orfe), static test, 48 Hour, > 900 mg/l, Method Not Specified.

Persistence and degradability

Propylene glycol

Biodegradability: Material is readily biodegradable. Passes OECD test(s) for ready biodegradability. Biodegradation may occur under anaerobic conditions (in the absence of oxygen).

10-day Window: Pass

Biodegradation: 81 %

Exposure time: 28 d

Method: OECD Test Guideline 301F or Equivalent

10-day Window: Not applicable

Biodegradation: 96 %

Exposure time: 64 d

Method: OECD Test Guideline 306 or Equivalent

Theoretical Oxygen Demand: 1.68 mg/mg

Chemical Oxygen Demand: 1.53 mg/mg

Biological oxygen demand (BOD)

Incubation Time	BOD
5 d	69.000 %
10 d	70.000 %
20 d	86.000 %

Photodegradation

Atmospheric half-life: 10 Hour

Method: Estimated.

Inorganic corrosion inhibitor

Biodegradability: Biodegradation is not applicable.

Bioaccumulative potential

Propylene glycol

Bioaccumulation: Bioconcentration potential is low (BCF < 100 or Log Pow < 3).

Partition coefficient: n-octanol/water(log Pow): -1.07 Measured

Bioconcentration factor (BCF): 0.09 Estimated.

Inorganic corrosion inhibitor

Bioaccumulation: No bioconcentration is expected because of the relatively high water solubility.

Mobility in soil

Propylene glycol

Given its very low Henry's constant, volatilization from natural bodies of water or moist soil is not expected to be an important fate process.

Potential for mobility in soil is very high (Koc between 0 and 50).

Partition coefficient (Koc): < 1 Estimated.

Inorganic corrosion inhibitor

No relevant data found.

13. DISPOSAL CONSIDERATIONS

Disposal methods: DO NOT DUMP INTO ANY SEWERS, ON THE GROUND, OR INTO ANY BODY OF WATER. All disposal practices must be in compliance with all Federal, State/Provincial and local laws and regulations. Regulations may vary in different locations. Waste characterizations and compliance with applicable laws are the responsibility solely of the waste generator. AS YOUR SUPPLIER, WE HAVE NO CONTROL OVER THE MANAGEMENT PRACTICES OR MANUFACTURING PROCESSES OF PARTIES HANDLING OR USING THIS MATERIAL. THE INFORMATION PRESENTED HERE PERTAINS ONLY TO THE PRODUCT AS SHIPPED IN ITS INTENDED CONDITION AS DESCRIBED IN MSDS SECTION: Composition Information. FOR

UNUSED & UNCONTAMINATED PRODUCT, the preferred options include sending to a licensed, permitted: Recycler. Reclaimer. Incinerator or other thermal destruction device.

14. TRANSPORT INFORMATION

TDG

Not regulated for transport

Classification for SEA transport (IMO-IMDG):

	Not regulated for transport
Transport in bulk according to Annex I or II of MARPOL 73/78 and the IBC or IGC Code	Consult IMO regulations before transporting ocean bulk

Classification for AIR transport (IATA/ICAO):

Not regulated for transport

This information is not intended to convey all specific regulatory or operational requirements/information relating to this product. Transportation classifications may vary by container volume and may be influenced by regional or country variations in regulations. Additional transportation system information can be obtained through an authorized sales or customer service representative. It is the responsibility of the transporting organization to follow all applicable laws, regulations and rules relating to the transportation of the material.

15. REGULATORY INFORMATION

Canadian Domestic Substances List (DSL)

All substances contained in this product are listed on the Canadian Domestic Substances List (DSL) or are not required to be listed.

16. OTHER INFORMATION

Hazard Rating System

NFPA

Health	Flammability	Instability
0	1	0

Revision

Identification Number: 11045208 / A208 / Issue Date: 12/16/2019 / Version: 8.0

Most recent revision(s) are noted by the bold, double bars in left-hand margin throughout this document.

Legend

CA ON OEL	Canada. Ontario OELs
TWA	8-hr TWA
TWAEV	time-weighted average exposure value
US WEEL	USA. Workplace Environmental Exposure Levels (WEEL)

Full text of other abbreviations

AICS - Australian Inventory of Chemical Substances; ASTM - American Society for the Testing of Materials; bw - Body weight; CERCLA - Comprehensive Environmental Response, Compensation, and Liability Act; CMR - Carcinogen, Mutagen or Reproductive Toxicant; DIN - Standard of the German Institute for Standardisation; DOT - Department of Transportation; DSL - Domestic Substances List (Canada); ECx - Concentration associated with x% response; EHS - Extremely Hazardous Substance; ELx - Loading rate associated with x% response; EmS - Emergency Schedule; ENCS - Existing and New Chemical Substances (Japan); ErCx - Concentration associated with x% growth rate response; ERG - Emergency Response Guide; GHS - Globally Harmonized System; GLP - Good Laboratory Practice; HMIS - Hazardous Materials Identification System; IARC - International Agency for Research on Cancer; IATA - International Air Transport Association; IBC - International Code for the Construction and Equipment of Ships carrying Dangerous Chemicals in Bulk; IC50 - Half maximal inhibitory concentration; ICAO - International Civil Aviation Organization; IECSC - Inventory of Existing Chemical Substances in China; IMDG - International Maritime Dangerous Goods; IMO - International Maritime Organization; ISHL - Industrial Safety and Health Law (Japan); ISO - International Organisation for Standardization; KECI - Korea Existing Chemicals Inventory; LC50 - Lethal Concentration to 50 % of a test population; LD50 - Lethal Dose to 50% of a test population (Median Lethal Dose); MARPOL - International Convention for the Prevention of Pollution from Ships; MSHA - Mine Safety and Health Administration; n.o.s. - Not Otherwise Specified; NFPA - National Fire Protection Association; NO(A)EC - No Observed (Adverse) Effect Concentration; NO(A)EL - No Observed (Adverse) Effect Level; NOELR - No Observable Effect Loading Rate; NTP - National Toxicology Program; NZIoC - New Zealand Inventory of Chemicals; OECD - Organization for Economic Co-operation and Development; OPPTS - Office of Chemical Safety and Pollution Prevention; PBT - Persistent, Bioaccumulative and Toxic substance; PICCS - Philippines Inventory of Chemicals and Chemical Substances; (Q)SAR - (Quantitative) Structure Activity Relationship; RCRA - Resource Conservation and Recovery Act; REACH - Regulation (EC) No 1907/2006 of the European Parliament and of the Council concerning the Registration, Evaluation, Authorisation and Restriction of Chemicals; RQ - Reportable Quantity; SADT - Self-Accelerating Decomposition Temperature; SARA - Superfund Amendments and Reauthorization Act; SDS - Safety Data Sheet; TCSI - Taiwan Chemical Substance Inventory; TSCA - Toxic Substances Control Act (United States); UN - United Nations; UNRTDG - United Nations Recommendations on the Transport of Dangerous Goods; vPvB - Very Persistent and Very Bioaccumulative

Information Source and References

This SDS is prepared by Product Regulatory Services and Hazard Communications Groups from information supplied by internal references within our company.

DOW CHEMICAL CANADA ULC urges each customer or recipient of this (M)SDS to study it carefully and consult appropriate expertise, as necessary or appropriate, to become aware of and understand the data contained in this (M)SDS and any hazards associated with the product. The information herein is provided in good faith and believed to be accurate as of the effective date shown above. However, no warranty, express or implied, is given. Regulatory requirements are subject to change and may differ between various locations. It is the buyer's/user's responsibility to ensure that his

activities comply with all federal, state, provincial or local laws. The information presented here pertains only to the product as shipped. Since conditions for use of the product are not under the control of the manufacturer, it is the buyer's/user's duty to determine the conditions necessary for the safe use of this product. Due to the proliferation of sources for information such as manufacturer-specific (M)SDSs, we are not and cannot be responsible for (M)SDSs obtained from any source other than ourselves. If you have obtained an (M)SDS from another source or if you are not sure that the (M)SDS you have is current, please contact us for the most current version.
CA