



Heat

Dry

Thaw

Cure

OPERATOR MANUAL

Central Mobile Enclosure
1800 HHP Series



DRYAIR MANUFACTURING CORP.
PO BOX 126, 400 SERVICE ROAD
ST. BRIEUX, SK S0K 3V0
CANADA
www.dryair.ca

Tel: 1 (306) 275-4848
Toll-Free: 1 (888) 750-1700
Fax: 1 (306) 275-4664
Email: service@dryair.ca



Table of Contents

- 1. Warranty Policies & Claim Procedures..... 1-5
 - Warranty Policies 1-5
 - Basic Warranty Policy 1-5
 - Extended Warranty Policy..... 1-5
 - Heat Exchanger 1-5
 - Exceptions to the Warranty Policies 1-5
 - Owner Obligations..... 1-6
 - Manufacturer Obligations..... 1-6
 - Warranty Claim Procedure 1-6
- 2. Safety Concerns 2-1
 - General Safety Guidelines 2-1
 - Water Heater Module..... 2-2
 - Heat Transfer Fluid 2-2
 - Fluid Handling Precautions 2-2
 - First Aid Measures..... 2-2
 - Trailer Safety 2-2
- 3. Introduction 3-1
 - Components 3-1
 - 1800 Hydro Heat (1.8 HHP) Enclosure 3-1
 - Plate Heat Exchangers 3-1
 - Extension Reservoir Assembly 3-2
 - Mixing/Booster Pump..... 3-2
 - Optional Remote Manifold..... 3-2
 - Fluid Circulation Lines 3-2
 - Insulated Line Jackets..... 3-3
 - Portable Heat Exchangers 3-3
 - Plate Heat Exchanger 3-3
 - D-CAN Desiccant Dehumidifier System..... 3-4
 - How the System Works 3-5
- 4. Setup 4-1
 - Lifting the Unit..... 4-1
 - Prerequisites 4-1
 - Tie-Down..... 4-1
 - Prerequisites 4-2
 - Required Safety Clearances 4-3
 - Elevation Concerns 4-3
 - Electrical Requirements & Connection..... 4-3
 - Heat Transfer Fluid “HTF” 4-5
 - Heat Transfer Fluid Specifications..... 4-5
 - Circulation lines (not supplied)..... 4-6
 - Fuel/Gas 4-6
 - Diesel/Light Oil..... 4-6
 - Propane Gas..... 4-6
 - Natural Gas..... 4-6
 - Burner Identification 4-7
 - Burner Removal..... 4-7



Burner Installation.....	4-8
Ambient Air Temperature.....	4-9
5. Operation	5-1
Purging air from the HTF circulation system.....	5-1
Before Firing the System	5-2
Heat Module Probe Location	5-2
Cold Start Procedure	5-3
Temperate Start Procedure.....	5-3
Control settings	5-4
Initiate Firing.....	5-4
Purging Air from the Diesel/Light Oil Fuel System.....	5-4
Purging Air from the Natural Gas/Propane Fuel System	5-4
Adding HTF to system.....	5-5
Startup for Diesel/Light Oil Burner:	5-6
Gas Connection and Start-up for Propane Burner:.....	5-9
Gas Connection and Start-up for Natural Gas Burner.....	5-11
Shut-Down Procedure.....	5-13
5-13	
6. Troubleshooting	6-1
No Power at Outgoing Side of Water Heater Toggle Switch.....	6-1
No Power through the Low Water Cut-off.....	6-1
No Power at Flow Switch.....	6-1
No Power at Outgoing Side of High Limit Switches	6-2
No Power at L-Fire	6-2
No Power at Hi-Fire.....	6-2
7. Maintenance	7-1
Daily Checklist.....	7-1
Seasonal Checklist	7-1
Heat Transfer Fluid "HTF"	7-2
8. Appendix	8-1
Important Certification & Operational Information	8-1
Certification & Heater Specifications	8-2
Electrical Schematics	8-3
Trailer Electrical Schematics	8-4
Heat Transfer Fluid Preheater Information.....	8-6
Material Safety Data Sheets	8-8

Table of Figures

Figure 1 - Safety Decals	2-1
Figure 2 – 1800 Hydro Heat Pro Enclosure	3-1
Figure 3 - Plate Heat Exchangers.....	3-1
Figure 4 - Extended Reservoir.....	3-2
Figure 5 - Mixing/Booster Pump	3-2
Figure 6 - Optional Remote Manifold.....	3-2
Figure 7 - Circulation Lines	3-2
Figure 8 - Hose Loop Length	3-3
Figure 9 - Insulated Line Jackets	3-3
Figure 10 - Portable Heat Exchangers.....	3-3
Figure 11 - Plate Heat Exchanger Unit.....	3-3
Figure 12 - D-CAN 30 Dessicant Dehumidifier	3-4
Figure 13 - How the System Works.....	3-5
Figure 14 - Lifting Points.....	4-1
Figure 15 - Lifting Sling Angles	4-1
Figure 16 - Lifting Frame (Part #018-906197)	4-2
Figure 17 - Sling 4x12' (Part# 017-905675)	4-2
Figure 18 - Tie-Down Points	4-2
Figure 19 - Top-View Clearances	4-3
Figure 20 - Side-View Clearance	4-3
Figure 21 - Electrical Hookup (230V AC).....	4-4
Figure 22 - Glycol/Water Mixture Chart	4-5
Figure 23 – Heat Module.....	4-6
Figure 24 - Natural Gas Connection.....	4-6
Figure 25 - Propane Connection.....	4-6
Figure 26 - Diesel/Light Oil Burner	4-7
Figure 27 - Propane Gas Burner	4-7
Figure 28 - Natural Gas Burner	4-7
Figure 29 - Electrical Connection	4-7
Figure 30 - Fuel Supply and Return Lines	4-8
Figure 31 - Fuel Supply and Return Lines	4-8
Figure 32 - Propane Gas/Natural Gas Burner Connections	4-8
Figure 33 - Riello Burner Tube & Mounting Bracket.....	4-8
Figure 34 - Combustion Head Adjustment.....	4-9
Figure 35 – Heat Modules.....	5-1
Figure 36- Control Panel	5-2
Figure 37 Pump connections	5-5
Figure 38 Fill Hose	5-5
Figure 39 - Removing Burner Drawer Assembly	5-6
Figure 40 - Burner Nozzle	5-6
Figure 41 - Ignition Electrode Setting	5-6
Figure 42 - Turbulator Setting.....	5-7
Figure 43 - Air Shutter	5-7
Figure 44 - Fuel Pressure Adjustment	5-7
Figure 45 - Servo Motor	5-9



Figure 46 - Servo Motor	5-11
Figure 48 - Glycol Return Valve	5-13
Figure 47 - Heat Module Circulation Valves.....	5-13
Figure 49 - Heat Exchanger Breakdown	7-2
Figure 50 - Non-Pressure Vessel Decal	8-1
Figure 51 - Water Heater Data & Serial Plate	8-2
Figure 52 – 1800 Hydro Heat Pro Electrical Schematic	8-3
Figure 53 – 1800 Hydro Heat Pro heat pump module wiring.....	8-4
Figure 54 - Close-up View of Trailer Hook-up	8-4
Figure 55 - Trailer Wiring Schematic.....	8-5
Figure 56 - HTF Preheater.....	8-6



1. Warranty Policies & Claim Procedures

DryAir MANUFACTURING CORP. (referred to within as DryAir) warrants its new, unused equipment to be free of defects in material and workmanship at the time of delivery to the original retail purchaser.

Warranty Policies

Basic Warranty Policy

- DryAir will repair or replace, at its option, without charge, any defective part of the equipment for a period of twelve (12) months from delivery to the first retail purchaser, F.O.B St. Brieux, SK., Canada.
- Any parts that are covered by an extended warranty published by DryAir are an exception to the Basic Warranty policy and are to be warrantied as per the details of the Extended Warranty Policy.
- Labour is covered as per DryAir flat labour rate.
- The Warranty Policy, terms, and conditions may change from time to time without prior notice.
- Warranty terms and conditions are transferable in the event of the sale to a second owner.
- Replacement parts will be warrantied for 90 days from the repair date. Bill of sale must accompany the warranty claim.
- The terms of this Warranty Policy are subject to provincial and state legislation. DryAir reserves the right to make modifications in accordance with provincial and state legislation without prior notice or obligation.

Extended Warranty Policy

Heat Exchanger

- An extended warranty is available on the heat exchanger unit of the water heater assembly. The available warranty for a part, under the extended warranty policy, is prorated by 20% per year.
- Shipment date is the date to be used for the commencement of the warranty period.
- Coverage schedule

Year 1 - 100%

Year 2 - 80%

Year 3 - 60%

Year 4 - 40%

Year 5 - 20%

Exceptions to the Warranty Policies

- Under no circumstance shall the owner be entitled to recover costs for incidental, special, or consequential damages such as, but not limited to loss of profit or revenue, other commercial losses, inconvenience and/or replacement equipment rental cost.
- Maintenance, repair, or service items not related to warrantable defects.
- Loss or damage during shipping.
- Failure resulting from lack of or improper maintenance.
- Damage caused by operator abuse, negligence, or improper operation.
- Damage resulting from improper voltage supply.
- Damage from improper installation. Installation done by other than the manufacturer.
- Non-defective items replaced at the request of the customer.
- Damage due to accidents.
- Damage resulting from improper fuel supply (i.e. pressure or contamination).
- Damage resulting from cracked or broken lines occurring during transport.
- Damage resulting from use of inadequate or improper fluids (i.e. Glycol or oil).
- Mileage is not covered.
- Glycol is considered a consumable and will not be covered under the warranty policy.



- Generators carry their own warranty coverage through their own manufacturers. Please refer generator issues to the OEM. Contact information may be found in the Service & Operators Manual under Optional Equipment.

Owner Obligations

- It is the responsibility of the owner, at the owner's expense, to transport the equipment to the service facility of an authorized DryAir distributor/dealer or alternately to reimburse the distributor/dealer, for any traveling expenses incurred in fulfilling this warranty.
- The terms of this Warranty Policy are subject to provincial and state legislation. DryAir reserves the right to make modifications in accordance with provincial and state legislation without prior notice or obligation.
- It is the responsibility of the owner to read, understand and implement the maintenance, safety and operational guidelines as laid out in the Operation and Maintenance Guide.
- All parts are to be tagged with warranty claim number and shipped prepaid to DryAir within 30 days.

Manufacturer Obligations

- DryAir reserves the right to continually improve the product's parts or specifications at any time without notice or obligation.
- The terms of this Warranty Policy are subject to provincial and state legislation. DryAir reserves the right to make modifications in accordance with provincial and state legislation without prior notice or obligation.

Warranty Claim Procedure

- All warranty credits must be processed with the DryAir Warranty Claim Form.
- All warranty parts, unless otherwise specified, are to be returned to DryAir along with a completed Warranty Claim Form.

Note: Prior to returning warranty parts, please call for an authorization number and shipping instructions from the Warranty department in Canada.

Location of Warranty Depots:

USA

DryAir Manufacturing Corp.
410 Douglas Road, Box 264
Bradner, OH 43406
Ph. 1 (888) 750-1700

Canada

DryAir Manufacturing Corp.
400 Service Road, Box 126
St. Brieux, SK S0K 3V0
Ph. 1 (888) 750-1700

- Each warranty claim should only refer to one Serial or Production Schedule numbered unit.
- Warranty parts are to be tagged with warranty claim number.
- When claiming for warranty labour, the allowable warranty labour rate will be \$85.00/hour. The factory reserves the right to adjust the number of hours claimed where deemed necessary.
- The factory may at times specify allowable labour for certain warranty procedures.
- Mileage and travel time to/from the customer are not eligible for warranty credit.
- Freight charges for warranty parts are not eligible for warranty credit.
- Labour flat rates for component changes:
 - Electrical Components - 0.5hr
 - Relays
 - Switches
 - Thermostats
 - Breakers
 - Electric Motor Changes - 1hr
 - Hose Reel



- Plumbing Components - 1hr
 - Flow Reverser
 - Flow Switch
 - Valves
- Glycol Pump Changes - 2hrs

Note: Other labour charges will be at the discretion of DryAir.

2. Safety Concerns

General Safety Guidelines

- Make certain that the operator reads and understands all the information in this manual.
- All unauthorized people must be kept away from the equipment while in operation.
- Maintain instructional and safety decals. Replace damaged decals. (Figure 1)
- All guards must be in place when the equipment is in operation.



Figure 1 - Safety Decals



Water Heater Module

CAUTION! The water heater is a heating appliance.

- Observe all posted warnings and cautions when dealing with any heating appliance.
- Keep children and pets away from all piping and fuel accessories.
- While the system is operating the water heater housing panels must be kept closed - This prevents drafts from affecting water heater operation.
- The DryAir Hydro Heat Pro is rated for use in an ambient air temperature of 20°C (68°F) down to 40°C(-40°F).

The 1.8 million Btu Hydro Heat Pro combines the heating power of an efficient DryAir water heater and two fluid to fluid, plate heat exchangers into one ready to move, trailer package. The system uses three pumps, one for the water heater’s heating fluid circuit (food grade glycol) and one for each of the two-plate heat exchanger output loops, which can be sized to meet various flow and pressure requirements.

In many jurisdictions the use of a pressurized boiler or a hydronic heater with a rating of over 1 million Btu results in increased permitting, inspections and staff with boiler tickets. Using a non-pressurized water heater system with two 900,000 Btu burners in the 1800 Hydro Heat Pro minimizes these overhead costs and timeline which can significantly influence the success of your heating project.

In the DryAir system, the heat transfer around your site is almost entirely managed by low-pressure Heat Transfer Fluid lines.

Heat Transfer Fluid

Follow the following precautions and measures when working with “heat transfer fluid” (“DOWFROST* HTF” & “BOSS CHILL PG”).

Fluid Handling Precautions

- Ventilation Good general ventilation should be sufficient for most conditions.
- Respiratory protection. No respiratory protection should be needed.
- Skin protection For brief contact, no precautions other than clean, body-covering clothing should be needed.
..... Use impervious gloves when prolonged or frequently repeated contact should occur.
- Eye protection Use safety glasses.

First Aid Measures

- Eyes Flush eyes with plenty of water.
- Skin Wash off in flowing water or shower.
- Ingestion Induce vomiting if large amounts are ingested.
..... Consult medical personnel.
- Inhalation Remove to fresh air if effects occur.
..... Consult a physician.
- Note to Physician No specific antidote.
..... Supportive care.
..... Treatment based on judgment of the physician in response to reactions of the patient.

For complete “heat transfer fluid” information, refer to the Material Safety Data Sheets for “Dowfrost HTF” & “Boss Chill PG” included with the manuals package.

Trailer Safety

DryAir trailers are equipped with torsion single or tandem axles with electric brakes on each axle. It is necessary to tow units with tandem axles as parallel as possible to the road to ensure equal loading on each axle. The tow vehicle must be equipped with a brake controller for the electric brakes to function.



The tow vehicle operator is responsible for the following:

- Ensure that all the tires are inflated to the manufacturer's specifications.
- Check the tire tread on all tires for indications of wear or misalignment.
- Test the signal lights, brake lights, and park lights for proper operation.
- Ensure that all tire lug nuts are properly torqued to 120 ft-lb.
- The operator must make sure that the brakes are functioning correctly.
- Before towing, the operator of the tow vehicle must ensure that the trailer is hooked correctly to the tow vehicle including:
 - Safety chains
 - Breakaway cable
 - Electrical connection (lights, brakes)
 - Ensuring that the trailer tongue is properly fastened to the trailer frame.

Note: *Trailer must be towed level so as not to overload either axle, otherwise axle damage can occur.*

3. Introduction

Components

1800 Hydro Heat (1.8 HHP) Enclosure

- A compact and portable design.
- Easy access from rear and side doors.
- Automatic temperature control and fuel usage which responds to worksite demands.
- Low pressure, atmospherically vented circulation system.
- No special boiler certification is required to operate the system.
- A central heat module control center which monitors and controls system operations.
- A multi-light system operation feature for easy water heater troubleshooting.
- Patented Combustion Environment Control System preheats the air and fuel used for combustion.

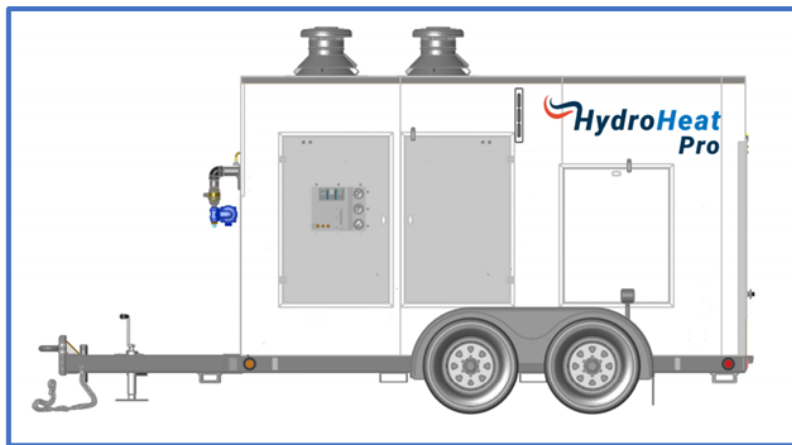

Figure 2 – 1800 Hydro Heat Pro Enclosure

Plate Heat Exchangers

- Dual on-board plate heat exchanger/pump packages. One dedicated for heating process water (boiler tie-ins etc.) and one dedicated to potable water applications.
- Each heat exchanger/pump package is equipped with an easily cleanable “Filter Ball” to protect the plate from debris large enough to plug the passages. The filter ball is a last line of defense to protect the heat exchanger and is not intended to act as a filter to remove large quantities of debris.
- If large quantities of debris are present in the fluid being heated, installation of a much larger capacity strainer 20-40 mesh is recommended on the pump inlet line.



Figure 3 - Plate Heat Exchangers

Accessories

Extension Reservoir Assembly

(Not required with the 900-HCP, already equipped with back flow prevention. See Elevation Concerns, page 4-9.)

The Extended Reservoir Tank is required in scenarios when “portable heat exchangers” are higher than the top level of the glycol reservoir tank. If the Extended Reservoir tank is not used, the following can occur:

- Insufficient Fluid in the System**
 Fluid can drain back to the heat transfer reservoir tank from the over-elevated fluid lines when the pump is shut off. The heat transfer reservoir tank will show adequate fluid, but when the pump is started extra fluid will be required to recharge the over-elevated fluid lines and portable heat exchangers and the system will then have insufficient fluid in the reservoir.
- Fluid Overflow**
 If fluid is added to maintain proper fluid levels while the pump is running, overflow at the reservoir tank will occur when the pump is shut off. This would occur because of the drain back from the over-elevated fluid lines.



Figure 4 - Extended Reservoir

Mixing/Booster Pump

The multifunctional mixing/booster ensures maximum flexibility in the use of this system.

- Tempering mode supplies lower temperature fluid for concrete cure and radiant floor heat applications, eliminating the need to reduce the water heater operating temperatures below safe operating ranges.
- When operating in booster mode the system can increase flow rates or function as a pumping station to increase pumping distances by over 300ft per station.
- The system also allows for dual-temperature control. High temperature fluid can be provided to portable heat exchangers, along with a lower temperature fluid for concrete cure and radiant floor heat applications.



Figure 5 - Mixing/Booster Pump

Note: Disengage Flow Reverser when using this accessory.

Optional Remote Manifold

The multifunctional mixing/booster ensures maximum flexibility in the use of this system.

- Allows for additional distribution and/or separation between the central heating trailer and the manifold.



Figure 6 - Optional Remote Manifold

Fluid Circulation Lines

Fluid circulation lines are designed to endure the toughest work site environments. Portable distribution manifolds connected to the primary circulation system redistribute the heat transfer fluid through secondary lines. All fluid circulation components come with isolation valves and quick couplers, ensuring quick set up, start up, and quick disassembly when the job is done. DryAir provides a full range of hoses, adapters, and manifolds for handling and distributing HTF.



Figure 7 - Circulation Lines

The circulation line heat exchangers are the perfect solution for:

- Heating and/or thawing cold or frozen ground.
- Frost prevention.
- Concrete curing and heating in subzero environments.
- Hose loops are typically 500ft in length with maximum of 1,000ft achieved by connecting two hoses together. Refer to the Components, Hose Reel section of the Operator Manual to verify hose length for your unit.

This system can be applied to all types of concrete applications. Circulation line heat exchangers can be secured directly against the surface of the concrete or concrete forms.

Alternatively, an expendable circulation line can be incorporated into the concrete structure during the pour. This allows the slab floor to continue being heated, to provide radiant floor heat during construction.

Insulated Line Jackets

Insulated circulation line jackets are also available. These insulated jackets will prevent exposed circulation line heat loss in extreme subzero conditions.

Portable Heat Exchangers

Portable heat exchangers are the ideal way to heat and/or dry enclosed structures. Their compact and mobile design allows them to be positioned where required on the job site. The efficient fan/coil design provides a high rate of heat transfer. High volume fans then deliver this heat evenly throughout a large area. The clean, low relative humidity heat delivery minimizes energy costs by eliminating the need to draw in fresh outside air. With this system, you just reheat warm internal air, rather than heating cold external air.

Note: Disengage Flow Reverser when using this accessory.

Plate Heat Exchanger

The plate heat exchanger module uses a stacked parallel flat plate braised heat exchanger. This creates two separate and isolated fluid loops. In glycol-glycol situations it can extend the range of the HTF distribution. In other situations, it can be used to transmit heat energy from the glycol to another fluid. The plate heat exchangers combined with a central heating module can be used:

- To extend the effective range and lengths of the primary distribution lines.
- In a multi-story application to extend the vertical range of the primary distribution lines.
- In an HTF to liquid heating application, such as heating a swimming pool or other volume of water (or other low-viscosity non-corrosive liquid).

Note: Disengage Flow Reverser when using this accessory

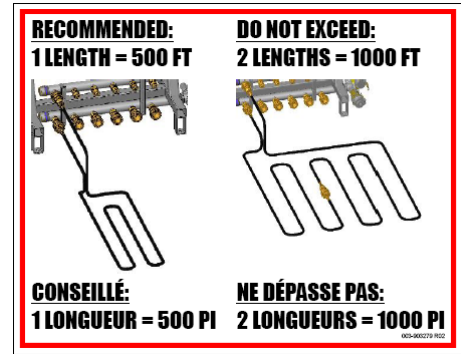

Figure 8 - Hose Loop Length



Figure 9 - Insulated Line Jackets



Figure 10 - Portable Heat Exchangers



Figure 11 - Plate Heat Exchanger Unit



D-CAN Desiccant Dehumidifier System

The D-CAN 30 delivers all of the benefits of desiccant drying with reduced electrical requirements, lower operating temperatures, and fuel savings compared to other traditional Diesel/Electric systems.

- At 3,000 CFM the D-CAN 30 is capable of removing close to 300 gallons of water per day.
- There are no combustion by-products to vent from the D-CAN 30 granting operators the added flexibility of being able to place the unit inside or outside the structure for easier setup.
- Only two 115V/20A circuits are needed to run the blowers: no high voltage cords means increased safety on the site.
- Turn the desiccant wheel off and the D-CAN 30 offers the added flexibility of operating as a 300,000 BTU heat exchanger to provide temporary heat to the structure.



Figure 12 - D-CAN 30 Desiccant Dehumidifier

How the System Works

The central heating module uses a low-pressure, open-fluid loop distribution system with an atmospherically vented fluid reservoir. The central heating module warms the heat transfer fluid. This heated fluid is pumped through an isolated circuit in the Process Water and/or the Potable Water heat exchange module(s). The Process Water Pump and/or the Potable Water Pump circulate fluids to be heated from and to the source through a second isolated circuit in the heat exchange module(s).

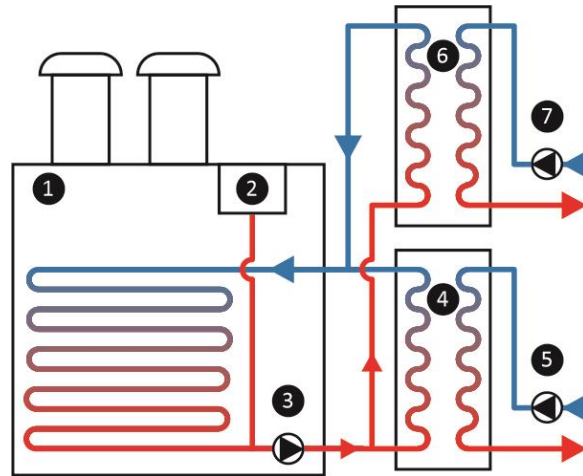

1. Water Heater Module
2. Water Heater Fluid Reservoir
3. Water Heater Circulation Pump
4. Process Water Module
5. Process Water Circulation Pump
6. Potable Water Module
7. Potable Water Circulation Pump

Figure 13 - How the System Works

4. Setup

The positioning of all the system components on the site will be influenced by a number of factors. Please read all of the "Setup" section before beginning. Be sure to observe all local electrical codes and fire regulations when positioning the central heating module.

Lifting the Unit

Prerequisites

- Properly rated lifting equipment (crane or hoist). The 1800 Hydro Heat Pro can weigh in excess of 9,000lbs (4,083kgs).
- Inspect lift components for damage and defects. If any of the components are damaged or have defects, replace affected components before proceeding.
- Ensure "018-906197 PKG LIFT FRAME 1.8 HHP" is installed and all fasteners are tight.
- Torque $\frac{1}{2}$ " fasteners to 80 ft-lbs and $\frac{5}{8}$ " fasteners to 150 ft-lbs.
- Attach "017-905675 SLING 4X12' 10,700 LB @ 60 DEGREES" lift sling.
- Ensure unit is off and all electrical power and circulation lines are disconnected.
- All doors and access covers are closed and secured.

Warning! Crushing hazard. You may be crushed if the lifting devices fail.

- Never stand under or get onto the machine while it is being lifted or moved.
- Use only designated lift points to lift the machine.

Tie-Down

Using proper Tie-Down points will allow for safe and easy transport of your unit.

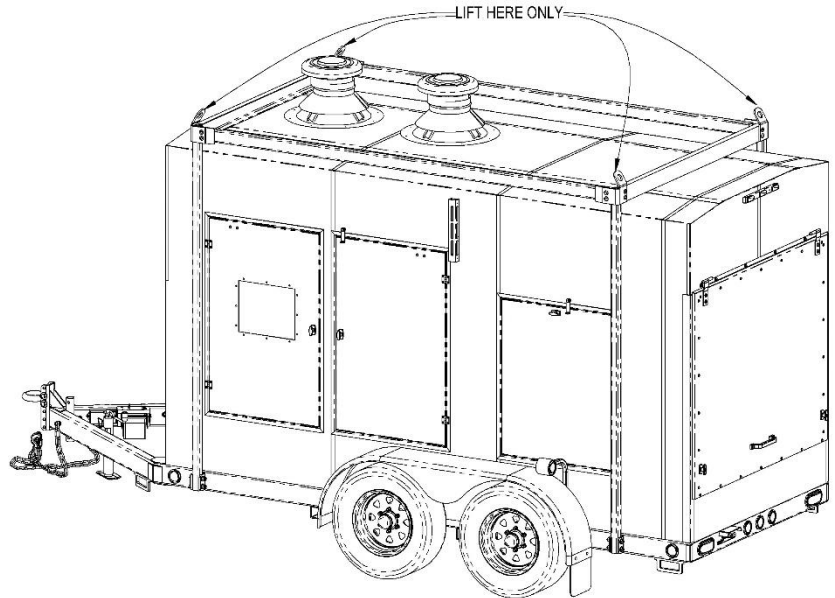

Figure 14 - Lifting Points

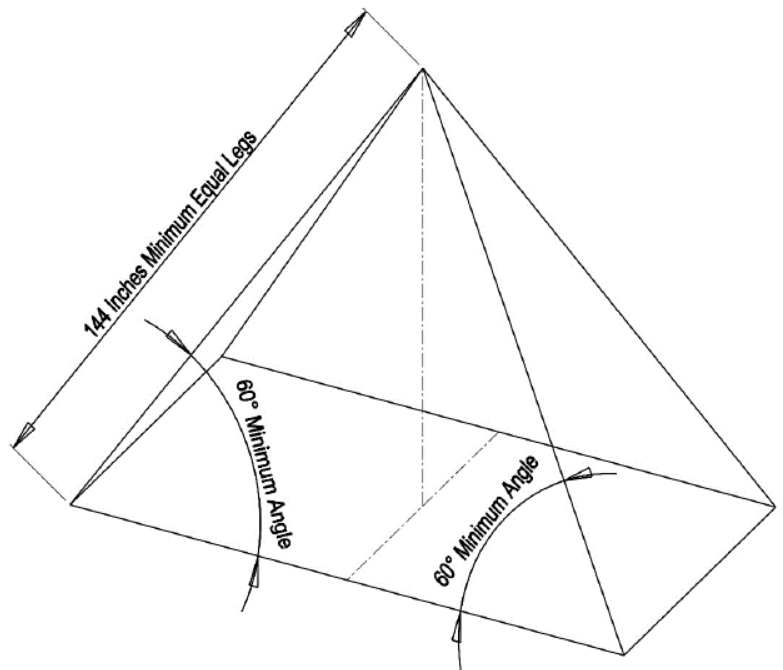

Figure 15 - Lifting Sling Angles

Prerequisites

- Properly rated chains or straps. A fully loaded 1800 Hydro Heat Pro can weigh in excess of 9,000lbs (4,083kgs).
- All doors and access covers closed and secured.

Note: Use only approved tie-down points.

1. After loading the unit onto a deck, deploy the jack. With the assistance of the jack, position substantial blocking under the front most crossmember of the trailer so that the unit is slightly lower front to back. Remove tension from the jack to ensure the jack is not damaged by compression resulting from tightening chains or straps.
2. Using the rear most tie-down points, through both eyes, strap or chain the unit at a rearward angle. Initially apply only enough tension to keep the unit from rolling. Using the front tie down points, through both eyes, strap or chain the unit, at a forward angle providing both downward pressure on the blocking and slight forward pressure.
3. Alternately tighten rear straps or chains as required to secure the unit for transport.
4. Check chain or strap tension after the first 30 mi (50 km) of travel and every 100mi (160km) thereafter.

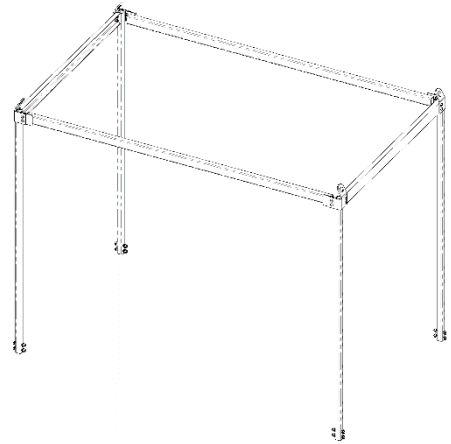

Figure 16 - Lifting Frame (Part #018-906197)



Figure 17 - Sling 4x12' (Part# 017-905675)

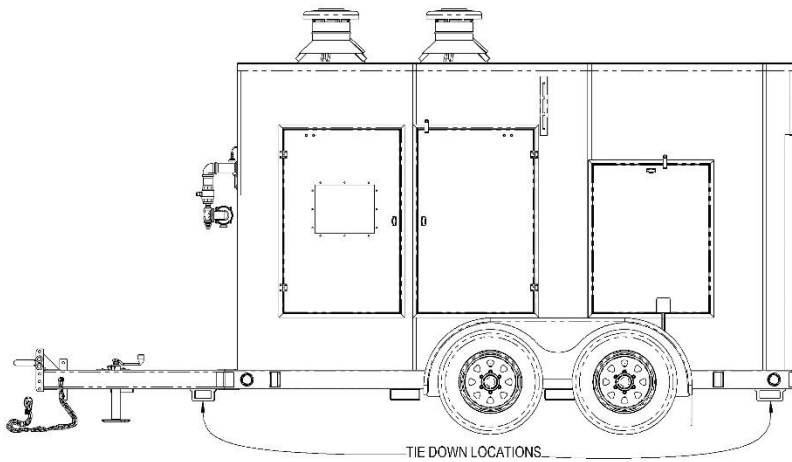

Figure 18 - Tie-Down Points

Required Safety Clearances

1800 Hydro Heat Pro is a heating appliance, therefore safe heat and exhaust clearances must be observed from combustible materials and for service access.

- Maintain 24" (61 cm) of clearance on all sides of the unit (*Figure 19*).
- Maintain 36" (91 cm) of clearance on all sides of the flue pipes and chimney caps (*Figure 20*).

Elevation Concerns

With the integrated plate heat exchanger design, heating fluids that are circulated in a closed loop to a level of 50ft above the 1800 Hydro Heat Pro is possible. Applications greater than 50ft (15m) can be attained, contact DryAir service for assistance.

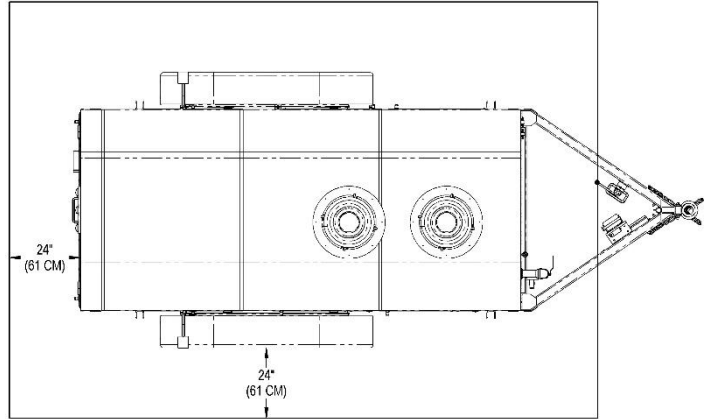

Figure 19 - Top-View Clearances

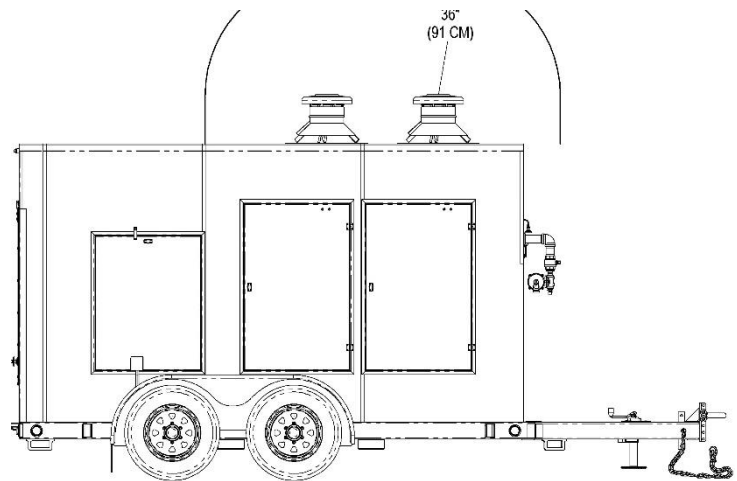

Figure 20 - Side-View Clearance

Electrical Requirements & Connection

When determining the “central mobile enclosure” location on site, consider setting up near the electrical power supply.

- The main feed wiring must be adequately sized to carry the minimum ampacity shown on the water heater cabinet’s rating label. All electrical connections, connectors and wire must be CSA/UL compliant and installed according to local laws and codes.
- Before making any electrical connections, be sure that the electric power supply is “Off”.

Electrical Connection

- The 1800 Hydro Heat Pro requires 115/230V AC Power. The module is factory wired so that the only connections to be made are two 4-wire 120/240V AC service outlets.
- 2 X 30A (230V) of power is needed to operate the 1800 Hydro Heat Pro with all accessories. Electrical connections to main are to be two NEMA L14-30R’s connecting to the recessed L14-30P’s, located on the front of the unit.
- The main feed wiring must be adequately sized to carry the minimum ampacity shown on the water heater cabinet’s rating label.
- All electrical connections, connectors and wire must be CSA/UL approved, and installed according to local laws and codes.
- A 4-wire hookup is required for all systems to work properly. Warranty is void if the wiring hookup is not done correctly (Figure 21).

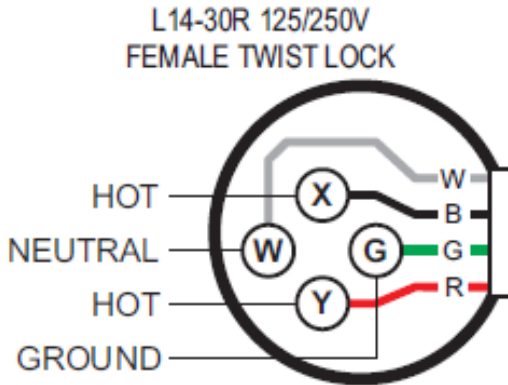

Figure 21 - Electrical Hookup (230V AC)

Note: Warranty is void if the wiring hookup is not done correctly.



Heat Transfer Fluid “HTF”

CAUTION! At no time should you use automobile antifreeze in your system. The use of automobile antifreeze will void your warranty.

- The heat transfer fluid “HTF” level should show no more than ¼ on the gauge (cold fluid) at start-up. As the “HTF” warms to operating temperature, fluid expansion will raise the level to ½ or ¾ on the gauge (depending on the total volume of fluid in the circulation system).

Heat Transfer Fluid Specifications

- The system is shipped with pre-mixed “HTF”, made up of 50% “Dowfrost ® HTF” or “Boss Chill PG” and 50% water*, by weight – freeze protection down to -28°F (-33°C).
- The “glycol/water mixture chart” below will provide you with more information on the proper mixture for your area.
- “Dowfrost ® HTF” or “Boss Chill PG” must be used. The pure “Dowfrost ® HTF” or “Boss Chill PG” heat transfer fluid used in the system is made of a blend of 95-97% Propylene glycol, <5% Dipotassium phosphate and deionized water (see Safety Concerns section – MSDS sheets) for additional information.
- Soft water with a pH level (#7) must be used.

Percent Propylene Glycol		Freezing Point	
By Mass	By Volume	°F	°C
0.0	0.0	32.0	0.0
10.0	9.6	26.1	-3.2
20.0	19.4	17.9	-7.8
30.0	29.4	6.7	-14.0
40.0	39.6	-8.1	-22.3
50.0	49.9	-28.9	-33.8
60.0	60.0	-54.9	-48.3

Figure 22 - Glycol/Water Mixture Chart

CAUTION! Whenever coupling or uncoupling quick couplers, make sure that the isolation valves are closed, and the pump is off. Failure to do so may put you at risk of injury from eye and/or skin exposure to hot glycol.

Circulation lines (not supplied).

Note: It is recommended to flush and drain the intended heat transfer module with potable water prior to connecting circulation lines. This is to ensure previous fluids heated by the module are purged preventing cross contamination with the fluid intended to be heated. Check and if necessary clean the “Filter Ball” screen.

- Circulation lines must be 2” ID min. for distances up to 100’ (200’ total combined hose length).
- Distances beyond 100’ require 2-1/2” ID min circulation lines.
- If possible, position the circulation lines out of high traffic areas.
- Connect the circulation lines to the “supply” and “return” camlock couplers on the appropriate heat transfer module.

Note: Heat module pumps are primarily circulation pumps and not intended for suction/lift. Fluid to be heated must be supplied to the pump as part of a circulation loop capable of 85 gpm@0psi. to prevent heat module pump from cavitating.



Figure 23 – Heat Module

Fuel/Gas

See “Burner Setup – Burner Identification” – below for burner type.

Diesel/Light Oil

- Only clean #1 or #2 diesel fuel or light heating oil is suitable for use in the system.
- The “central heating module” does not come equipped with its own tank, so therefore an auxiliary fuel tank and hoses are required. It is recommended to filter fuel from auxiliary fuel tank before entering CHU.
- The central heating module comes equipped with Supply and Return fuel quick couplers. Both Supply and Return lines must be connected to tank for proper operation.
- The fuel system utilizes a two-pipe system to ensure efficient fuel supply to the burner.

* Contact your local fuel supplier to inform them of the requirements.

Propane Gas

- A supply of “Propane Vapor” should be connected to the inlet of the secondary regulator at a pressure of 10 PSI MAX.

* Provide your local Propane supplier with BTUH input requirements to ensure an adequate volume of vaporized propane even in the coldest ambient conditions.

Natural Gas

- A supply of “Natural Gas” should be connected to the manual gas train supply valve at a pressure of approximately 12-14” W.C.
- If equipped, remove secondary regulator (for propane use) and store with Propane burner prior to connecting Natural Gas supply.

* Provide your local Natural Gas Utility Company with BTUH input and pressure requirements to ensure adequate volume of gas at the correct pressure range.



Connection



Connection

Burner Identification

Riello’s identification label is located on the top flange of the burner’s main chassis plate and identifies if the burner is for use with “Diesel/Light Oil”, “Natural Gas” or “Propane Gas”.

White vinyl labels are also located on both the burners’ main chassis plate and to the top of the burner cover hood:

- Black Lettering = Diesel/Light Oil Burner (Figure 26)
- Red Lettering = Propane Gas Burner (Figure 27)
- Blue Lettering = Natural Gas Burner (Figure 28)

If the installed burners are the correct fuel type to be used, proceed to the applicable startup section.

If burners of a different fuel type are required, replace both burners with the correct fuel type before proceeding to the applicable startup section. The existing burners must then be removed before the alternate burners can be installed. The 1800 Hydro Heat Pro is equipped with dedicated storage for optional alternate burners located on the passenger side of the enclosure. If alternate burners are required and not provided, they must be obtained from your DryAir Manufacturing Corp. distributor.

Burner Removal

To remove an existing **Riello Model 40-F20 Diesel/Light Oil Burner**, use the following sequence:

1. Make certain that the power supply to the water heater is disconnected.
2. Disconnect the electrical connection to the burner by unplugging the 6-pin Molex connector. This connection is on a cord by the right side of the burner. (Figure 29)
3. Disconnect the combustion air duct by loosening the gear clamp-band.
4. Disconnect the fuel supply hose and fuel return hose by uncoupling the quick connections on the side of the burner. The loose supply and return hose ends should be coupled together (to keep connections clean) and pushed aside of the way inside the cabinet. (Figure 31)
5. Remove 2 nuts from top of burner tube bracket. (Figure 33)
6. Pull burner toward you and away from the mounting bracket. (Figure 33)
7. Remove the gas hose plug to accommodate the propane/natural gas burner union.

To remove an existing **Riello Model 40-G900 Propane Gas Burner** or **Natural Gas Burner**, use the following sequence:



Figure 26 - Diesel/Light Oil Burner



Figure 27 - Propane Gas Burner

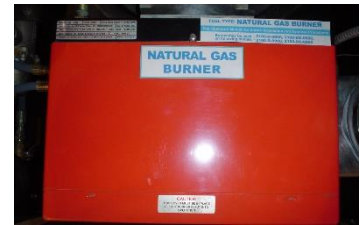

Figure 28 - Natural Gas Burner



Figure 29 - Electrical Connection

1. Make certain that power supply and gas supply are shut off and disconnected from the water heater.
2. Disconnect the electrical connection to the burner by unplugging the 6-pin Molex connector and the 4-pin Molex connector. This connection is on a cord by the right side of the burner. (Figure 29)
3. Disconnect the combustion air duct by loosening the gear clamp-band. (Figure 32)
4. Close off the manual gas train valve. (Figure 32)
5. Use 2 wrenches to loosen and disconnect the gas supply hose from the gas train to burner. (Figure 32)
6. Remove 2 nuts from top of burner tube bracket. (Figure 33)
7. Pull burner toward you and away from the mounting bracket.
8. Replace the gas train plug to prevent a blockage or debris. (Figure 32)

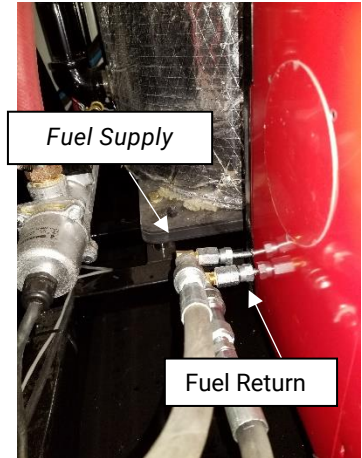

Figure 30 - Fuel Supply and Return Lines

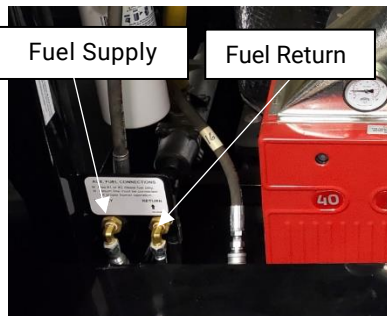

Figure 31 - Fuel Supply and Return Lines

Burner Installation

To install an alternate **Riello Model 40-F20 Diesel/Light Oil Burner:**

1. Insert burner into the mounting bracket.
2. Install 2 nuts at top of burner tube bracket. (Figure 33)
3. Connect the fuel supply hose and fuel return hose by coupling them to the quick connections on the side of the burner. (Figure 31)

4. Make the electrical connection to the burner by plugging in the 6-pin sMolex connectors. (Figure 29)

To install an alternate **Riello Model 40-G900 Propane Gas Burner or Natural Gas Burner:**

1. Insert burner into the mounting bracket.
2. Install 2 nuts at top of burner tube bracket. (Figure 33)
3. Connect gas supply hose from gas train to burner. Use 2 wrenches to tighten. (Figure 32)
4. Open the manual gas train valve.
5. Remove locking nut and swing burner chassis away to expose the combustion head adjustment mechanism. Loosen Allen screw and move the head assembly until the rear edge of the air tube coincides with the desired number setting. (Figure 34)
 - a. Setting for model "1800 Hydro Heat Pro" (natural gas or propane) should be 5.0 (all the way in).
6. Lock off the setting, swing the burner closed and replace the locking nut.
7. Connect combustion air duct and tighten the gear clamp-band.
8. Make the electrical connection to the burner by plugging in the 6-pin Molex connectors. The 4-pin Molex connector must also be connected, as this controls the gas train. (Figure 29)

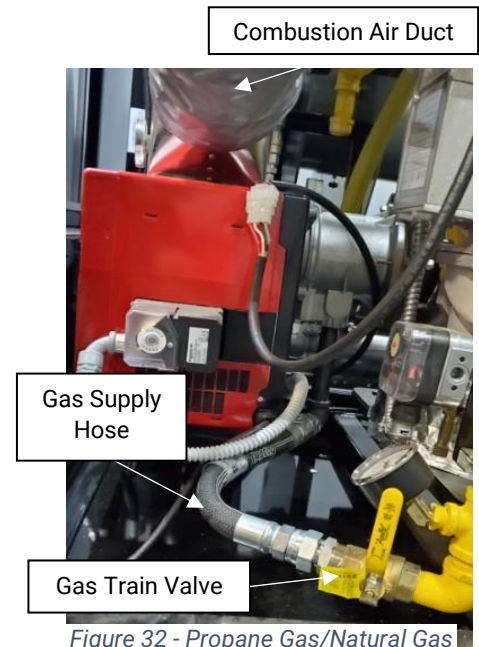

Figure 32 - Propane Gas/Natural Gas Burner Connections

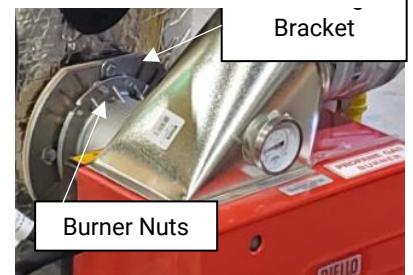

Figure 33 - Riello Burner Tube & Mounting Bracket

9. Fuel Supply Notes

COMBUSTION HEAD ADJUSTMENTS

To set combustion head, loosen the Allen screw (A) and move the elbow (B) so that the rear edge of the air tube (C) coincides with the set point number (D). Retighten the Allen screw (A).

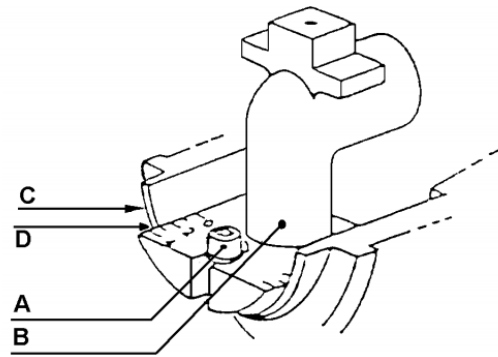

Figure 34 - Combustion Head Adjustment

The installation must conform to the requirements of the authority having jurisdiction or, in the absence of such requirements, to the National Fuel Gas Code, ANSI Z223.1/NFPA 54, and/or Natural Gas and Propane Installation Code, CAN/CSA B149.1.

When testing the customer supplied gas piping (outside the 1800 Hydro Heat Pro enclosure) the water heaters and its individual shutoff valves must be disconnected from the gas supply piping system during any pressure testing of that system at test pressures in excess of ½ psi (3.5 kPa). The water heaters must be isolated from the gas supply piping system by closing its individual manual shutoff valve during any pressure testing of the gas supply piping system at test pressures equal to or less than ½ psi (3.5 kPa).

Note: The water heater and its gas connection must be leak tested before placing the water heater in operation.

CAUTION! Should overheating occur or the gas supply fails to shut off, do not turn off or disconnect the electrical supply to the pump. Instead, shut off the gas supply at a location external to the appliance.

Ambient Air Temperature

- When operating the Hydro Heat Pro in temperatures above 40°F (5°C), be sure to open the vent door when the unit is running.
- Internal fans circulate air through the unit to keep the components cool.



5. Operation

Purging air from the HTF circulation system

Note: All valves between the heat modules and the water heater should be open when the unit is not in use. This is to prevent over pressurization of heat exchange modules. Expansion/contraction caused by trapped fluid can potentially damage heat exchange modules. Heater return valve must remain open under all circumstances and is only intended for ease of maintenance.

Important: Start the Cold circuit first (heat module pump). Once flow in the cold circuit is proven, Start the Hot circuit (water heater). For shutdown turn off the water heater (hot circuit) first and allow temperatures to stabilize before stopping the heat module (cold circuit) pump.

- Close Heater supply valve to unused heat module to protect unused heat module and maximize flow to active heat module. Failure to close valve will cause over heating of the unused heat module potentially causing damage and reducing maximum heat output of active heat module.
- Verify that the HTF level gauge shows approximately $\frac{1}{4}$ to $\frac{1}{2}$ full.
- Verify that the circulation lines are connected in a way that allows looping (circulation) of the fluid to be heated. Verify that the “supply” and “return” valves at both ends of the circulation lines are in the “open” position.
- Toggle the switch on the module’s temperature control toggle switch (fig - 36) to the “on” position, the temperature control should now have power. The water heater and pump switch on the main panel must be on to receive power. Dial the temperature to the appropriate temperature, check with secondary controller by holding the “Press for set point” button. This will open the flow to the heat module as the controller regulates the glycol to allow the water to heat to a consistent temperature. The flow is controlled by the controller sending power to the actuator on the module glycol inlet.
- Toggle the active heat module pump switch to the “On” (up) position and run the pump. Observe pressure gauge on the heat module pump. Steady pressure above 15 psi will indicate flow has been established and air has been purged from the circulation loop to be heated. If pump pressure is not established or fails to stabilize toggle pump switch off (down) and rectify before proceeding.
- **Note:** Heat module pumps are primarily circulation pumps and not intended for suction/lift. Fluid to be heated must be supplied to the pump as part of a circulation loop capable of 85 gpm@0psi. to prevent heat module pump from cavitating.

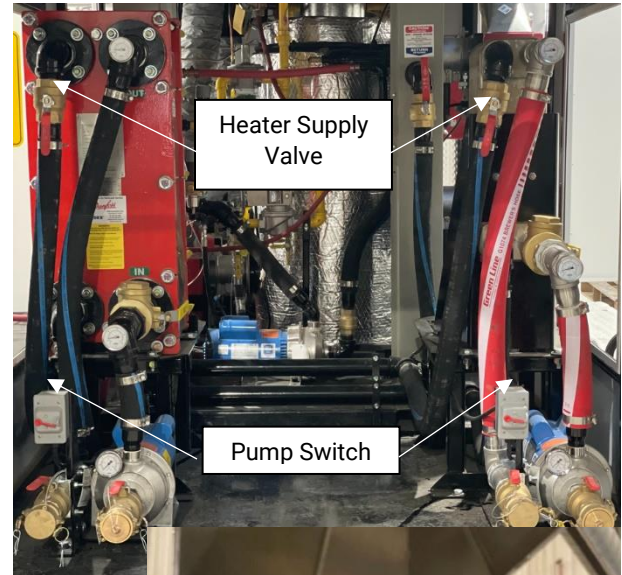

Figure 36 – Heat Module Temperature Control

- Once flow has been established in the heat module pump circuit, it is safe to proceed.
- Air in the HTF circuit is vented from the system by means of an open line from the tops of the water heater modules to the atmospherically vented HTF reservoir.
- Toggle the water heater pump switch to the “On” (up) position and run the pump. This will release the air from the system.
- Monitor the HTF sight glass gauge and make sure that the HTF level stays between ¼ & ½ full at all times during this process.
- Note that there may be a certain amount of air in the system. HTF levels may change as air is displaced from the system. Add HTF to maintain ¼ to ½ levels when the fluid is cold.
- When the air is eliminated, the water heater “System Pressure” gauge (Figure) will hold at a steady reading between 15 PSI to 40 PSI.



Figure 37- Control Panel

Before Firing the System

- Verify that the power supply is correct and that the electrical hook up is as specified in “Setup”.
- Verify that the water heater is being supplied with the same fuel type as indicated on the burner.
- Verify that the fuel line valves are in the Open/Normal positions.
- Verify (for gas operation) that the correct gas pressure is supplied and both low pressure gas switches have been reset.
- Verify that the heat transfer fluid level gauge shows approximately ¼ full.
- Verify the power is on to the heat module temperature control.

Heat Module Probe Location

- There are two locations the probe for the temperature controllers on the heat module can be placed.
- To change the probe location, the probe and the temperature gauge will swap places.
- The sensor on the water outlet of the heating module better suits applications with a constant cold water source and heated water is needed at a temperature out of the module.
- The sensor on the water inlet better suits applications where a tank or a closed loop is being heated as the outgoing liquid temp will not be the same as the entire system. Once the system is circulating at temperature, the system will maintain that temp.

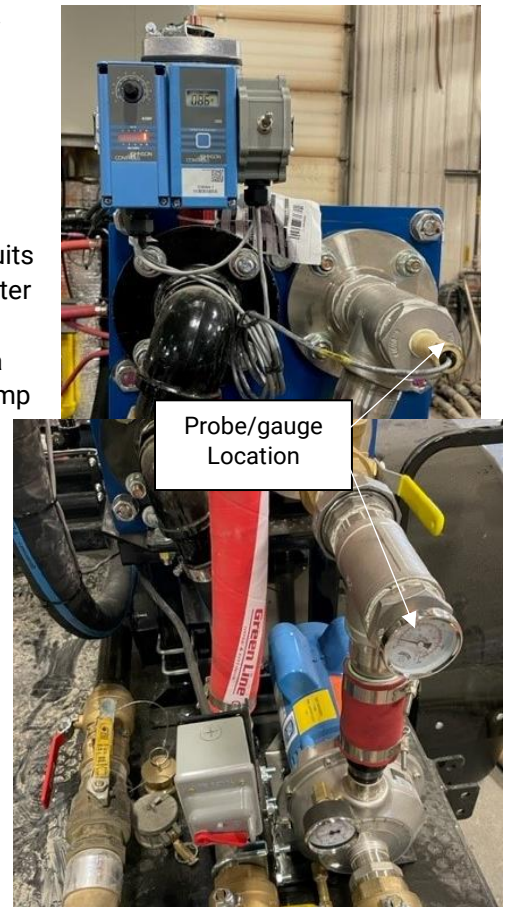



Cold Start Procedure

The system has a patented, built-in electric HTF pre-heater, which will heat the HTF in the heat exchanger without the burner being turned on. This device is unique to DryAir equipment. It is not always necessary to use this device, but it will make the unit start more smoothly and reduce maintenance costs associated with "cold starts". To utilize the HTF preheater, follow the procedure below.

This procedure is recommended if the ambient outdoor air temperature is lower than 50°F (10° C). Consider initiating this process 10 minutes prior to firing the system.

In 0°F (-18° C) conditions, this process will take longer.

- Plug in power supply.
- Confirm that the pump switch and the water heater switch are in the "Off" (down) position.
- Position all breakers to the "On" (up) position. This will automatically energize the electric "cold start" circulation heater.
- Wait until the supply temperature gauge reads above 40° F (10° C). The time required for the heat transfer fluid in the heat exchanger to reach this temperature will depend on the outdoor ambient air temperature.
- Proceed with the "Temperate Start Procedure".

Note: Length of time required for supply temperature to rise above 40° F (4° C) is dependent on outdoor ambient air temperature and environmental conditions. Unit can be left in "Pre-Heat" mode indefinitely without damage and as such can be placed in "Pre-Heat" mode as soon as power is available. Pre-Heat can be used in all ambient temperatures. Step 1 of equipment set up can be connecting power to the water heater and initiating cold start procedure (pre-heat). While setting up accessories the unit will have ample time to reach desired temperatures ensuring trouble free operation.

Temperate Start Procedure

You can proceed with this procedure when:

- a) The ambient outdoor air temperature is above 32° F (0° C) or
- b) The recommended "cold start procedure" has been initiated for 10 minutes if between 32° F (0° C) to 0° F (-18° C) or
- c) The recommended "cold start procedure" has been completed if below 0° F (-18° C).



Control settings

- Set the Aquastat at 180°F (82°C).

Initiate Firing

- Verify that the “Pump Switch” is in the “ON” position.
- Toggle the “Water Heater Switch” to the “ON” position.
- The burner will proceed through its firing sequence.
-

Purging Air from the Diesel/Light Oil Fuel System

If the burner does not fire, the fuel system may need to be purged of air.

- Confirm that there is an adequate fuel supply.
- Toggle the water heater switch to the “Off” (down) position.
- Open all manual valves in the fuel system.
- Confirm that the pump switch is in the “On” (up) position.
- Toggle the water heater switch to the “On” (up) position.
- Depress the reset button. This will activate the fuel pump & burner firing sequence.
- When the fuel system is primed, the fuel pressure gauge will show a steady reading and the water heater should attempt to ignite.

Note: The reset process on Diesel/Light Oil burners can be tried up to six times, at the most. If the water heater does not fire, see the accompanying “Water Heater Module - Service Manual” or “Riello Burner Installation Manual” for information and/or contact DryAir Technical Support 1 (888) 750-1700.

Purging Air from the Natural Gas/Propane Fuel System

If the burner does not fire, the fuel system may need to be purged of air.

- Confirm that there is adequate gas supply pressure.
- Open all manual valves in the fuel system.
- Confirm that the low-pressure and high-pressure gas switches have been reset.
- Confirm that the pump switch is in the “On” (up) position.
- Toggle the water heater switch to the “On” (up) position.
- Depress the reset button. This will activate the burner firing sequence.
- When the fuel system is free of air water heater should attempt to light.
- If the burner fails to ignite, repeat the reset process as required.
- If the water heater does not fire, contact DryAir Technical Support 1 (888) 750-1700.

Adding HTF to system

Verify that the power supply is correct and the electrical hook up is as specified in "Setup".

- Ensure all breakers are in the "On" position.
- Remove fill/drain hose plug from the Fill/Drain hose.
- Connect the Fill/Drain extension hose to the Fill/Drain hose
- Submerge the fill/drain hose extension into the bottom of the barrel/pail or jug or pre-mixed HTF (See "Setup" for HTF specifications).
- Turn the pump supply ball valve to the "Closed" position.
- Toggle the pump switch to the "On" (up) position.
- Turn the fill/drain ball valve to the "Open" position.
- Once the pump switch is in the "On" position, the pump will commence to draw the HTF into the system. By watching the HTF level gauge, continue to fill the system until the HTF level gauge shown is 1/2 full.

CAUTION! Caution must be taken when approaching the 1/2 full mark as it could take 2-3 seconds to register the actual level once pumping has ceased.

- In the case of an overfull situation, do the following:
- Toggle the pump switch to the "Off" (down) position
- Turn the pump supply ball valve to the "Open" position.
- Open the fill/drain ball valve. Gravity will immediately drain the HTF out of the system through the fill/ drain hose. The fill/drain hose should be submerged into a barrel/ pail or jug with sufficient room for the HTF
- Once the desired amount of HTF has been attained and the HTF level gauge is showing half full, turn the fill/drain ball valve to the "Closed" position.



Figure 36 Pump connections

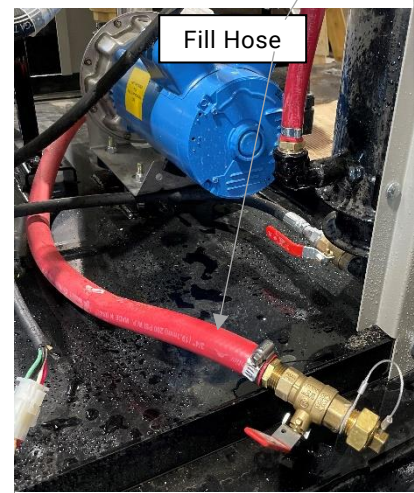

Figure 37 Fill Hose

Startup for Diesel/Light Oil Burner:

Note: The following steps must be performed by "Qualified Personnel" only. Contact your local fuel supplier to inform them of requirements. Only clean, #1 or #2 diesel fuel or light heating oil is suitable for use in this system. These are factory settings, based on standard elevation. Adjustments must be made for high elevation.

1. Remove burner hood.
2. To remove the drawer assembly:
 - Loosen screw (Figure 38 - 3), then unplug control box (Figure 38 - 1), by carefully pulling it back and then up.
 - Remove the air tube cover plate (Figure 38 - 5) by loosening the two retaining screws (Figure 38 - 4).
 - Loosen screw (Figure 38 - 2) and the fuel supply line connection then slide the complete drawer assembly out of the combustion head as shown.
3. Remove the nozzle adapter (Figure 39 - 2) from the drawer assembly by loosening the screw (Figure 39 - 2).
4. Check the nozzle to ensure correct size and type. If wrong, replace the nozzle with one of the correct sizes and types listed below. Nozzles should be replaced after 5,000 hours of service due to gradual erosion of the orifice from high pressure flow.
 - Model 2100-DG-0900 nozzle = 5.00 x 60°B
5. Replace the nozzle adapter into the drawer assembly and re-source the retaining screw.
6. Check the position of the ignition electrodes. Refer to Figure 40 for correct alignment. Adjust if necessary. These dimensions must be observed and verified.

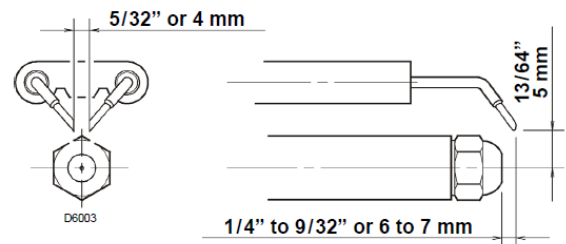
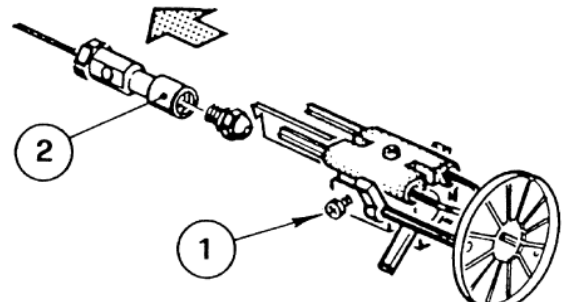
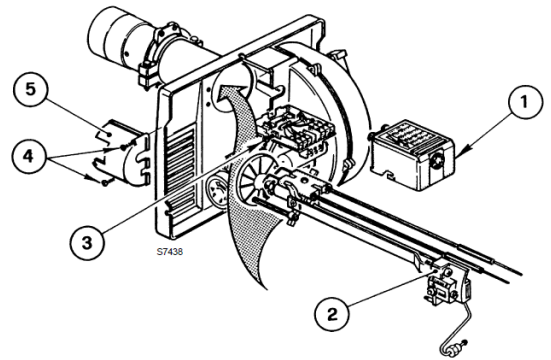
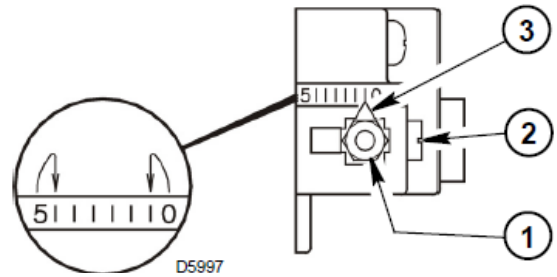

Figure 40 - Ignition Electrode Setting

7. To set the turbulator adjustment assembly:
 - o Loosen nut (Figure 41 – 1) and turn screw (Figure 41 – 2) until index marker is aligned with the correct index number. Re-tighten the retaining nut (Figure 41 – 1).
 - Note: Zero and five are scale indicators only. From left to right the first line is 5 and the last line 0.
 - o Correct turbulator settings are:
 - Model 2100-DG-0900 = 4.0



8. Insert the drawer assembly back into the burner tube. Replace the control box and cover plate by reversing procedure described in 2.
9. Connect power supply to the water heater and establish flow of heat-transfer-fluid by turning on the circulating pump's toggle switch, located on the control panel. Open supply and return isolation valves.
10. Initiate a try for ignition by turning on the water heater toggle switch located on the control panel. The burner will go through a pre-purge cycle before trying for ignition. Due to air in the fuel line, you may have to re-initiate the ignition cycle multiple times, by pressing and holding the burner reset button for at least 10 seconds. Once all air is eliminated, the burner should light. The burner will run on low for about ten seconds before shifting to high fire.

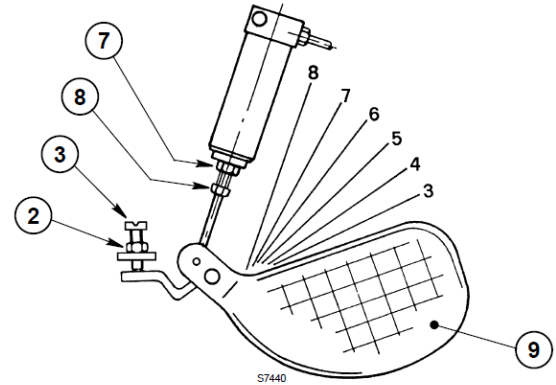

Figure 42 - Air Shutter

Note: If the diesel/light oil burner fails to ignite after several attempts, there may be air in the fuel system. To purge the air from the fuel system – see “**Error! Reference source not found.** - REF_Ref50029477 \h * MERGEFORMAT **Error! Reference source not found.**” section of the Operator Manual.

11. To set the burner's air shutter and fuel pressure (Refer to Figure 42 and Figure 43).
 - While the burner is firing on **low**, loosen retaining nut (2) and turn the adjusting screw (3) until the top of the air shutter (9) is correctly positioned. Hold adjusting screw in position and secure by tightening the retaining nut. Preliminary settings for low fire are:
 - o Model 2100-DG-0900 = 3.0
 - Fuel pressure for **low fire** is factory set to 100 PSI for all models.
 - While the burner is firing on **high**, set fuel pressure by turning the pressure regulator adjustment screw. Fuel pressure gauge is provided to monitor this adjustment. Fuel pressure settings for **high fire** are:
 - o Model 2100-DG-0900 = 145 psi
 - While the burner is firing on **high**, loosen retaining nut and turn the bolt in a counterclockwise direction until about 3/4" of thread is visible. Position the air shutter so the top of the air shutter is aligned with the proper index line. Hold the shutter in the position and turn the adjusting bolt clockwise until a resistance is met. Preliminary air shutter setting for **high fire** are:

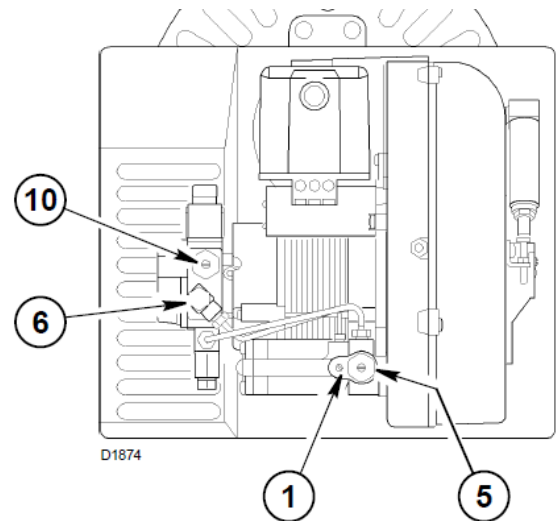

Figure 43 - Fuel Pressure Adjustment



- Model 2100-DG-0900 = 8.0

12. Using a good quality Smoke Spot Tester and Flue Gas Analyzer, take flue gas sample readings at the test port in the flue pipe above the cabinet. Fine tune the readings by adjusting the burner’s air shutter, to achieve acceptable efficiency and emission levels. Final readings must be taken with the burner cover in place and the combustion air duct connected. **Note:** *This step is essential for clean, efficient combustion.*

Acceptable levels are:

2100-DG-1800		
	Summer Fuel	Winter Fuel
FT (Flue Temp)	600°F to 650°F	575°F to 625°F
O ₂	<u>3.2</u> % ± 0.5%	<u>4.3</u> % ± 0.5%
CO	Less than <u>25</u> ppm	Less than <u>25</u> ppm
EFF	Greater than <u>80</u> %	Greater than <u>80</u> %
CO ₂	<u>13</u> % ± 0.5%	<u>12.5</u> % ± 0.5%
EX/A	<u>20</u> % ± 3%	<u>24</u> % ± 3%

Gas Connection and Start-up for Propane Burner:

Note: The following steps must be performed by “Qualified Personnel” only. All permit processes and codes must be followed as administered by the local authority having jurisdiction. Provide your local propane supplier with BTUH input requirements to ensure an adequate volume of vaporized propane even in the coldest ambient conditions. These are factory settings, based on standard elevation. Adjustments must be made for high elevation.

1. If the water heater was already equipped for propane, it should have a secondary regulator installed on the outside of the cabinet as indicated. If propane burners are being installed as an alternate, the secondary regulator will be stored in the burner storage area and must be installed now. Use only CGA/AGA approved thread sealant when making gas piping connections. The manual gas train supply valve should be closed.
2. A supply of “Propane Vapor” should be connected to the inlet of the secondary regulator at a maximum pressure of 10 PSI. Turn on the gas at the supply tank and soap test all piping joints to ensure no leaks are present. Bleed air from the supply line as far as the regulator. Allow 5 minutes for purged gas to dissipate from the area.
3. Open manual gas valve.
4. Servo motor is factory set:
 - Model 2100-DG-0900: ST1=30, ST0=0, ST2=70, N3=40, N5=10

This controls air gate and valve opening sequence & timing and should only be adjusted by knowledgeable personnel with DryAir Service consultation.



Figure 44 - Servo Motor

5. CSD-1 code gas trains have a low-gas pressure switch and a high gas-pressure switch.
Settings for the various models are:
 - Model 2100-DG-0900 = Low = 1.0" W.C. and High = 6.0" W.C.
6. Open the manual gas train supply valve and adjust the secondary regulator until a static reading of 11" W.C. is achieved at the gas supply pressure gauge.
7. Connect power supply to the water heater and establish flow of heat-transfer-fluid by turning on the circulating pump’s toggle switch, located on the control panel. Open supply and return isolation valves.
8. Reset low-gas pressure switch. Initiate a try for ignition by turning on the water heater toggle switch located on the control panel. The burner will go through a pre-purge cycle (approximately one minute) before trying for ignition. Due to air in the gas train, you may have to re-initiate the ignition cycle multiple times, by pressing and holding the burner reset button for at least 10 seconds. Once all air is eliminated, the burner should light.
9. Set the preliminary manifold gas pressure, while the burner is firing, by adjusting the main gas train pressure regulator to achieve a reading of:
 - Model 2100-DG-0900 = 5.20" W.C.

Pressure adjustment can be monitored by observing the manifold gas pressure gauge. The pressure should hold steady.



Note: These pressure settings are given as a starting reference only. Current ambient temperature, wind conditions and atmospheric pressure will all have an effect on actual gas input. The only way to verify actual gas input is to meter the flow of gas to the unit while it is firing. Then gas pressure adjustments can be made to more accurately fine-tune the gas input.

- 10. Soap test gas connections to be certain there are no leaks present.
- 11. Using a good quality Flue Gas Analyzer, take flue gas sample readings at the test port in the flue pipe above the cabinet. Fine tune the readings by adjusting the burner’s air shutter, to achieve acceptable efficiency and emission levels. Final readings must be taken with the burner cover in place and the combustion air duct connected.

Note: This step is essential for clean, efficient combustion.

Acceptable levels are:

2100-DG-1800	
Propane	
FT (Flue Temp)	550°F to 650°F
O ₂	3.3% ± 0.5%
CO	Less than 50 ppm
EFF	Greater than 80%
CO ₂	Less than 12.1%
EX/A	17% ± 2%

Gas Connection and Start-up for Natural Gas Burner

Note: This sequence must be performed by "Qualified Personnel" only. All permit processes and codes must be followed as administered by the local authority having jurisdiction. Provide your local Natural Gas Utility Company with BTUH input and pressure requirements, to ensure an adequate volume of gas at the correct pressure range. These are factory settings, based on standard elevation. Adjustments must be made for high elevation.

1. If the water heater was previously equipped for propane, it may have a secondary regulator installed on the outside of the cabinet as indicated, which **must be removed** now. The removed secondary regulator can be stored in the burner storage area. Close the manual gas train supply valve.
2. Natural gas supply should be connected to the manual gas train supply valve at a pressure of approximately 12 – 14" W.C. Use only CGA/AGA approved thread sealant when making gas piping connections. Turn on the gas at the supply meter, and soap test all piping joints to ensure no leaks are present. Bleed air from the supply line as far as the manual gas train supply valve. Allow 5 minutes for purged gas to dissipate from the area.
3. Open manual gas valve.
4. Servo motor is factory set:
 - Model 2100-DG-0900 ST1=20, ST0=0, ST2=70, N3=40, N5=10

This controls air gate and valve opening sequence & timing and should only be adjusted by knowledgeable personnel with DryAir Service consultation.



Figure 45 - Servo Motor

5. CSD-1 code gas trains have a low-gas pressure switch and a high gas-pressure switch. Settings for the various models are.
 - Model 2100-DG-0900 = Low = 1.0" W.C. and High = 6.0" W.C.
6. Open the manual gas train supply valve and adjust the metered gas supply pressure until a static reading of 13 - 14" W.C. is achieved at the gas supply pressure gauge.
7. Connect power supply to the water heater and establish flow of heat-transfer-fluid by turning on the circulating pump's toggle switch, located on the control panel. Open the supply and return isolation valves.
8. Reset low-gas pressure switch. Initiate a try for ignition by turning on the water heater toggle switch located on the control panel. The burner will go through a pre-purge cycle (approximately one minute) before trying for ignition. Due to air in the gas train, you may have to re-initiate the ignition cycle multiple times by pressing and holding the burner reset button for at least 10 seconds. Once all air is eliminated, the burner should light.
9. Soap test gas connections to be certain there are no leaks present.
10. Set the preliminary manifold gas pressure, while the burner is firing, by adjusting the main gas train pressure regulator to achieve a reading of:
 - Model 2100-DG-0900 = 4.80" W.C.

Pressure adjustment can be monitored by observing the manifold gas pressure gauge. The



pressure should hold steady.

Note: These pressure settings are given as a starting reference only. Current ambient temperature, wind conditions and atmospheric pressure will all have an effect on actual gas input. The only way to verify actual gas input is to meter the flow of gas to the unit while it is firing. Gas pressure adjustments can then be made to more accurately fine-tune the gas input.

11. Using a good quality Flue Gas Analyzer, take flue gas sample readings at the test port in the flue pipe above the cabinet. Fine tune the readings by adjusting the main gas train pressure regulator to achieve acceptable efficiency and emission levels. Final readings must be taken with the burner cover in place and the combustion air duct connected.

Note: This step is essential for clean, efficient combustion.

Acceptable levels are:

2100-DG-1800	
Natural Gas	
FT (Flue Temp)	550°F to 650°F
O ₂	3% ± 0.5%
CO	Less than 50 ppm
EFF	Greater than 80%
CO ₂	Less than 10.1%
EX/A	17% ± 2%

Shut-Down Procedure

- Toggle the water heater switch to the “Off” position.
- Allow supply temperature to cool down to approximately 100 degrees F.
- Toggle the water heater pump switch to the “Off” position.
- Close fuel or gas shut-off valve.
 - Fuel shut-off valve is at the bottom of the fuel pre-heater.
 - Gas shut-off valve is at the front of the unit (Figure 24,25; 4-6)
- Toggle heat module pumps to the “Off” position.
- Disconnect power from unit.
- Drain heat modules to avoid possibility of freezing.
 - Uncap Kamlocks.
 - Open both, supply and return, circulation valves and let contents drain (Caution: Contents may be hot).
 - Drain pumps with drain valve at the bottom of each pump.
- Once heat modules and pumps are fully drained, recap Kamlocks. Circulation valves and pump drain valve can be left in the open position.
- Ensure Glycol return valve is kept in the open position to protect heat modules.

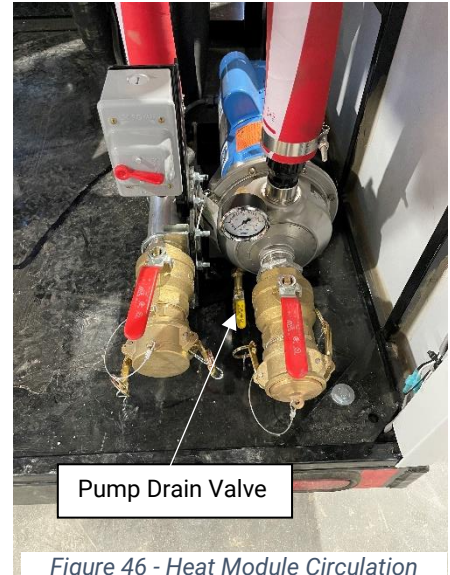

Figure 46 - Heat Module Circulation Valves



Figure 47 - Glycol Return Valve

6. Troubleshooting

- There are 8 troubleshooting/warning lights on the control panel. The upper 6 green troubleshooting lights indicate the status of a sequence of functions while the unit is running. The lower 2 red warning lights indicate low fluid levels.
- When the burner is on, all green lights should be on. Any light that is not illuminated while the burner is on should be considered burnt out.
- The Aquastat and Burner lights will turn ON and OFF as the burner cycles.
- Troubleshoot power issues at the control panel terminal strip. Remove the control panel to expose terminal strip.
- Refer to “Appendix – Electrical Schematic” for terminal locations.



No Power at Outgoing Side of Water Heater Toggle Switch

Check for 120V power between letter N and #1 on the terminal strip. If there is no power check the following:

- Check that the water heater circuit breaker has not been switched off.
- Check that water heater toggle switch has not been turned off.
- Check for power in and out of breaker and toggle switch.
- Check that correct power supply has been connected to the unit. Investigate the power source and be certain that the power characteristics are correct (115/230V, 30 Amp, single phase, 4-conductor, 0’-100’ – 10AWG, over 100’ – 8 AWG).



No Power through the Low Water Cut-off

Check for 120V power between letter N and #2 on the terminal strip. If there is no power check the following:

- Low water situation. Check fluid level in tank and add if necessary.
- Check 24V Relay for 120V power into COM terminal.
- Check 24V Relay for 24V power to the coil.

**LWCO- If LWCO is not working and the tank has fluid, call DryAir for further assistance.*



No Power at Flow Switch

Check for 120V power between letter N and #3 on the terminal strip. If there is no power, then check between N and #2 on the terminal strip. If there is no power, check the following:

- Pump Not Running:
 - Check pump breaker and toggle switch on the control panel.
 - Check for 230V at pump motor. If correct power is confirmed at motor, but pump will not run, replace pump.
- Inadequate Flow:
 - Check that all valves are open in the Fluid Transfer loop. – Filter screen may be plugged. Use flush hose/valve attachment into a bucket, while pump is running, for a quick flush. Eventually the system may have to be drained and the filter screen removed and cleaned by hand. – If fluid-receiving units are closed off, check that the pressure bypass valve is open.
 - When performing “ground thaw” or “concrete cure” application, the use of only one “heat exchanger loop” may result in adequate flow. Utilizing at least two “heat exchanger loops” will provide adequate flow or a short bypass loop can also be incorporated to correct this situation.
 - Air present in the circulation system. Air in the system can cause cavitation in the pump and pressure loss. Refer to “Operation, Purging Air from the System” for air purging instructions.
 - Supply temperature overrun causing vaporization (steam) & pump pressure to be lost. Cavitation will occur in the “Water Heater Heat Exchanger” causing a noticeable bubbling, popping sound. Check the “Overflow Outlet” to confirm presence of fluid vapor. If vaporization is occurring, the Aquastat setting is set too high. Reset the Aquastat to a lower temperature (by 10°F increments) and allow cool-down. When the HTF cools down, the system will regain pump pressure. Allow the



burner to cycle back on and observe to ensure that the vaporization situation does not reoccur. If it does reoccur, reset the Aquastat to a lower temperature until the problem is rectified.

Note: This situation is more likely to occur in a "Low Flow" situation (refer to Operation, Temperate Start Procedure, Control Settings).

- c) Defective Flow Switch:
 - If a) and b) check out good, the flow switch will need to be re-calibrated or replaced.



No Power at Outgoing Side of High Limit Switches.

Check for 120V power between letter N and #4 on the terminal strip. If there is no power check the following:

- a) Manual reset high limit – Check and reset if it has been tripped.
- b) Check switch settings. The automatic high limit should be set 10°F higher than the set point of the aquastat, and the manual reset high limit should be set 10°F higher than the automatic high limit switch.
- c) Determine which high limit switch is defective and replace.



No Power at L-Fire

Check for 120V power between letter N and terminal NO on the Aquastat Staging Module. If there is no power check the following:

- a) Check that the setting on aquastat is at desired operating temperature.
- b) Check well sensor (electric) and verify that it is intact and positioned properly in its well.
- c) If a) and b) check out good, replace both the aquastat and sensor.

Gas Burner Scenario Only

- d) Hi and Low Gas Pressure switches – Check and reset if tripped.
- e) Check that the internal burner fuse is not burned.



No Power at Hi-Fire

Check for 120V power between letter N and #5 on terminal strip. If there is no power check the following:

- a) Check that the setting on aquastat is at desired operating temperature.
- b) Check well sensor (electric) and verify that it is intact and positioned properly in its well.
- c) If a) and b) check out good, replace both the aquastat and sensor.

In NG and PN scenarios the Lo-Fire and Hi-Fire lights will not come on if the HI/LOW pressure switches are tripped.

s
If burner does not start, press reset button on burner. Check for fuel pressure during pre-purge. You may need to reset burner a couple times to purge system. Call DryAir for further assistance.

FOR ADDITIONAL ASSISTANCE CALL DryAir TECHNICAL SUPPORT 1 (888) 750-1700



7. Maintenance

The DryAir system is designed to be a low maintenance system. All system equipment is assembled using extensively tested and certified components. Following these maintenance procedures will ensure the maximum benefit and minimal downtime for the system. The daily maintenance schedule is designed to be a quick system check and ensures a low risk of operating interruptions. Additional supplemental information provided by component manufactures such as the hose reel and is included with each unit. Use the supplemental information for maintenance procedures and frequency as directed.

Daily Checklist

A daily inspection of the water heater cabinet should be performed with attention paid to the following:

Check for Strong Odor of Fuel

- If a leak or the odor of fuel is noticed immediately turn off all power switches and the main fuel supply to the water heater cabinet.
- Ventilate the water heater cabinet.
- Find and correct the leak before turning on any power or trying to relight the water heater.

Check Heat Transfer Fluid "HTF" Level Everyday

- Maintain between $\frac{1}{4}$ and $\frac{3}{4}$ on the heat transfer level gauge when fluid is hot.
- Top up, as necessary.
- For "HTF" specifications, see "Setup, Heat Transfer Fluid, "HTF", Fluid Specifications.
- For "HTF" handling precautions, refer to "Safety Concerns, Material Safety Data Sheet".
- If loss of fluid is excessive check for leaks at all the fittings and connections in the water heater cabinet, as well as the fluid circulation system.

Check the Supply Temperature Gauge

- Verify that the supply temperature gauge is within 10°F of the aquastat setting.

Seasonal Checklist

Fuel (Water Block/Particulate) Filter *(If equipped with diesel burner)*

- The water block/particulate filter should be changed every heating season, or as required.

Hoses

- Periodically check all hoses for damage due to aging, elevated temperatures, over-torqued hose clamps, abrasion, and weathering.
- Replace damaged hoses as required.
- Seasonally check hose clamp torque and adjust accordingly.

Water Heater Heat Exchanger

- Keep the flues in the water heater clean. Soot is a nonconductor of heat; a dirty water heater requires more oil to heat a structure than a clean one. Water heaters can corrode on the fireside. This results from corrosive substances in the fuel and can be difficult to control. Some fuel oils contain substances which cause fireside corrosion. Sulphur, vanadium, and sodium are among the materials that may contribute to this problem. The probability of trouble from this source depends to a large degree on the amount of Sulphur in the fuel and on the care used in cleaning the fireside heating surfaces. This is particularly true when preparing a boiler for a period of idleness. Preventing this problem also depends on keeping the boiler heating surfaces dry when a boiler is out of service.
- The person responsible for water heater maintenance should be certain that the fireside surfaces of the water heaters in his care are thoroughly cleaned at the end of the firing season. He should also

observe the fireside surfaces during the firing season and if signs of corrosion are discovered, a reputable consultant should be contacted.

- The flue pipe and chimney cap should be taken off once a year and thoroughly cleaned of all soot.

Note: Check the gauge panel at regular intervals for any irregular gauge readings.

Heat Exchanger Cleaning Procedure

- Remove the burner from the water heater (Figure 48).
- Remove the plate from the bottom of the water heater (1-2).
- Remove the refractory board from the water heater by reaching into the burner hole and lightly tapping the board with your hand until it drops down (1-3).
- Remove the flue collar (1-4) to expose the burner tubes (1-5).
- Remove all flue baffles (1-6).
- Clean burner tubes with a steel round brush or rag on a piece of rod (1-5).
- Vacuum all debris.

Heat Transfer Fluid "HTF"

- A clean and properly maintained hot water system should not be drained unless there is a possibility of freezing, the boiler has accumulated a considerable amount of sludge or dirt on the water side, or draining is necessary to perform repairs. Very little sludge should accumulate in a water heater where little make-up water is added and where an appropriate water heater water treatment is maintained at proper strength.
- The "HTF" should be tested from year to year for freeze protection and should be strong enough for your area. The "HTF" should be checked with a refractometer. Check the glycol/water mixture chart (see "Setup, Heat Transfer Fluid") for the mixing ratios.
- The "pH level" of the "HTF" requires an annual check to see if the pH level is neutral. The pH level should be at #7. This should be checked with a pH instrument.

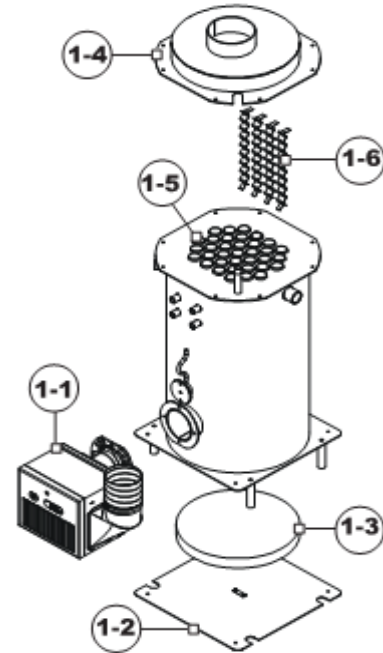

Figure 48 - Heat Exchanger Breakdown

Note: See Setup: Heat Transfer Fluid Specifications; page 4-5; Figure 22 - Glycol/Water Mixture Chart for complete HTF specifications.



Burner

- For burner seasonal maintenance see the “Service Manual”.

Plate Type Heat Exchangers

- For seasonal maintenance see the “Supplemental information” provided by the manufacturer

Servicing Electrical Systems

CAUTION! *Label all wires prior to disconnection when servicing controls. Wiring errors can cause improper and dangerous operation.*

- Verify proper operation after servicing.

8. Appendix

Important Certification & Operational Information

Non-Pressure Vessel

- The unit includes an open atmospherically vented expansion tank
- The expansion tank is integrally connected to the heat-exchanger section of the water heater by means of a permanently open line (no valves).
- The heat exchange section connects to the inlet side of the circulating pump and therefore, only neutral atmospheric pressure is present within the heat exchange section.

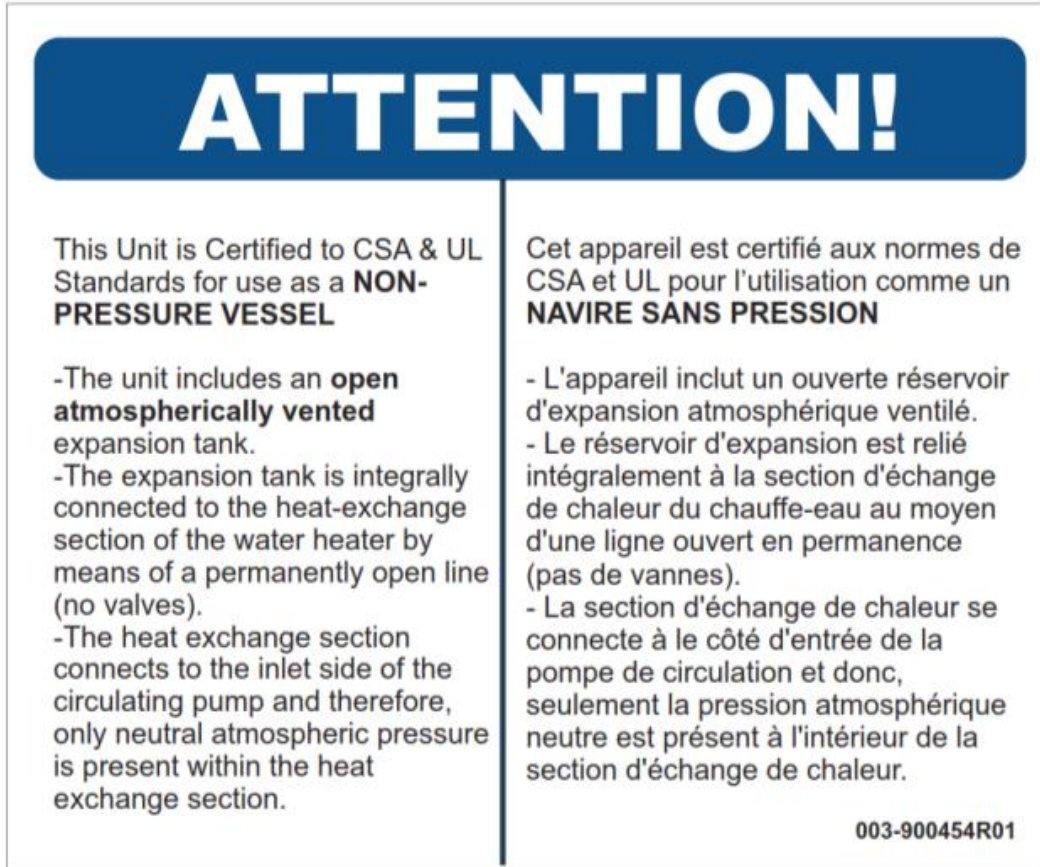

ATTENTION!

This Unit is Certified to CSA & UL Standards for use as a **NON-PRESSURE VESSEL**

- The unit includes an **open atmospherically vented** expansion tank.
- The expansion tank is integrally connected to the heat-exchange section of the water heater by means of a permanently open line (no valves).
- The heat exchange section connects to the inlet side of the circulating pump and therefore, only neutral atmospheric pressure is present within the heat exchange section.

Cet appareil est certifié aux normes de CSA et UL pour l'utilisation comme un **NAVIRE SANS PRESSION**

- L'appareil inclut un ouverte réservoir d'expansion atmosphérique ventilé.
- Le réservoir d'expansion est relié intégralement à la section d'échange de chaleur du chauffe-eau au moyen d'une ligne ouvert en permanence (pas de vannes).
- La section d'échange de chaleur se connecte à le côté d'entrée de la pompe de circulation et donc, seulement la pression atmosphérique neutre est présent à l'intérieur de la section d'échange de chaleur.

003-900454R01

Figure 49 - Non-Pressure Vessel Decal



Certification & Heater Specifications

		P.O. Box 126 400 Service Road St. Brieux, Sk. Canada S0K 3V0		 MADE IN CANADA				
DRYAIR Model:		Reference:						
Serial No.:		Prod. Sched.:						
Main Power		Oil Burner		Natural Gas Burner				
Volts:	240 V(2L,N,G)	Model:	Riello 40-F20		Model:	Riello 40-G900		
Phase:	1	Fuel:	#2 Heating Oil	#1 Heating Oil	Fuel:	Natural Gas		
Hz:	60 HZ	Calorific Value:	140,000 BTU / US Gal.	136,000 BTU / US Gal.	Calorific Value:	1000 BTU/ft ³		
Max. Ampacity	30 A	Output:	BTUH	BTUH	Max. Gas Pressure:	14" W.C.		
Control Voltage	120/24VAC	Fuel Input:	US GPH		Min. Gas Pressure:	12" W.C.		
Min. Circuit Ampacity	A	Pump Pressure:	P.S.I.		Manifold Gas Pressure:	W.C.		
Max. Overcurrent Protection	A				Input Capacity:	BTUH		
					Output Capacity:	BTUH		
		Clearances:						
		Sides	24" (61cm) minimum					
		Flue Pipe	36" (91cm) minimum					
		Floor	0" (0cm) non-combustible					
		Complies to: ANSI Z21.13						
C US								
						003-903389 R02		

Figure 50 - Water Heater Data & Serial Plate

Electrical Schematics

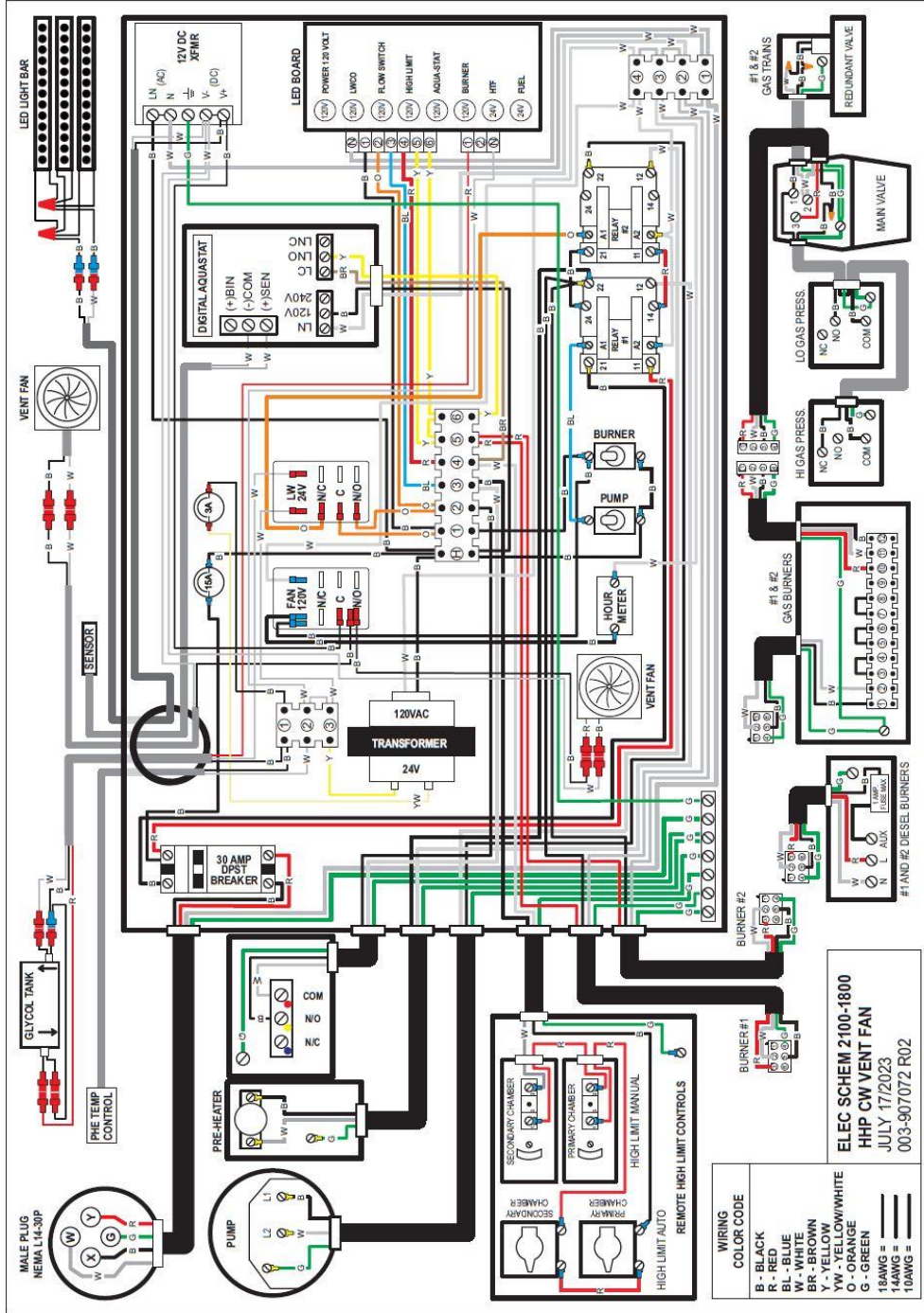

Figure 51 – 1800 Hydro Heat Pro Electrical Schematic

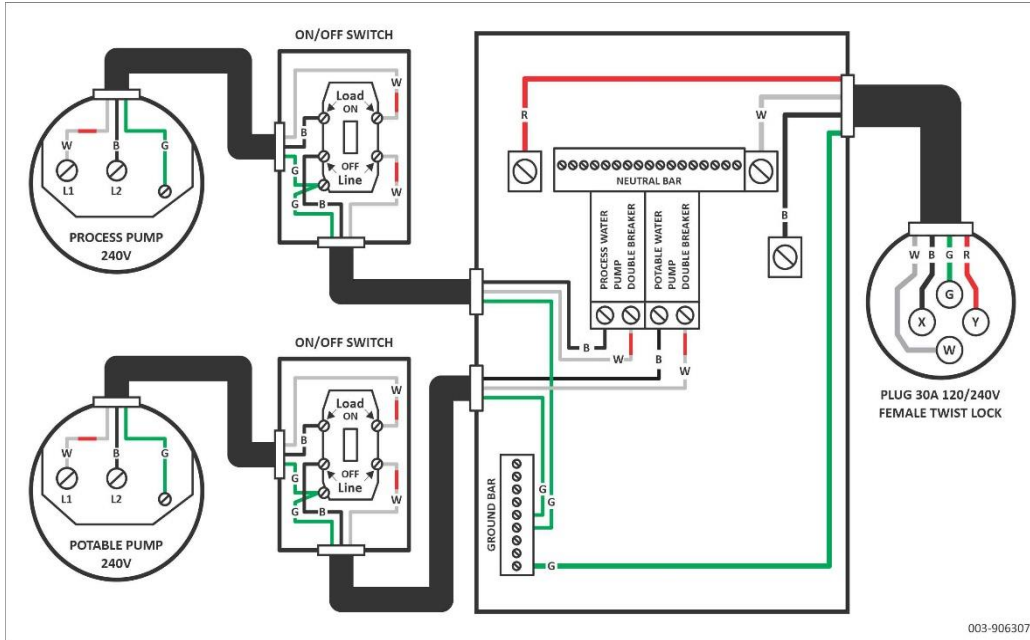

Figure 52 – 1800 Hydro Heat Pro heat pump module wiring

Trailer Electrical Schematics

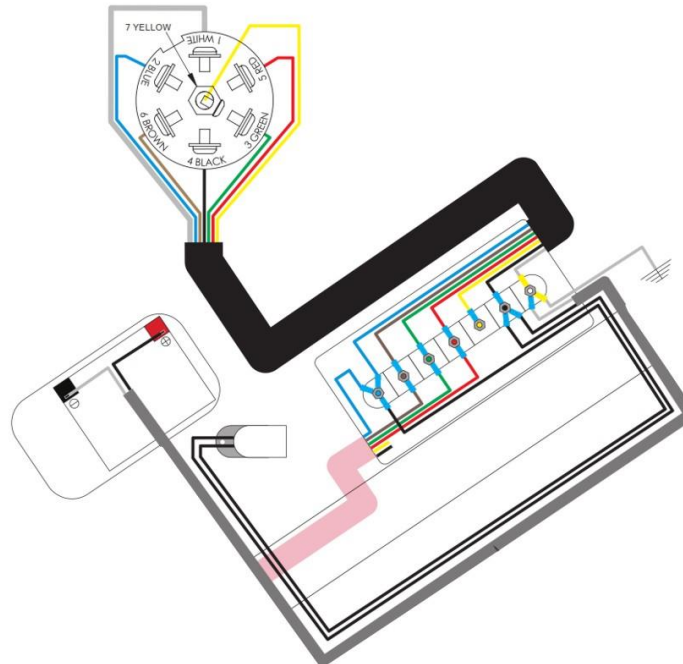

Figure 53 - Close-up View of Trailer Hook-up

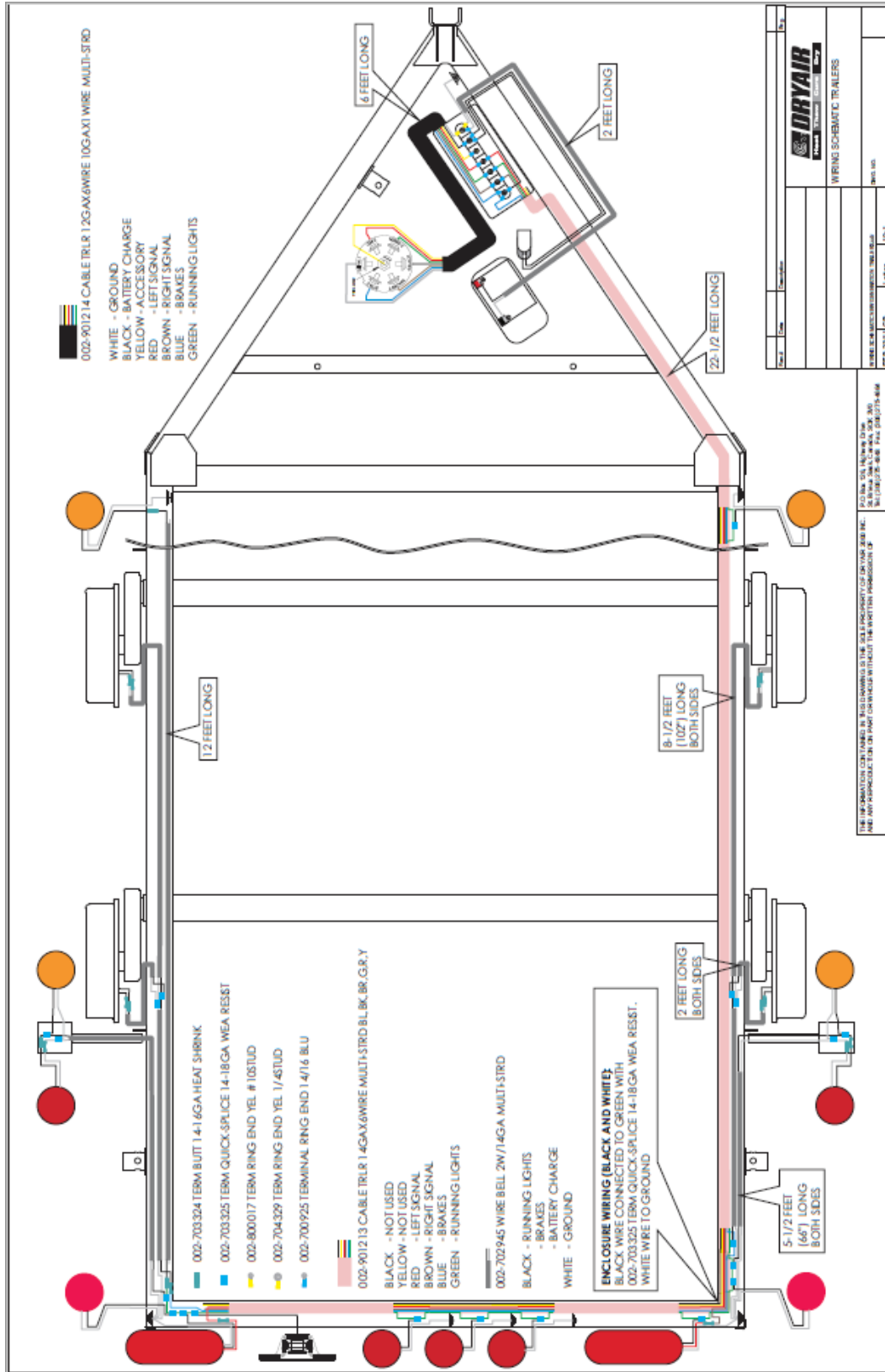

Figure 54 - Trailer Wiring Schematic

Heat Transfer Fluid Preheater Information

Function

- The design intention for the HTF preheater is to ensure a smooth start in cold environments. The preheater heats the glycol in the heat exchanger which in turn sends heated glycol to DryAir's patented air and fuel preheater to provide a controlled constant air and fuel temperature thus providing smooth start operations in cold weather.
- While using the HTF preheater it is recommended to have a supply temperature above 40°F (4°C) before turning on the pump and burner switch. The estimated time before these temperatures can be achieved will depend on the ambient temperature outside. Basically, the colder environment outside the longer it will take to achieve the recommended supply temperature.

DRYAIR's Patented HTF Preheater

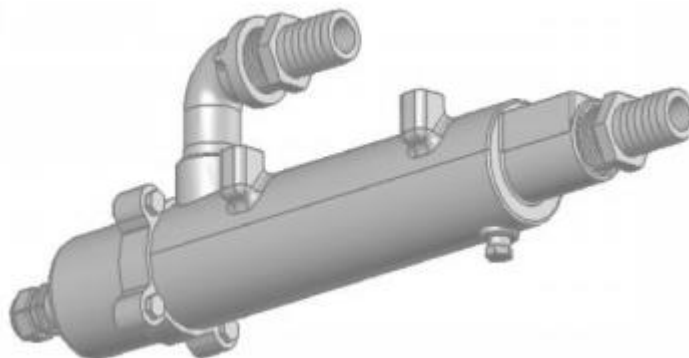

Figure 55 - HTF Preheater

Pros of Using HTF Preheater:

- Using the HTF preheater according to recommendations will ensure a smooth start in all weather conditions, thus providing a superior product to all users.
- Allows the machine to operate in even the coldest environments with fewer combustion issues.
- Less down time and reduced fuel costs as units will start and run at maximum efficiency.
- Having warm glycol reduces initial load to the glycol circulating pump at start up.
- Increase heat exchanger longevity and efficiency.
- Decreases maintenance costs due to the reduced stress on all components during cold startups.

Cons of Not Using HTF Preheater:

- Burner may not fire, which in turn will create down time on job locations. For competitor's units that do not have a preheater option, this typically means bringing the unit off site to a heated shop to allow the unit to thaw out before it will fire. Again, it will depend on the ambient temperature inside the shop as to how long this will take but in any event, it will take much longer compared to using the preheater on the DryAir unit.
- If the unit does start in cold temperatures, there is potential for the heat exchanger to accumulate soot due to not having a controlled environment of air and fuel going into the burner. Sooting will stop after the unit warms up if the settings on the burner are correct. Every 1 mm of soot accumulated on the heat exchanger results in a 5% loss of efficiency compared to a clean exchanger. Running the preheater on the DryAir unit eliminates the need to adjust burner settings in reaction to changing weather conditions.
- Decreases heat exchanger service life.
- Increases maintenance costs due to added stress on all components during cold startups.

In Conclusion

Using the preheater as instructed in the manual will allow you to operate DryAir units in colder climates without sacrificing efficiency or long-term reliability of the unit.

DryAir recommends planning ahead and starting the preheater to allow it to run while the unit is in transit to the jobsite (running on generator power) and while operators are reeling out and placing hose on the site. This will still make for productive use of the time while allowing the unit to benefit from the patented preheater feature.



If the operator decides they do not want to wait for the preheater to work, the DryAir unit will perform just like any of our competitor's units that do not have a preheater option.



Material Safety Data Sheets

The Material Safety Data Sheets (MSDS) included with this manual have been provided by DryAir's suppliers.



Certificate – Opinion of Compliance

Bolt-on Lifting Frame Assembly for DryAir 1.8 HHP System

Certificate No.: 670 **Project No.:** T21073P

Applies To: Lifting Frame Assembly (DRYAIR Dwg no. 018-906197) for DRYAIR 1.8 HHP

Manufacturer: DRYAIR Mfg. Corp. **Test Location:** PAMI, Humboldt, SK
St. Brieux, SK **Test Date:** May 21, 2020

Basis of Opinion: The Client previously tested the frame noted in PAMI Certificate No. 625. The Client now has an additional model 1.8 HYDRO-HEAT PRO that utilizes the same lifting lugs attached to a frame of the same dimensions, materials, and assembly methods as that which was previously tested. PAMI reviewed drawings 018-906197, 018-905033, 004-906198, 004-905039, 004-906200 and 004-905040 and confirmed the only differences between the frame tested and the new frame is the location of the lifting point on the trailer frame and the length of the vertical corner posts connecting the lifting frame to the trailer. PAMI's opinion is that these variations in the frame would not affect the ability of the lifting frame to meet the same performance as previously tested provided that the frame is connected in such a way to the trailer that the trailer center of gravity is centered in the frame, evenly loading the corner posts of the frame. Therefore, providing the new frame, lifting lugs, and materials are of the same dimensions, construction, and configuration as that previously tested, PAMI Certificate No. 625 would be applicable, and the design would be capable of lifting a maximum load of 11,533. In the case of the 1.8 HYDRO-HEAT PRO product depicted in drawing 004-906129, with a gross weight of 9,500, Certificate No. 625 would be applicable to this model and does not require retesting. The Client is responsible to ensure the lifting frame is located on the trailer such that the lift point passes through the centre of gravity of the complete assembly or is located such that the loading points are as close as possible to that which was originally tested in Certificate No. 625.

Original Test Reference: Lifting Frame Assembly (DRYAIR Dwg no. 018-905033) for DRYAIR 650GTS

- Corner posts (qty 4) consisting of:
 - HSS steel tube, 2 in. x 2 in. x 0.250 in. wall thickness
 - lifting bracket, 3/8 in. steel plate formed and with 1-3/4 in. hole for clevis pin or hook; welded to end of HSS steel tube
- End upper rails (qty 2) constructed from structural steel channel, 4 in. x 1.58 in. x 0.180 in. web thickness (C4 x 5.4)
- Side upper rails (qty 2) consisting of:
 - HSS steel tube, 3 in. x 2 in. x 0.188 in. wall thickness
 - mount bracket, 1/4 in. steel plate; welded to end of HSS steel tube
- End and side upper rails bolted to corner post lifting bracket with 1/2 in. fasteners (qty 2 at each end of rail)

Corner posts bolted to trailer mount bracket with 5/8 in. fasteners (qty 2 for each corner post)

Complied To: Current Province of Saskatchewan “The Occupational Health and Safety Regulations, 1996” Chapter O-1.1 Reg 1 – Part XIII, sections 203 and 206; Part XIV, sections 230 and 231.

Requirements of Standard: The lifting frame assembly must withstand a total applied load of at least five times the maximum weight of the 1.8 HYDRO-HEAT PRO system without failing. The maximum load applied divided by five will define the load rating of the lifting frame assembly.

Analysis: An engineering analysis utilizing a maximum force of 57,765 lbf applied to the lifting frame (5 x rated load of 11,553 lbf) was completed. Analysis was completed to validate that the corner posts did not supply any significant amount of rigidity to the frame at the max load. Results of the analysis showed no significant affect on the ability of the frame to carry the max load due to extending the corner posts from a length of 73 1/8 in. to 88 3/4 in.



***I hereby certify these results meet or exceed the requirements of the performance standards.
 This certificate is issued based upon test results, that subject to the conditions stated herein, would
 represent a sample suitable to demonstrate the range of compliance as stated.
 This Test Certificate shall not be reproduced except in full, without written approval of PAMI.***



Association of Professional Engineers & Geoscientists of Saskatchewan		
CERTIFICATE OF AUTHORIZATION		
PRAIRIE AGRICULTURE MACHINERY INSTITUTE		
Number C993		
Permission to Consult held by:		
Discipline	Sk. Reg. No.	Signature
Mechanical	09269	<i>Larry Johnson</i>
_____	_____	_____
_____	_____	_____

Certified by: Bryan Lung, P.Eng., M.Sc.
 Director, Project Management

Date: November 3, 2021



SAFETY DATA SHEET

Issuing Date 03-Jun-2019

Revision date 03-Jun-2019

Revision Number 1

1. Identification

Product identifier

Product Name BOSS Chill Propylene Glycol

Other means of identification

Product Code(s) GHSRBS-041

UN/ID no. UN 3082

Synonyms None

Recommended use of the chemical and restrictions on use

Recommended use Heat transfer medium

Restrictions on use No information available

Details of the supplier of the safety data sheet

Initial supplier identifier

BOSS Lubricants

Manufacturer Address

6303 30 ST SE Calgary, AB T2C 1R4

Emergency telephone number

Initial supplier phone number (800) 844-9457
Emergency Telephone Chemtrec 1-800-424-9300

2. Hazard(s) identification

Classification

Not a hazardous substance or mixture according to the Globally Harmonized System (GHS) and Canada's Hazardous Products Regulations

Label elements

Hazard statements

Not a hazardous substance or mixture according to the Globally Harmonized System (GHS) and Canada's Hazardous Products Regulations.



Precautionary Statements - Disposal

Dispose of contents/container in accordance with local, regional, national, and international regulations as applicable

Other information**3. Composition/information on ingredients****Substance**

Chemical name	CAS No.	Weight-%	Hazardous Material Information Review Act registry number (HMIRA registry #)	Date HMIRA filed and date exemption granted (if applicable)
Water	7732-18-5	0.1 - 1	-	
Propylene glycol	57-55-6	80 - 100	-	
PROPRIETARY ADDITIVES	PROPRIETARY	1 - 5	-	

If CAS number is "proprietary", the specific chemical identity and percentage of composition has been withheld as a trade secret.

4. First-aid measures**Description of first aid measures**

Inhalation	Remove to fresh air. If not breathing, give artificial respiration. IF exposed or concerned: Get medical advice/attention.
Eye contact	IF IN EYES: Rinse cautiously with water for several minutes. Remove contact lenses, if present and easy to do. Continue rinsing. Get medical attention if irritation develops and persists.
Skin contact	Wash off immediately with soap and plenty of water while removing all contaminated clothes and shoes. Get medical attention if symptoms occur.
Ingestion	Do NOT induce vomiting. Call a physician or poison control center immediately. If vomiting occurs spontaneously, keep head below hips to prevent aspiration. Never give anything by mouth to an unconscious person.

Most important symptoms and effects, both acute and delayed

Symptoms Prolonged contact may cause redness and irritation.

Indication of any immediate medical attention and special treatment needed

Note to physicians Treat symptomatically.

5. Fire-fighting measures

Suitable Extinguishing Media	Carbon dioxide (CO ₂). Foam. Dry chemical. Water spray or fog. Alcohol resistant foam.
Unsuitable extinguishing media	Do not scatter spilled material with high pressure water streams.
Specific hazards arising from the chemical	Use water spray to cool fire-exposed containers and structures. Isolate and restrict area access. Violent steam generation or eruption may occur upon application of direct water stream to hot liquids. Container may rupture from gas generation in a fire situation. Fight fire from a safe distance and from a protected location. Do not direct a solid stream of water or foam into hot, burning pools; this may cause frothing and increase fire intensity. Consider use of unmanned hose holder or monitor nozzles.
Explosion data	
Sensitivity to mechanical impact	None.
Sensitivity to static discharge	None.
Special protective equipment for fire-fighters	Firefighters should wear self-contained breathing apparatus and full firefighting turnout gear. Use personal protection equipment.

6. Accidental release measures

Personal precautions, protective equipment and emergency procedures

Personal precautions Use personal protective equipment as required. See section 8 for more information. Ensure adequate ventilation.

Methods and material for containment and cleaning up

Methods for containment Stop leak if you can do it without risk. Keep out of drains, sewers, ditches and waterways. Ventilate the area. Avoid breathing vapors or mists.

Methods for cleaning up Cover liquid spill with sand, earth or other noncombustible absorbent material. Prevent product from entering drains.

7. Handling and storage

Precautions for safe handling

Advice on safe handling Avoid breathing dust/fume/gas/mist/vapors/spray. Avoid contact with skin, eyes or clothing. Use only with adequate ventilation. Handle in accordance with good industrial hygiene and safety practice. Do not eat, drink or smoke when using this product. Do not ingest. If swallowed then seek immediate medical assistance. For industrial use only.

Conditions for safe storage, including any incompatibilities

Storage Conditions Keep container tightly closed in a dry and well-ventilated place. Keep away from heat, sparks, flame and other sources of ignition (i.e., pilot lights, electric motors and static electricity). Do not contaminate food or feed stuffs. Store only in containers resistant to alkaline solutions with a pH of 9.0 to 12.0.

8. Exposure controls/personal protection

Control parameters

Exposure Limits This product, as supplied, does not contain any hazardous materials with occupational exposure limits established by the region specific regulatory bodies.

Appropriate engineering controls

Engineering controls Ensure adequate ventilation, especially in confined areas.

Individual protection measures, such as personal protective equipment

Eye/face protection Wear safety glasses with side shields (or goggles). If splashes are likely to occur, wear safety glasses with side-shields. Avoid contact with eyes.

Hand protection Wear suitable gloves.

Skin and body protection Wear suitable protective clothing.

Respiratory protection No protective equipment is needed under normal use conditions. If exposure limits are exceeded or irritation is experienced, ventilation and evacuation may be required.

General hygiene considerations Handle in accordance with good industrial hygiene and safety practice.

9. Physical and chemical properties

Information on basic physical and chemical properties

Physical state Liquid
Appearance No information available
Color purple
Odor Odorless
Odor threshold No information available

<u>Property</u>	<u>Values</u>	<u>Remarks • Method</u>
pH	9.0– 10.5	
Melting point / freezing point	No data available	None known
Boiling point / boiling range	188 °C / 317 °F	ASTM D7213
Flash point	116 °C / 240 °F	ASTM D93
Evaporation rate	No data available	None known
Flammability (solid, gas)	No data available	None known
Flammability Limit in Air		None known
Upper flammability or explosive limits	No data available	
Lower flammability or explosive limits	No data available	
Vapor pressure	No data available	None known
Vapor density	No data available	None known
Relative density	No data available	None known
Water solubility	completely soluble	
Solubility in other solvents	No data available	None known

Partition coefficient	No data available	None known
Autoignition temperature	No data available	None known
Decomposition temperature	No data available	None known
Kinematic viscosity	No data available	None known
Dynamic viscosity	No data available	None known

Other information

Explosive properties	No information available.
Oxidizing properties	No information available.
Softening point	No information available
Molecular weight	No information available
VOC Content (%)	No information available
Liquid Density	No information available
Bulk density	No information available

10. Stability and reactivity

Reactivity	No information available.
Chemical stability	Stable under normal conditions.
Possibility of hazardous reactions	None under normal processing.
Conditions to avoid	Heat, flames and sparks.
Incompatible materials	Strong oxidizing agents. Strong acids.
Hazardous decomposition products	Thermal decomposition can lead to release of irritating and toxic gases and vapors.

11. Toxicological information**Information on likely routes of exposure****Product Information**

Inhalation	No known effects under normal use conditions.
Eye contact	Irritating to eyes.
Skin contact	Avoid contact with skin and clothing.
Ingestion	Harmful if swallowed. Ingestion of larger amounts may cause defects to the central nervous system (e.g. dizziness, headache). Ingestion may cause gastrointestinal irritation, nausea, vomiting and diarrhea. May cause adverse kidney effects.

Symptoms related to the physical, chemical and toxicological characteristics

Symptoms	No information available.
----------	---------------------------

Acute toxicity

Numerical measures of toxicity
No information available

Unknown acute toxicity No information available
Product Information

Chemical name	Oral LD50	Dermal LD50	Inhalation LC50
Propylene glycol 57-55-6	= 20 g/kg (Rat)	= 20800 mg/kg (Rabbit)	Not available

Delayed and immediate effects as well as chronic effects from short and long-term exposure

Skin corrosion/irritation Based on available data, the classification criteria are not met.

Serious eye damage/eye irritation Based on available data, the classification criteria are not met.

Respiratory or skin sensitization Based on available data, the classification criteria are not met.

Germ cell mutagenicity Based on available data, the classification criteria are not met.

Carcinogenicity Based on available data, the classification criteria are not met.

Reproductive toxicity Based on available data, the classification criteria are not met.

STOT - single exposure Based on available data, the classification criteria are not met.

STOT - repeated exposure Based on available data, the classification criteria are not met.

Aspiration hazard No information available.

12. Ecological information

Ecotoxicity Harmful to aquatic life.

Persistence and degradability No information available.

Bioaccumulation No information available.

Other adverse effects No information available.

13. Disposal considerations

Waste treatment methods

Waste from residues/unused products Dispose of waste in accordance with environmental legislation.

Contaminated packaging Do not reuse empty containers.

14. Transport information

<u>Transport Canada</u>	Not regulated
<u>TDG</u>	Not regulated
<u>DOT</u>	Not regulated unless shipping container holds at least 5,000 pounds.
UN/ID no.	UN 3082
Hazard class	9
Packing group	III
<u>MEX</u>	Not regulated
<u>ICAO (air)</u>	no data available
<u>IATA</u>	no data available
<u>IMDG</u>	no data available
<u>RID</u>	no data available
<u>ADR</u>	no data available
<u>ADN</u>	no data available

15. Regulatory information

Safety, health and environmental regulations/legislation specific for the substance or mixture

International Regulations

The Montreal Protocol on Substances that Deplete the Ozone Layer Not applicable

The Stockholm Convention on Persistent Organic Pollutants Not applicable

The Rotterdam Convention Not applicable

International Inventories

TSCA	Complies.
DSL/NDSL	Complies.
EINECS/ELINCS	Contact supplier for inventory compliance status.
ENCS	Contact supplier for inventory compliance status.
IECSC	Contact supplier for inventory compliance status.
KECL	Contact supplier for inventory compliance status.
PICCS	Contact supplier for inventory compliance status.
AICS	Contact supplier for inventory compliance status.

Legend:

TSCA - United States Toxic Substances Control Act Section 8(b) Inventory

DSL/NDSL - Canadian Domestic Substances List/Non-Domestic Substances List

EINECS/ELINCS - European Inventory of Existing Chemical Substances/European List of Notified Chemical Substances

ENCS - Japan Existing and New Chemical Substances

IECSC - China Inventory of Existing Chemical Substances

KECL - Korean Existing and Evaluated Chemical Substances

PICCS - Philippines Inventory of Chemicals and Chemical Substances

AICS - Australian Inventory of Chemical Substances

16. Other information

NFPA	Health hazards 2	Flammability 1	Instability 0	Physical and chemical properties -
HMIS	Health hazards 2	Flammability 1	Physical hazards 0	Personal protection X

Key or legend to abbreviations and acronyms used in the safety data sheet**Legend Section 8: EXPOSURE CONTROLS/PERSONAL PROTECTION**

TWA	TWA (time-weighted average)	STEL	STEL (Short Term Exposure Limit)
Ceiling	Maximum limit value	*	Skin designation

Key literature references and sources for data used to compile the SDS

Agency for Toxic Substances and Disease Registry (ATSDR)
 U.S. Environmental Protection Agency ChemView Database
 European Food Safety Authority (EFSA)
 EPA (Environmental Protection Agency)
 Acute Exposure Guideline Level(s) (AEGl(s))
 U.S. Environmental Protection Agency Federal Insecticide, Fungicide, and Rodenticide Act
 U.S. Environmental Protection Agency High Production Volume Chemicals
 Food Research Journal
 Hazardous Substance Database
 International Uniform Chemical Information Database (IUCLID)
 Japan GHS Classification
 Australia National Industrial Chemicals Notification and Assessment Scheme (NICNAS)
 NIOSH (National Institute for Occupational Safety and Health)
 National Library of Medicine's ChemID Plus (NLM CIP)
 National Library of Medicine's PubMed database (NLM PUBMED)
 National Toxicology Program (NTP)
 New Zealand's Chemical Classification and Information Database (CCID)
 Organization for Economic Co-operation and Development Environment, Health, and Safety Publications
 Organization for Economic Co-operation and Development High Production Volume Chemicals Program
 Organization for Economic Co-operation and Development Screening Information Data Set
 RTECS (Registry of Toxic Effects of Chemical Substances)
 World Health Organization

Issuing Date 03-Jun-2019

Revision date 04-Jun-2019

Revision Note No information available.

Disclaimer

The information provided in this Safety Data Sheet is correct to the best of our knowledge, information and belief at the date of its publication. The information given is designed only as a guidance for safe handling, use, processing, storage, transportation, disposal and release and is not to be considered a warranty or quality specification. The information relates only to the specific material designated and may not be valid for such material used in combination with any other materials or in any process, unless specified in the text.

End of Safety Data Sheet

Data for Regulatory Rules

Region	Template name	Revision Note
Canada	HGHS	2.0

GHS Product Information

pH	9.0– 10.5
Physical state	Liquid
Flash point °C	116
Boiling point / boiling range °C	188

Component Information

Canada

GHS Classification

Not Hazardous

Not a hazardous substance or mixture according to the Globally Harmonized System (GHS) and Canada's Hazardous Products Regulations

Precautionary Statements - Disposal

Dispose of contents/container in accordance with local, regional, national, and international regulations as applicable



SAFETY DATA SHEET

DOW CHEMICAL CANADA ULC

Product name: DOWFROST™ Heat Transfer Fluid

Issue Date: 12/16/2019

Print Date: 12/17/2019

DOW CHEMICAL CANADA ULC encourages and expects you to read and understand the entire (M)SDS, as there is important information throughout the document. We expect you to follow the precautions identified in this document unless your use conditions would necessitate other appropriate methods or actions.

1. IDENTIFICATION

Product name: DOWFROST™ Heat Transfer Fluid

Recommended use of the chemical and restrictions on use

Identified uses: Intended as a heat transfer fluid for closed-loop systems. This product is acceptable for use where there is possibility of incidental food contact and as a product for use in the immersion or spray freezing of wrapped meat and packaged poultry products. We recommend that you use this product in a manner consistent with the listed use. If your intended use is not consistent with the stated use, please contact your sales or technical service representative.

COMPANY IDENTIFICATION

DOW CHEMICAL CANADA ULC
#2400, 215 - 2ND STREET S.W.
CALGARY AB T2P 1M4
CANADA

Customer Information Number:

800-258-2436
SDSQuestion@dow.com

EMERGENCY TELEPHONE NUMBER

24-Hour Emergency Contact (transportation emergencies only): 1-800-424-9300

Local Emergency Contact (transportation emergencies only): 1-800-424-9300

24-Hour Emergency Contact: 1-989-636-4400

2. HAZARDS IDENTIFICATION

Hazard classification

This product is not hazardous under the criteria of the Hazardous Products Regulation (HPR) as implemented under the Workplace Hazardous Materials Information System (WHMIS 2015).

Other hazards

No data available

3. COMPOSITION/INFORMATION ON INGREDIENTS

This product is a mixture.

Component	CASRN	Concentration (w/w)
Propylene glycol	57-55-6	> 95.0 %
Inorganic corrosion inhibitor	not hazardous	< 3.0 %
Water	7732-18-5	< 3.0 %

4. FIRST AID MEASURES

Description of first aid measures

General advice:

If potential for exposure exists refer to Section 8 for specific personal protective equipment.

Inhalation: Move person to fresh air; if effects occur, consult a physician.

Skin contact: Wash off with plenty of water.

Eye contact: Flush eyes thoroughly with water for several minutes. Remove contact lenses after the initial 1-2 minutes and continue flushing for several additional minutes. If effects occur, consult a physician, preferably an ophthalmologist.

Ingestion: Rinse mouth with water. No emergency medical treatment necessary.

Most important symptoms and effects, both acute and delayed:

Aside from the information found under Description of first aid measures (above) and Indication of immediate medical attention and special treatment needed (below), any additional important symptoms and effects are described in Section 11: Toxicology Information.

Indication of any immediate medical attention and special treatment needed

Notes to physician: No specific antidote. Treatment of exposure should be directed at the control of symptoms and the clinical condition of the patient.

5. FIREFIGHTING MEASURES

Extinguishing media

Suitable extinguishing media: Water fog or fine spray.. Dry chemical fire extinguishers.. Carbon dioxide fire extinguishers.. Foam.. Alcohol resistant foams (ATC type) are preferred. General purpose synthetic foams (including AFFF) or protein foams may function, but will be less effective..

Unsuitable extinguishing media: Do not use direct water stream.. May spread fire..

Special hazards arising from the substance or mixture

Hazardous combustion products: During a fire, smoke may contain the original material in addition to combustion products of varying composition which may be toxic and/or irritating.. Combustion products may include and are not limited to:.. Carbon monoxide.. Carbon dioxide..

Unusual Fire and Explosion Hazards: Container may rupture from gas generation in a fire situation.. Violent steam generation or eruption may occur upon application of direct water stream to hot liquids..

Advice for firefighters

Fire Fighting Procedures: Keep people away. Isolate fire and deny unnecessary entry.. Use water spray to cool fire exposed containers and fire affected zone until fire is out and danger of reignition has passed.. Fight fire from protected location or safe distance. Consider the use of unmanned hose holders or monitor nozzles.. Immediately withdraw all personnel from the area in case of rising sound from venting safety device or discoloration of the container.. Burning liquids may be extinguished by dilution with water.. Do not use direct water stream. May spread fire.. Move container from fire area if this is possible without hazard.. Burning liquids may be moved by flushing with water to protect personnel and minimize property damage..

Special protective equipment for firefighters: Wear positive-pressure self-contained breathing apparatus (SCBA) and protective fire fighting clothing (includes fire fighting helmet, coat, trousers, boots, and gloves).. If protective equipment is not available or not used, fight fire from a protected location or safe distance..

6. ACCIDENTAL RELEASE MEASURES

Personal precautions, protective equipment and emergency procedures: Use appropriate safety equipment. For additional information, refer to Section 8, Exposure Controls and Personal Protection.

Environmental precautions: Prevent from entering into soil, ditches, sewers, waterways and/or groundwater. See Section 12, Ecological Information.

Methods and materials for containment and cleaning up: Small spills: Absorb with materials such as: Cat litter. Sawdust. Vermiculite. Zorb-all®. Collect in suitable and properly labeled containers. Large spills: Dike area to contain spill. Recover spilled material if possible. See Section 13, Disposal Considerations, for additional information.

7. HANDLING AND STORAGE

Precautions for safe handling: No special precautions required. Keep container closed. See Section 8, EXPOSURE CONTROLS AND PERSONAL PROTECTION. Spills of these organic materials on hot fibrous insulations may lead to lowering of the autoignition temperatures possibly resulting in spontaneous combustion.

Conditions for safe storage: Do not store in: Galvanized steel. Opened or unlabeled containers. Store in original unopened container. See Section 10 for more specific information. Additional storage

and handling information on this product may be obtained by calling your sales or customer service contact.

Storage stability

Shelf life: Use within 60 Month

8. EXPOSURE CONTROLS/PERSONAL PROTECTION

Control parameters

If exposure limits exist, they are listed below. If no exposure limits are displayed, then no values are applicable.

Consult local authorities for recommended exposure limits.

Component	Regulation	Type of listing	Value
Propylene glycol	US WEEL	TWA	10 mg/m3
	CA ON OEL	TWAEV Total	155 mg/m3 50 ppm
	CA ON OEL	TWAEV	10 mg/m3
	Further information: C: For assessing the visibility in a work environment where 1,2-propylene glycol aerosol is present.		
	CA ON OEL	TWA	155 mg/m3 50 ppm
	CA ON OEL	TWA	10 mg/m3
	Further information: (c): For assessing the visibility in a work environment where 1,2-propylene glycol aerosol is present		
	CA ON OEL	TWA Vapour and aerosols	155 mg/m3 50 ppm
	CA ON OEL	TWA aerosol	10 mg/m3
	Further information: (c): For assessing the visibility in a work environment where 1,2-propylene glycol aerosol is present		

Exposure controls

Engineering controls: Use local exhaust ventilation, or other engineering controls to maintain airborne levels below exposure limit requirements or guidelines. If there are no applicable exposure limit requirements or guidelines, general ventilation should be sufficient for most operations. Local exhaust ventilation may be necessary for some operations.

Individual protection measures

Eye/face protection: Use safety glasses (with side shields).

Skin protection

Hand protection: Use gloves chemically resistant to this material when prolonged or frequently repeated contact could occur. Examples of preferred glove barrier materials include: Butyl rubber. Natural rubber ("latex"). Neoprene. Nitrile/butadiene rubber ("nitrile" or "NBR"). Polyethylene. Ethyl vinyl alcohol laminate ("EVAL"). Polyvinyl chloride ("PVC" or "vinyl"). Avoid gloves made of: Polyvinyl alcohol ("PVA"). NOTICE: The selection of a specific glove for a particular application and duration of use in a workplace should also take into account all relevant workplace factors such as, but not limited to: Other chemicals which may be handled, physical requirements (cut/puncture protection, dexterity, thermal protection), potential body reactions to glove materials, as well as the instructions/specifications provided by the glove supplier.

Other protection: Wear clean, body-covering clothing.

Respiratory protection: Respiratory protection should be worn when there is a potential to exceed the exposure limit requirements or guidelines. If there are no applicable exposure limit

requirements or guidelines, wear respiratory protection when adverse effects, such as respiratory irritation or discomfort have been experienced, or where indicated by your risk assessment process. In misty atmospheres, use an approved particulate respirator. The following should be effective types of air-purifying respirators: Organic vapor cartridge with a particulate pre-filter.

9. PHYSICAL AND CHEMICAL PROPERTIES

Appearance

Physical state	Liquid.
Color	Colorless
Odor	Characteristic
Odor Threshold	No test data available
pH	10.0 50% <i>Literature</i>
Melting point/range	Not applicable to liquids
Freezing point	supercools
Boiling point (760 mmHg)	152 °C <i>Literature</i>
Flash point	closed cup 104 °C <i>Pensky-Martens Closed Cup ASTM D 93</i> (based on major component), Propylene glycol. open cup <i>Cleveland Open Cup ASTM D92</i> None
Evaporation Rate (Butyl Acetate = 1)	<0.5 <i>Estimated.</i>
Flammability (solid, gas)	Not applicable to liquids
Flammability (liquids)	Not expected to be a static-accumulating flammable liquid.
Lower explosion limit	2.6 % vol <i>Literature</i> Propylene glycol.
Upper explosion limit	12.5 % vol <i>Literature</i> Propylene glycol.
Vapor Pressure	2.2 mmHg <i>Literature</i>
Relative Vapor Density (air = 1)	>1.0 <i>Literature</i>
Relative Density (water = 1)	1.05 at 20 °C / 20 °C <i>Literature</i>
Water solubility	<i>Literature</i> completely soluble
Partition coefficient: n-octanol/water	No data available
Auto-ignition temperature	371 °C <i>Literature</i> Propylene glycol.
Decomposition temperature	No test data available
Kinematic Viscosity	43.4 cSt at 20 °C <i>Literature</i>
Explosive properties	No data available
Oxidizing properties	No data available
Molecular weight	76.9 g/mol <i>Literature</i>

NOTE: The physical data presented above are typical values and should not be construed as a specification.

10. STABILITY AND REACTIVITY

Reactivity: No data available

Chemical stability: Stable under recommended storage conditions. See Storage, Section 7.
Hygroscopic

Possibility of hazardous reactions: Polymerization will not occur.

Conditions to avoid: Exposure to elevated temperatures can cause product to decompose. Generation of gas during decomposition can cause pressure in closed systems. Avoid direct sunlight or ultraviolet sources.

Incompatible materials: Avoid contact with: Strong acids. Strong bases. Strong oxidizers.

Hazardous decomposition products: Decomposition products depend upon temperature, air supply and the presence of other materials.. Decomposition products can include and are not limited to: Aldehydes.. Alcohols.. Ethers.. Organic acids..

11. TOXICOLOGICAL INFORMATION

Toxicological information appears in this section when such data is available.

Information on likely routes of exposure

Ingestion, Inhalation, Skin contact, Eye contact.

Acute toxicity (represents short term exposures with immediate effects - no chronic/delayed effects known unless otherwise noted)

Acute oral toxicity

Very low toxicity if swallowed. Harmful effects not anticipated from swallowing small amounts.

For the major component(s): Propylene glycol.
LD50, Rat, > 20,000 mg/kg

Information for components:

Propylene glycol

LD50, Rat, > 20,000 mg/kg

Inorganic corrosion inhibitor

LD50, Rat, female, > 2,000 mg/kg No deaths occurred at this concentration.

Acute dermal toxicity

Prolonged skin contact is unlikely to result in absorption of harmful amounts.

For the major component(s): Propylene glycol.
LD50, Rabbit, > 20,000 mg/kg

Information for components:

Propylene glycol

LD50, Rabbit, > 2,000 mg/kg No deaths occurred at this concentration.

Inorganic corrosion inhibitor

LD50, Rabbit, > 5,000 mg/kg

Acute inhalation toxicity

At room temperature, exposure to vapor is minimal due to low volatility. Mist may cause irritation of upper respiratory tract (nose and throat).

For the major component(s):

LC50, Rat, 4 Hour, vapour, 6.15 mg/l No deaths occurred following exposure to a saturated atmosphere.

Information for components:

Propylene glycol

LC50, Rabbit, 2 Hour, dust/mist, 317.042 mg/l No deaths occurred at this concentration.

Inorganic corrosion inhibitor

Based on information for a similar material: Maximum attainable concentration. LC50, Rat, male and female, 4 Hour, dust/mist, > 0.83 mg/l No deaths occurred at this concentration.

Skin corrosion/irritation

Based on information for component(s):

Prolonged contact is essentially nonirritating to skin.

Repeated contact may cause flaking and softening of skin.

Information for components:

Propylene glycol

Prolonged contact is essentially nonirritating to skin.

Repeated contact may cause flaking and softening of skin.

Inorganic corrosion inhibitor

Prolonged contact may cause slight skin irritation with local redness.

Serious eye damage/eye irritation

Based on information for component(s):

May cause slight temporary eye irritation.

Corneal injury is unlikely.

Information for components:

Propylene glycol

May cause slight temporary eye irritation.

Corneal injury is unlikely.

Mist may cause eye irritation.

Inorganic corrosion inhibitor

May cause slight eye irritation.

May cause slight temporary corneal injury.

Dust may irritate eyes.
Mist may cause eye irritation.

Sensitization

For the major component(s):
Did not cause allergic skin reactions when tested in humans.

For respiratory sensitization:
No relevant data found.

Information for components:

Propylene glycol

Did not cause allergic skin reactions when tested in humans.

For respiratory sensitization:
No relevant data found.

Inorganic corrosion inhibitor

For similar material(s):
Did not demonstrate the potential for contact allergy in mice.

For respiratory sensitization:
No relevant data found.

Specific Target Organ Systemic Toxicity (Single Exposure)

Evaluation of available data suggests that this material is not an STOT-SE toxicant.

Information for components:

Propylene glycol

Evaluation of available data suggests that this material is not an STOT-SE toxicant.

Aspiration Hazard

Based on physical properties, not likely to be an aspiration hazard.

Information for components:

Propylene glycol

Based on physical properties, not likely to be an aspiration hazard.

Chronic toxicity (represents longer term exposures with repeated dose resulting in chronic/delayed effects - no immediate effects known unless otherwise noted)

Specific Target Organ Systemic Toxicity (Repeated Exposure)

In rare cases, repeated excessive exposure to propylene glycol may cause central nervous system effects.

Information for components:

Propylene glycol

In rare cases, repeated excessive exposure to propylene glycol may cause central nervous system effects.

Inorganic corrosion inhibitor

Based on available data, repeated exposures are not anticipated to cause significant adverse effects.

Carcinogenicity

Similar formulations did not cause cancer in laboratory animals.

Information for components:

Propylene glycol

Did not cause cancer in laboratory animals.

Inorganic corrosion inhibitor

No relevant data found.

Teratogenicity

For the major component(s): Did not cause birth defects or any other fetal effects in laboratory animals.

Information for components:

Propylene glycol

Did not cause birth defects or any other fetal effects in laboratory animals.

Inorganic corrosion inhibitor

For similar material(s): Did not cause birth defects or any other fetal effects in laboratory animals.

Reproductive toxicity

For the major component(s): In animal studies, did not interfere with reproduction. In animal studies, did not interfere with fertility.

Information for components:

Propylene glycol

In animal studies, did not interfere with reproduction. In animal studies, did not interfere with fertility.

Inorganic corrosion inhibitor

For similar material(s): In animal studies, did not interfere with reproduction.

Mutagenicity

In vitro genetic toxicity studies were negative. For the major component(s): Animal genetic toxicity studies were negative.

Information for components:

Propylene glycol

In vitro genetic toxicity studies were negative. Animal genetic toxicity studies were negative.

Inorganic corrosion inhibitor

In vitro genetic toxicity studies were negative.

12. ECOLOGICAL INFORMATION

Ecotoxicological information appears in this section when such data is available.

Toxicity

Propylene glycol

Acute toxicity to fish

Material is practically non-toxic to aquatic organisms on an acute basis (LC50/EC50/EL50/LL50 >100 mg/L in the most sensitive species tested).
LC50, Oncorhynchus mykiss (rainbow trout), static test, 96 Hour, 40,613 mg/l, OECD Test Guideline 203

Acute toxicity to aquatic invertebrates

LC50, Ceriodaphnia dubia (water flea), static test, 48 Hour, 18,340 mg/l, OECD Test Guideline 202

Acute toxicity to algae/aquatic plants

ErC50, Pseudokirchneriella subcapitata (green algae), 96 Hour, Growth rate inhibition, 19,000 mg/l, OECD Test Guideline 201

Toxicity to bacteria

NOEC, Pseudomonas putida, 18 Hour, > 20,000 mg/l

Chronic toxicity to aquatic invertebrates

NOEC, Ceriodaphnia dubia (water flea), semi-static test, 7 d, number of offspring, 13,020 mg/l

Inorganic corrosion inhibitor

Acute toxicity to fish

Material is practically non-toxic to aquatic organisms on an acute basis (LC50/EC50/EL50/LL50 >100 mg/L in the most sensitive species tested).
LC50, Leuciscus idus (Golden orfe), static test, 48 Hour, > 900 mg/l, Method Not Specified.

Persistence and degradability

Propylene glycol

Biodegradability: Material is readily biodegradable. Passes OECD test(s) for ready biodegradability. Biodegradation may occur under anaerobic conditions (in the absence of oxygen).

10-day Window: Pass

Biodegradation: 81 %

Exposure time: 28 d

Method: OECD Test Guideline 301F or Equivalent

10-day Window: Not applicable

Biodegradation: 96 %

Exposure time: 64 d

Method: OECD Test Guideline 306 or Equivalent

Theoretical Oxygen Demand: 1.68 mg/mg

Chemical Oxygen Demand: 1.53 mg/mg

Biological oxygen demand (BOD)

Incubation Time	BOD
5 d	69.000 %
10 d	70.000 %
20 d	86.000 %

Photodegradation

Atmospheric half-life: 10 Hour

Method: Estimated.

Inorganic corrosion inhibitor

Biodegradability: Biodegradation is not applicable.

Bioaccumulative potential

Propylene glycol

Bioaccumulation: Bioconcentration potential is low (BCF < 100 or Log Pow < 3).

Partition coefficient: n-octanol/water(log Pow): -1.07 Measured

Bioconcentration factor (BCF): 0.09 Estimated.

Inorganic corrosion inhibitor

Bioaccumulation: No bioconcentration is expected because of the relatively high water solubility.

Mobility in soil

Propylene glycol

Given its very low Henry's constant, volatilization from natural bodies of water or moist soil is not expected to be an important fate process.

Potential for mobility in soil is very high (Koc between 0 and 50).

Partition coefficient (Koc): < 1 Estimated.

Inorganic corrosion inhibitor

No relevant data found.

13. DISPOSAL CONSIDERATIONS

Disposal methods: DO NOT DUMP INTO ANY SEWERS, ON THE GROUND, OR INTO ANY BODY OF WATER. All disposal practices must be in compliance with all Federal, State/Provincial and local laws and regulations. Regulations may vary in different locations. Waste characterizations and compliance with applicable laws are the responsibility solely of the waste generator. AS YOUR SUPPLIER, WE HAVE NO CONTROL OVER THE MANAGEMENT PRACTICES OR MANUFACTURING PROCESSES OF PARTIES HANDLING OR USING THIS MATERIAL. THE INFORMATION PRESENTED HERE PERTAINS ONLY TO THE PRODUCT AS SHIPPED IN ITS INTENDED CONDITION AS DESCRIBED IN MSDS SECTION: Composition Information. FOR

UNUSED & UNCONTAMINATED PRODUCT, the preferred options include sending to a licensed, permitted: Recycler. Reclaimer. Incinerator or other thermal destruction device.

14. TRANSPORT INFORMATION

TDG

Not regulated for transport

Classification for SEA transport (IMO-IMDG):

	Not regulated for transport
Transport in bulk according to Annex I or II of MARPOL 73/78 and the IBC or IGC Code	Consult IMO regulations before transporting ocean bulk

Classification for AIR transport (IATA/ICAO):

Not regulated for transport

This information is not intended to convey all specific regulatory or operational requirements/information relating to this product. Transportation classifications may vary by container volume and may be influenced by regional or country variations in regulations. Additional transportation system information can be obtained through an authorized sales or customer service representative. It is the responsibility of the transporting organization to follow all applicable laws, regulations and rules relating to the transportation of the material.

15. REGULATORY INFORMATION

Canadian Domestic Substances List (DSL)

All substances contained in this product are listed on the Canadian Domestic Substances List (DSL) or are not required to be listed.

16. OTHER INFORMATION

Hazard Rating System

NFPA

Health	Flammability	Instability
0	1	0

Revision

Identification Number: 11045208 / A208 / Issue Date: 12/16/2019 / Version: 8.0

Most recent revision(s) are noted by the bold, double bars in left-hand margin throughout this document.

Legend

CA ON OEL	Canada. Ontario OELs
TWA	8-hr TWA
TWAEV	time-weighted average exposure value
US WEEL	USA. Workplace Environmental Exposure Levels (WEEL)

Full text of other abbreviations

AICS - Australian Inventory of Chemical Substances; ASTM - American Society for the Testing of Materials; bw - Body weight; CERCLA - Comprehensive Environmental Response, Compensation, and Liability Act; CMR - Carcinogen, Mutagen or Reproductive Toxicant; DIN - Standard of the German Institute for Standardisation; DOT - Department of Transportation; DSL - Domestic Substances List (Canada); ECx - Concentration associated with x% response; EHS - Extremely Hazardous Substance; ELx - Loading rate associated with x% response; EmS - Emergency Schedule; ENCS - Existing and New Chemical Substances (Japan); ErCx - Concentration associated with x% growth rate response; ERG - Emergency Response Guide; GHS - Globally Harmonized System; GLP - Good Laboratory Practice; HMIS - Hazardous Materials Identification System; IARC - International Agency for Research on Cancer; IATA - International Air Transport Association; IBC - International Code for the Construction and Equipment of Ships carrying Dangerous Chemicals in Bulk; IC50 - Half maximal inhibitory concentration; ICAO - International Civil Aviation Organization; IECSC - Inventory of Existing Chemical Substances in China; IMDG - International Maritime Dangerous Goods; IMO - International Maritime Organization; ISHL - Industrial Safety and Health Law (Japan); ISO - International Organisation for Standardization; KECI - Korea Existing Chemicals Inventory; LC50 - Lethal Concentration to 50 % of a test population; LD50 - Lethal Dose to 50% of a test population (Median Lethal Dose); MARPOL - International Convention for the Prevention of Pollution from Ships; MSHA - Mine Safety and Health Administration; n.o.s. - Not Otherwise Specified; NFPA - National Fire Protection Association; NO(A)EC - No Observed (Adverse) Effect Concentration; NO(A)EL - No Observed (Adverse) Effect Level; NOELR - No Observable Effect Loading Rate; NTP - National Toxicology Program; NZIoC - New Zealand Inventory of Chemicals; OECD - Organization for Economic Co-operation and Development; OPPTS - Office of Chemical Safety and Pollution Prevention; PBT - Persistent, Bioaccumulative and Toxic substance; PICCS - Philippines Inventory of Chemicals and Chemical Substances; (Q)SAR - (Quantitative) Structure Activity Relationship; RCRA - Resource Conservation and Recovery Act; REACH - Regulation (EC) No 1907/2006 of the European Parliament and of the Council concerning the Registration, Evaluation, Authorisation and Restriction of Chemicals; RQ - Reportable Quantity; SADT - Self-Accelerating Decomposition Temperature; SARA - Superfund Amendments and Reauthorization Act; SDS - Safety Data Sheet; TCSI - Taiwan Chemical Substance Inventory; TSCA - Toxic Substances Control Act (United States); UN - United Nations; UNRTDG - United Nations Recommendations on the Transport of Dangerous Goods; vPvB - Very Persistent and Very Bioaccumulative

Information Source and References

This SDS is prepared by Product Regulatory Services and Hazard Communications Groups from information supplied by internal references within our company.

DOW CHEMICAL CANADA ULC urges each customer or recipient of this (M)SDS to study it carefully and consult appropriate expertise, as necessary or appropriate, to become aware of and understand the data contained in this (M)SDS and any hazards associated with the product. The information herein is provided in good faith and believed to be accurate as of the effective date shown above. However, no warranty, express or implied, is given. Regulatory requirements are subject to change and may differ between various locations. It is the buyer's/user's responsibility to ensure that his

activities comply with all federal, state, provincial or local laws. The information presented here pertains only to the product as shipped. Since conditions for use of the product are not under the control of the manufacturer, it is the buyer's/user's duty to determine the conditions necessary for the safe use of this product. Due to the proliferation of sources for information such as manufacturer-specific (M)SDSs, we are not and cannot be responsible for (M)SDSs obtained from any source other than ourselves. If you have obtained an (M)SDS from another source or if you are not sure that the (M)SDS you have is current, please contact us for the most current version.

CA