



## Operators Manual

**GREENTHAW SYSTEMS  
MODEL 300GTS**

S.N. 155301 -

DRYAIR Manufacturing Corp.  
Box 126, 400 Service Road  
St. Brieux, SK, Canada  
S0K 3V0  
Tel: (306) 275-4848 1-888-750-1700  
Fax: (306) 275-4664



# Table of Contents

<b>Warranty Policies &amp; Claim Procedures</b>	<b>1-1</b>
Warranty Policies.....	1-1
Warranty Claim Procedure.....	1-2
<b>Safety Concerns</b>	<b>2-1</b>
General Safety Guidelines.....	2-1
Water Heater Module.....	2-2
Heat Transfer Fluid.....	2-2
Material Safety Data Sheet – Boss Chill PG.....	2-3
Material Safety Data Sheet – Dowfrost*.....	2-11
<b>Introduction</b>	<b>3-1</b>
Components.....	3-1
Central mobile Enclosure.....	3-1
Passive heat transfer.....	3-2
Accessories.....	3-2
How the system works.....	3-3
<b>Setup (CME)</b>	<b>4-1</b>
Required safety clearances.....	4-1
Elevation concerns.....	4-1
Electrical requirements & connections.....	4-2
Heat transfer fluid “HTF”.....	4-2
Fuel.....	4-3
Primary “HTF” circulation lines.....	4-3
Burner Removal.....	4-3
Burner Installation.....	4-3
Initial Settings For The Actuator Motor on the Flow Reversers for the GTS300.....	4-4
<b>Operation (CME)</b>	<b>5-1</b>
Purging air from the “HTF” circulation system.....	5-1
Before firing the system.....	5-3
Cold start procedure.....	5-4
Temperate start procedure.....	5-5
Purging air from the fuel system.....	5-6
Adding “HTF” to system.....	5-7
<b>Setup/Operation/Maintenance (HR2250)</b>	<b>6-1</b>
Manual Controls.....	6-1
Mechanical Drive Components.....	6-2
<b>Troubleshooting (CME)</b>	<b>7-1</b>
<b>Maintenance</b>	<b>8-1</b>
Central Heating Module.....	8-1
<b>Addendum</b>	<b>9-1</b>
Important certification & Operational Information Decals.....	9-1
Non-pressure vessel decal.....	9-1
Certification & Heater Specifications.....	9-2
Electrical schematics.....	9-3

# Warranty Policies & Claim Procedures

**DRYAIR MANUFACTURING CORP.** (referred to within as DRYAIR) warrants its new, unused equipment to be free of defects in material and workmanship at the time of delivery to the original retail purchaser.

## Warranty Policies

### Basic warranty policy

- DRYAIR will repair or replace, at its option, without charge, any defective part of the equipment for a period of twelve (12) months from delivery to the first retail purchaser, F.O.B St. Brieux, SK., Canada.
- Mileage is not covered. Any parts that are covered by an extended warranty published by DRYAIR are an exception to the Basic Warranty policy and are to be warranted as per the details of the Extended Warranty Policy.
- Labor is covered as per DRYAIR flat labor rate.
- The Warranty Policy, terms and conditions, may change from time to time without prior notice.
- Warranty terms and conditions are transferable in the event of the sale to a second owner.
- Replacement parts will be warranted for 90 days from the repair date. Bill of sale must accompany the warranty claim.
- The terms of this Warranty Policy are subject to provincial and state legislation. DRYAIR reserves the right to make modifications in accordance with provincial and state legislation without prior notice or obligation.

### Extended warranty policy

#### Heat exchanger

- An extended warranty is available on the heat exchanger unit of the water heater assembly. The available warranty for a part, under the extended warranty policy, is prorated by 20% per year.
- (Shipment date is the date to be used for the commencement of the warranty period).
- Coverage schedule
  - Year 1 - 100%
  - Year 2 - 80%
  - Year 3 - 60%
  - Year 4 - 40%
  - Year 5 - 20%

### Exceptions to the warranty policies

- Under no circumstance shall the owner be entitled to recover costs for incidental, special or consequential damages such as, but not limited to: loss of profit or revenue, other commercial losses, inconvenience and/or replacement equipment rental cost.
- Maintenance, repair or service items not related to warrantable defects.
- Loss or damage during shipping.
- Failure resulting from lack of or improper maintenance.
- Damage caused by operator abuse, negligence or improper operation.
- Damage resulting from improper voltage supply.
- Damage from improper installation. Installation done by other than the manufacturer.
- Non-defective items replaced at the request of the customer.
- Damage due to accidents.
- Damage resulting from improper fuel supply (i.e. pressure or contamination).
- Damage resulting from cracked or broken lines occurring during transport.
- Damage resulting from use of inadequate or improper fluids (i.e. Glycol or oil).

## Owners obligations

- It is the responsibility of the owner, at the owner's expense, to transport the equipment to the service facility of an authorized DRYAIR distributor/dealer or alternately to reimburse the distributor/dealer, for any traveling expenses incurred in fulfilling this warranty.
- The terms of this Warranty Policy are subject to provincial and state legislation. DRYAIR reserves the right to make modifications in accordance with provincial and state legislation without prior notice or obligation.
- It is the responsibility of the owner to read, understand and implement the maintenance, safety and operational guidelines as laid out in the Operation and Maintenance Guide.
- All parts to be tagged with warranty claim number and shipped prepaid to DRYAIR within 30 days.

## Manufacture obligations

- DRYAIR reserves the right to continually improve the product's parts or specifications at any time without notice or obligation.
- The terms of this Warranty Policy are subject to provincial and state legislation. DRYAIR reserves the right to make modifications in accordance with provincial and state legislation without prior notice or obligation.

## Warranty Claim Procedure

- All warranty credits must be processed with the DRYAIR Warranty Claim Form.
- All warranty parts, unless otherwise specified, are to be returned to DRYAIR along with a completed Warranty Claim Form.

**Note: Prior to returning warranty parts, please call for an authorization number and shipping instructions from the Warranty department in Canada.**

Location of Warranty Depot :

DRYAIR Manufacturing Corp.  
400 Service Road, PO Box 126  
St. Brieux, Sk, Canada  
S0K 3V0  
Ph. 1 (888) 750-1700

- Each warranty claim should only refer to one Serial or Production Schedule numbered unit.
- Warranty parts are to be tagged with warranty claim number.
- When claiming for warranty labour, the allowable warranty labour rate will be \$65.00/hour. The factory reserves the right to adjust the number of hours claimed where deemed necessary.
- The factory may at times specify allowable labour for certain warranty procedures.
- Mileage and travel time, to and from the customer are not eligible for warranty credit.
- Freight charges for warranty parts are not eligible for warranty credit.
- Labour flat rates for component changes
  - Electrical components - 0.5 hour
  - Plumbing components - 1 hour
  - Electric motor changes - 1 hour

**Note: Other labour charges will be at the discretion of DRYAIR.**

# Safety Concerns

## General Safety Guidelines

- Make certain that the operator reads and understands all the information in this manual.



- All unauthorized people must be kept away from the equipment when in operation.
- Maintain instructional and safety decals. Replace damaged decals.
- All guards must be in place when the equipment is in operation.

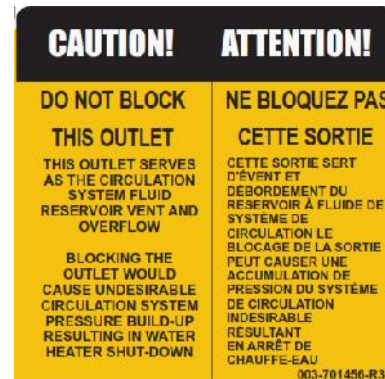
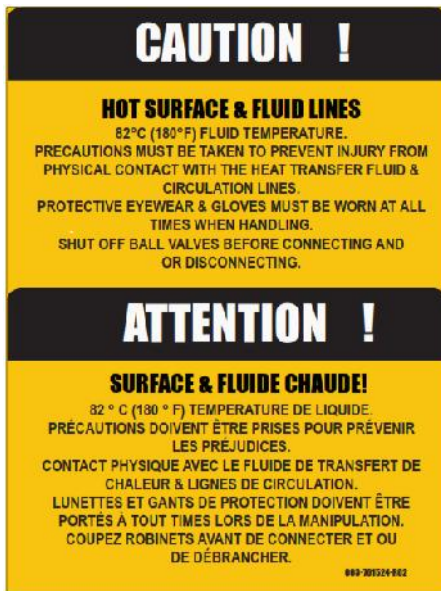

## **Water Heater Module**

CAUTION! The water heater is a heating appliance.

- When dealing with any heating appliance, observe all posted warnings and cautions.
- Keep children and pets away from all piping and fuel accessories.
- The water heater housing panels must be kept closed when the system is operating. This prevents drafts from affecting water heater operation.

## **Heat Transfer Fluid**

For complete "heat transfer fluid" information, refer to the Material Safety Data Sheets for "Dowfrost HTF" & "Boss Chill PG" in this section.



## MATERIAL SAFETY DATA SHEET

### SECTION 1: CHEMICAL PRODUCT AND COMPANY IDENTIFICATION

**PRODUCT NAME:** BOSS CHILL PROPYLENE GLYCOL  
 PROPYLENE-GLYCOL BASED  
 Heat Transfer Fluid Concentrate

**Date Prepared:** Sept 19, 2014

### COMPANY IDENTIFICATION

**Supplier:** BOSS LUBRICANTS  
 112, 6303 – 30 STREET SE  
 Calgary, AB T2C 1R4

**Telephone:** 403-279-2223

**Fax:** 403-279-2272

**Toll Free:** 800-844-9457

#### National Fire Protection Association

1	Health
1	Flammability
0	Reactivity
	Special



**Product Name:** BOSS CHILL PROPYLENE GLYCOL

**Product Description:** Propylene Glycol based industrial coolant and/or heat transfer fluid

**Chemical Name:** Inhibited propylene glycol, aqueous solution

**Chemical Family:** Mixture

**Formula:** Mixture

**Synonyms:** Heat transfer fluid, coolant

**DOT Identification:** Not regulated

**DOT Shipping No.:** Not regulated

**Manufacturer:** BOSS LUBRICANTS

### SECTION 2: TYPICAL COMPOSITION

<u>Material</u>	<u>CAS No</u>	<u>%Wt</u>
-----------------	---------------	------------





Propylene Glycol	000057-55-6	96%
Proprietary inhibitors	Not applicable	4%
Deionized Water	007732-18-5	Balance

This document is prepared pursuant to the OSHA Hazard Communication Standard (29 CFR 1910.122). In addition, other substances not "Hazardous" per this OSHA Standard may be listed. Where proprietary ingredients shows, the identity may be made available as provided in this standard.

**BOSS CHILL PROPYLENE GLYCOL  
BOSS LUBRICANTS: MATERIAL SAFETY DATA SHEET**

**SECTION 3: HAZARDOUS IDENTIFICATION**

**Health:** 2  
**Flammability:** 0  
**Reactivity:** 0  
**Special:** 0  
 0 = minimal 1 = slight 2 = moderate 3 = serious 4 = severe

HMIS
H # 2
F # 0
R # 0
PPE†
†Sec.8

**ROUTE(S) of Entry**

**Inhalation** A single prolonged (hours) inhalation exposure is not likely to cause adverse effects. Mists in high concentrations may cause irritation of nose and throat, cause headache, nausea or drowsiness. Prolonged or repeated exposure may result in the absorption of potentially harmful amounts of material.

**Skin:** A single prolonged exposure is not likely to result in the material being absorbed through skin in harmful amounts. Repeated exposure may cause slight flaking, tenderness and softening of skin.

**Ingestion:** Single dose oral toxicity is low. If more than several mouthfuls are swallowed, abdominal discomfort, nausea or diarrhea may occur

**Eyes:** May cause minor irritation of eyes in some individuals. Corneal injury is unlikely.

**Target Organs:** None known

**Effect of overexposure:** Repeated excessive ingestion may cause central nervous system effects. No carcinogenic effects have been seen in long-term animal studies. Birth defects are unlikely. Exposure having no adverse effects on the mother should have no effect



on the fetus. In animal studies, it has been shown not to interfere with reproduction. Results of mutagenicity tests in-vitro (test tube) and in animals have been negative.

**Signs and Symptoms of Exposure:**

Redness and/or stinging sensation in eyes or on skin. Minor eye or skin irritation may occur with some people.

**Medical conditions Generally Aggravated by**

**Long-Term Exposure:**

**Chronic Effects:** None known.

**Carcinogenicity**

**NTP:** None known

**IARC Monographs:** None known

**OSHA regulations:** None known

**ACGIH** None known

**SECTION 4: FIRST AID MEASURES**

**Emergency and First Aid Procedures**

**Eye Contact:** Flush eyes with large amounts of water for 15 minutes. If irritation persists, get medical attention.

**Skin Contact:** Wash off in flowing water or shower. Wash contaminated clothing before reuse.

**Ingestion:** DO NOT induce vomiting immediately and GET IMMEDIATE MEDICAL ATTENTION.

Never give anything by mouth to an unconscious person.

**Inhalation:** Remove to fresh air. If breathing has stopped, start artificial respiration. Seek medical attention.

**Note to Physicians:** Treat symptomatically. No specific antidote. Supportive care. Treatment based on judgment of physician in response to reactions of the patient.

**Special Precautions/**

**Procedure.** None known

**SECTION 5: FIRE-FIGHTING MEASURES**

**NFPA**

**Flash Point:** None

**Flash Point Method:** Not applicable

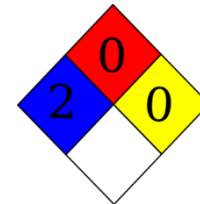

**Autoignition**

**Burning Rate:** Not available  
**Temperature:** Not available  
**Flammable limits in air (% by Volume)**  
**LEL:** Not available  
**UEL:** Not available

**Extinguishing Media:** Water for, fog, foam, CO2, dry chemical. Alcohol resistant foams (ATC type) are best when available. Do not use direct water stream as it may spread the fire.

**Unusual Fire or Explosion** Closed containers may rupture or explode due to steam pressure build-up when exposed to extreme heat.

**Hazards:** Water may be used to cool closed containers. Do not use a direct water stream on fire. Container may rupture from gas generation in a fire situation.

**Fire-Fighting Instructions:** Do not release runoff from fire control methods to sewers or waterways.

**Fire Fighting Equipment:** Full protective equipment including positive-pressure, self-contained breathing apparatus. During emergency conditions, overexposure to decomposition products may cause a health hazard. Symptoms may not be immediately apparent. Seek medical attention.

**Unusual Fire Fighting** Keep people out of the area and isolate fire. Burning liquids may be moved by flushing with water.

**Procedures:** Do not use a direct water stream as it may spread fire.

**SECTION 6: ACCIDENTAL RELEASE MEASURES**

**Spill/Leak Procedures:** Recover useable material by convenient method; residual may be removed by wipe or wet mop.

**Small Spills** Small spills should be absorbed with a suitable inert material (sand, earth, clay, etc.) Remove the absorbed material and place in an appropriate chemical waste container for disposal.

**Large Spills:** Large spills should be diked and pumped.

**Containment:** For large spills, dike far ahead of liquid spill for later disposal.

**Regulatory Requirements:** Follow applicable OSHA REGULATIONS (29 CFR 1910.120).



## SECTION 7: HANDLING AND STORAGE

- Handling Procedures:** Wear impermeable gloves and other protective clothing to avoid prolonged or repeated skin contact. When handling, wear eye protection.
- Storage Requirements:** Keep containers tightly closed when not in use. Store only in containers resistant to alkaline solutions with a pH of 9.0-12.0.

## SECTION 8: EXPOSURE CONTROLS/PERSONAL PROTECTION

- Exposure Guidelines:** Propylene Glycol: AIHA WEEL is 50 ppm total, 10mg/m<sup>3</sup> aerosol only. 10mg.m<sup>3</sup> for Propylene Glycol mist, 400ppm for Propylene Glycol vapors.
- Ventilation:** Provide general or local exhaust ventilation systems.
- Administrative Controls**
- Respiratory Protection:** If personal exposure cannot be controlled below applicable exposure limits by ventilation, wear respiratory devices approved by NIOSH/MSHA, for protection against organic vapors, dust, fumes and mists.
- Protective Clothing/ Equipment:** Wear chemically protective gloves, boots, aprons, and gauntlets to prevent prolonged or repeated skin contact. Wear protective eyeglasses or chemical safety goggles.
- Work and Hygienic Practices:** Wash or rinse hands before touching eyes or contact lenses, and before eating.
- Safety Stations:** Make emergency eyewash stations, safety/quick-drench showers, and washing facilities available in work area.

## SECTION 9: PHYSICAL AND CHEMICAL PROPERTIES

- Appearance and odor:** dyed purple                      odor less
- Boiling point (760 mmHg):** 317°F 188°C
- Specific Gravity (water=1)** 1.040 - 1.060
- Solubility in Water (%by wt):** Complete
- pH:** 9.0 - 10.5
- Vapor Density) air=1):** <1.0
- Vapor Pressure:** 2.2mmHg

## SECTION 10: STABILITY AND REACTIVITY

- Stability:** Stable
- Polymerization:** Hazardous polymerization cannot occur
- Chemical Incompatibilities:** Oxidizing materials, strong acids
- Conditions to avoid:** Avoid contact with strong acids and strong oxidizers



**Hazardous decomposition Products:** Depends upon temperature, air supply and the presence of other materials

#### SECTION 11: TOXICOLOGICAL INFORMATION

**Eye Effects:** Irritating to eyes.  
**Skin Effects:** The LD50 for skin absorption in rabbits is >10,000 mg/kg.  
**Acute Inhalation Effects:** Significant vapors are only generated at elevated temperatures; may irritate nose and respiratory system.  
**Acute Oral Effects:** The oral LD50 for rats is 20,000-34,000 mg/kg.  
**Chronic Effects:** Liver and kidney damage in a 2 year rat feeding study using 1-2% Propylene Glycol  
Oral administration of very high doses of Propylene Glycol produced birth defects in laboratory animals.  
**Carcinogenicity:** None known  
**Mutagenicity:** Not mutagenic  
**Teratogenicity:** Not Teratogenic

#### SECTION 12: ECOLOGICAL INFORMATION

**Ecotoxicity:** Base primarily on data for the major components, product is practically non-toxic to aquatic organisms.  
**Irritation Index/Estimation of Irritation (Species):** Not determined.  
**Environmental Fate:** Decomposes to carbon, oxygen, nitrogen and water.  
**Environmental Degradation:** Biodegradable  
**Soil Absorption/Mobility:** Not determined

#### SECTION 13: DISPOSAL CONSIDERATIONS

**Waste disposal method;** Sanitary landfill or incinerate in approved facilities in accordance with local, state and federal regulations. Do not dump into any sewers, on the ground or into any body of water.  
**Disposal Regulatory** This product, if unused, does not meet the RCRA criteria for being identified as a hazardous waste by characteristics.  
**Requirements:**  
**Container Cleaning and Disposal:** Containers should be cleaned or residual product before disposal, and disposed of in accordance with all applicable laws and regulations.

#### SECTION 14: TRANSPORT INFORMATION

**DOT Shipping Name:** Not regulated  
**Shipping Symbols:** Not applicable  
**Hazard Class:** Not applicable **DOT**  
**Identification No.:** Not regulated



**Packing Group:** Not applicable  
**Label:** Not applicable  
**Special Provisions (172.102):** Not applicable

**Packaging Authorizations**

a) **Exceptions:** Not applicable  
b) **Non-bulk Packaging:** Not applicable  
c) **Bulk Packaging:** Not applicable

**Quantity Limitations**

a) **Passenger, Aircraft, or Railcar:** Not applicable  
b) **Cargo Aircraft Only:** Not applicable

**Vessel Stowage Requirements**

a) **Vessel Stowage:** Not applicable  
b) **Other:** Not applicable

**SECTION 15: REGULATORY INFORMATION**

**Regulatory Information:** **Notice:** The information herein is presented in good faith and believed to be as accurate as the effective date shown above. However, no warranty, expressed or implied, is given. Regulatory requirements are subject to change and may differ from one location to another. It is the buyer's responsibility to ensure that its activities comply with federal, state or provincial and local laws. The following specific information is made for the purpose of complying with numerous federal, state or provincial, and local laws and regulations

(Not meant to be all-inclusive -selected regulations represented.)

**EPA Regulations**

RCRA Hazardous Waste Number and RCRA  
Hazardous Waste Classification: Not applicable  
CERCLA Hazardous Substance and CERCLA Reportable Quantity: Not applicable

SARA313: To the best of our knowledge this product contains no chemical subject to SARA TITLE 111 Section 313 supplier notification requirements

SARA Hazard Category: This product has been reviewed according to the EPA "Hazard Categories promulgated under Section 311 and 312 of the Superfund Amendment and



Re-Authorization Act of 1986 (SARA Title III) and is considered, under applicable definitions not to have met any hazard category.

**OSHA regulations:**

This product is not a "Hazardous Chemical" as defined by the OSHA Hazard Communication Standard, 29 CFR 1910.1200

**WHMIS:**

(The Canadian Workplace Materials Information System)

Not a "Controlled Product" under WHMIS Subdivision B (A toxic material causing other chronic effects) Hazardous

**SECTION 16 OTHER INFORMATION**

**Additional Hazard Rating Systems:** None

**Disclaimer: THE INFORMATION GIVEN HEREIN IS GIVEN IN GOOD FAITH AND FROM SOURCES WE BELIEVE RELIABLE. BUT NO WARRANTY, EXPRESS OR IMPLIED, REGARDING ITS CORRECTNESS IS MADE.**

The conditions or methods of handling, storage, use and disposal of this product are beyond our control and may be beyond our knowledge. For this and other reasons, we do not assume responsibility and expressly disclaim liability for loss, damage or expense arising out of or in any way connected with the handling, storage, use or disposal of this product.

This MSDS was prepared and is to be used only for this product. If the product is used as a component in another product, this MSDS information may not apply.

**CONSULT COMPANY LISTED IN SECTION 1 FOR FURTHER INFORMATION.**



# Material Safety Data Sheet

## DOW CHEMICAL CANADA ULC

Product name: DOWFROST™ Heat Transfer Fluid

Issue Date: 01/23/2015

Print Date: 06/29/2015

DOW CHEMICAL CANADA ULC encourages and expects you to read and understand the entire (M)SDS, as there is important information throughout the document. We expect you to follow the precautions identified in this document unless your use conditions would necessitate other appropriate methods or actions.

---

## 1. PRODUCT AND COMPANY IDENTIFICATION

---

Product name: DOWFROST™ Heat Transfer Fluid

### Recommended use of the chemical and restrictions on use

**Identified uses:** Intended as a heat transfer fluid for closed-loop systems. This product is acceptable for use where there is possibility of incidental food contact and as a product for use in the immersion or spray freezing of wrapped meat and packaged poultry products. We recommend that you use this product in a manner consistent with the listed use. If your intended use is not consistent with the stated use, please contact your sales or technical service representative.

### COMPANY IDENTIFICATION

DOW CHEMICAL CANADA ULC  
SUITE 2100  
450 - 1<sup>ST</sup> STREET S.W.  
CALGARY AB T2P 5H1  
CANADA

**For MSDS Updates and Product Information:** 800-258-2436

**Prepared by:** Prepared for use in Canada by EH&S, Hazard Communications.

**Revision Date:** 01/23/2015

**Print Date:** 06/29/2015

**Customer Information Number:**

800-258-2436

[SDSQuestion@dow.com](mailto:SDSQuestion@dow.com)

### EMERGENCY TELEPHONE NUMBER

**24-Hour Emergency Contact:** 989-636-4400

**Local Emergency Contact:** 613-996-6666

---

## 2. HAZARDS IDENTIFICATION

---

### Emergency Overview

#### Appearance

Physical state                      Liquid.

Color                                      Colorless

**Odor**                                      Characteristic



**Hazard Summary**

No significant immediate hazards for emergency response are known.

**Potential Health Effects**

**Eyes:** May cause slight temporary eye irritation.  
Corneal injury is unlikely.

**Skin:** Prolonged contact is essentially nonirritating to skin.  
Repeated contact may cause flaking and softening of skin.  
Prolonged skin contact is unlikely to result in absorption of harmful amounts.

**Inhalation:** At room temperature, exposure to vapor is minimal due to low volatility.  
Mist may cause irritation of upper respiratory tract (nose and throat).

**Ingestion:** Very low toxicity if swallowed.  
Harmful effects not anticipated from swallowing small amounts.

**Chronic Exposure:** In rare cases, repeated excessive exposure to propylene glycol may cause central nervous system effects.

---

**3. COMPOSITION/INFORMATION ON INGREDIENTS**

---

**Chemical nature:** Glycol  
This product is a mixture.

<b>Component</b>	<b>CASRN</b>	<b>Weight percent</b>
Propylene glycol	57-55-6	> 95.0 %
Dipotassium hydrogen phosphate	7758-11-4	< 3.0 %
Water	7732-18-5	< 3.0 %

---

**4. FIRST AID MEASURES**

---

**Description of first aid measures**

**General advice:** If potential for exposure exists refer to Section 8 for specific personal protective equipment.

**Inhalation:** Move person to fresh air; if effects occur, consult a physician.

**Skin contact:** Wash off with plenty of water.

**Eye contact:** Flush eyes thoroughly with water for several minutes. Remove contact lenses after the initial 1-2 minutes and continue flushing for several additional minutes. If effects occur, consult a physician, preferably an ophthalmologist.

**Ingestion:** No emergency medical treatment necessary.

**Most important symptoms and effects, both acute and delayed:** Aside from the information found under Description of first aid measures (above) and Indication of immediate medical attention and special treatment needed (below), any additional important symptoms and effects are described in Section 11: Toxicology Information.

**Indication of any immediate medical attention and special treatment needed**

**Notes to physician:** No specific antidote. Treatment of exposure should be directed at the control of symptoms and the clinical condition of the patient.

---

## **5. FIREFIGHTING MEASURES**

---

**Suitable extinguishing media:** Water fog or fine spray. Dry chemical fire extinguishers. Carbon dioxide fire extinguishers. Foam. Alcohol resistant foams (ATC type) are preferred. General purpose synthetic foams (including AFFF) or protein foams may function, but will be less effective.

**Unsuitable extinguishing media:** Do not use direct water stream. May spread fire.

**Special hazards arising from the substance or mixture**

**Hazardous combustion products:** During a fire, smoke may contain the original material in addition to combustion products of varying composition which may be toxic and/or irritating. Combustion products may include and are not limited to: Carbon monoxide. Carbon dioxide.

**Unusual Fire and Explosion Hazards:** Container may rupture from gas generation in a fire situation. Violent steam generation or eruption may occur upon application of direct water stream to hot liquids.

**Advice for firefighters**

**Fire Fighting Procedures:** Keep people away. Isolate fire and deny unnecessary entry. Use water spray to cool fire exposed containers and fire affected zone until fire is out and danger of reignition has passed. Fight fire from protected location or safe distance. Consider the use of unmanned hose holders or monitor nozzles. Immediately withdraw all personnel from the area in case of rising sound from venting safety device or discoloration of the container. Burning liquids may be extinguished by dilution with water. Do not use direct water stream. May spread fire. Move container from fire area if this is possible without hazard. Burning liquids may be moved by flushing with water to protect personnel and minimize property damage.

**Special protective equipment for firefighters:** Wear positive-pressure self-contained breathing apparatus (SCBA) and protective fire fighting clothing (includes fire fighting helmet, coat, trousers, boots, and gloves). If protective equipment is not available or not used, fight fire from a protected location or safe distance.

---

## **6. ACCIDENTAL RELEASE MEASURES**

---

**Personal precautions, protective equipment and emergency procedures:** Use appropriate safety equipment. For additional information, refer to Section 8, Exposure Controls and Personal Protection.

**Environmental precautions:** Prevent from entering into soil, ditches, sewers, waterways and/or groundwater. See Section 12, Ecological Information.

**Methods and materials for containment and cleaning up:** Small spills: Absorb with materials such as: Cat litter. Sawdust. Vermiculite. Zorb-all®. Collect in suitable and properly labeled containers. Large spills: Dike area to contain spill. Recover spilled material if possible. See Section 13, Disposal Considerations, for additional information.

## 7. HANDLING AND STORAGE

**Precautions for safe handling:** No special precautions required. Keep container closed. See Section 8, EXPOSURE CONTROLS AND PERSONAL PROTECTION.

Spills of these organic materials on hot fibrous insulations may lead to lowering of the autoignition temperatures possibly resulting in spontaneous combustion.

**Conditions for safe storage:** Do not store in: Galvanized steel. Opened or unlabeled containers. Store in original unopened container. See Section 10 for more specific information. Additional storage and handling information on this product may be obtained by calling your sales or customer service contact.

## 8. EXPOSURE CONTROLS/PERSONAL PROTECTION

### Control parameters

Exposure limits are listed below, if they exist.

Component	Regulation	Type of listing	Value/Notation
Propylene glycol	US WEEL	TWA	10 mg/m <sup>3</sup>
	CA ON OEL	TWAEV Total	155 mg/m <sup>3</sup> 50 ppm
	CA ON OEL	TWAEV	10 mg/m <sup>3</sup>
	CA ON OEL	TWA	155 mg/m <sup>3</sup> 50 ppm
	CA ON OEL	TWA	10 mg/m <sup>3</sup>

Consult local authorities for recommended exposure limits.

### Exposure controls

**Engineering controls:** Use local exhaust ventilation, or other engineering controls to maintain airborne levels below exposure limit requirements or guidelines. If there are no applicable exposure limit requirements or guidelines, general ventilation should be sufficient for most operations. Local exhaust ventilation may be necessary for some operations.

### Individual protection measures

**Eye/face protection:** Use safety glasses (with side shields).

#### Skin protection

**Hand protection:** Use gloves chemically resistant to this material when prolonged or frequently repeated contact could occur. Examples of preferred glove barrier materials include: Butyl rubber. Natural rubber ("latex"). Neoprene. Nitrile/butadiene rubber ("nitrile" or "NBR"). Polyethylene. Ethyl vinyl alcohol laminate ("EVAL"). Polyvinyl alcohol ("PVA"). Polyvinyl chloride ("PVC" or "vinyl"). NOTICE: The selection of a specific glove for a particular application and duration of use in a workplace should also take into account all relevant workplace factors such as, but not limited to: Other chemicals which may be handled, physical requirements (cut/puncture protection, dexterity, thermal protection), potential body reactions to glove materials, as well as the instructions/specifications provided by the glove supplier.

**Other protection:** Wear clean, body-covering clothing.

**Respiratory protection:** Respiratory protection should be worn when there is a potential to exceed the exposure limit requirements or guidelines. If there are no applicable exposure limit requirements or guidelines, wear respiratory protection when adverse effects, such as respiratory irritation or discomfort have been experienced, or where indicated by your risk assessment process. In misty atmospheres, use an approved particulate respirator. The following should be effective types of air-purifying respirators: Organic vapor cartridge with a particulate pre-filter.

---

## 9. PHYSICAL AND CHEMICAL PROPERTIES

---

### Appearance

Physical state	Liquid.
Color	Colorless
Odor	Characteristic
Odor Threshold	No test data available
pH	10.0 50% <i>Literature</i>
Melting point/range	Not applicable to liquids
Freezing point	supercools
Boiling point (760 mmHg)	152 °C <i>Literature</i>
Flash point	<b>closed cup</b> 104 °C <i>Pensky-Martens Closed Cup ASTM D 93</i> (based on major component), Propylene glycol. <b>open cup</b> <i>Cleveland Open Cup ASTM D92</i> None
Evaporation Rate (Butyl Acetate = 1)	<0.5 <i>Estimated.</i>
Flammability (solid, gas)	Not applicable to liquids
Lower explosion limit	2.6 % vol <i>Literature</i> Propylene glycol.
Upper explosion limit	12.5 % vol <i>Literature</i> Propylene glycol.
Vapor Pressure	2.2 mmHg <i>Literature</i>
Relative Vapor Density (air = 1)	>1.0 <i>Literature</i>
Relative Density (water = 1)	1.05 at 20 °C / 20 °C <i>Literature</i>
Water solubility	100 % <i>Literature</i>
Partition coefficient: n-octanol/water	no data available
Auto-ignition temperature	371 °C <i>Literature</i> Propylene glycol.
Decomposition temperature	No test data available
Kinematic Viscosity	43.4 cSt at 20 °C <i>Literature</i>
Explosive properties	no data available
Oxidizing properties	no data available
Molecular weight	76.9 g/mol <i>Literature</i>

NOTE: The physical data presented above are typical values and should not be construed as a specification.

---

---

## 10. STABILITY AND REACTIVITY

---

**Reactivity:** no data available

**Chemical stability:** Stable under recommended storage conditions. See Storage, Section 7.  
Hygroscopic

**Possibility of hazardous reactions:** Polymerization will not occur.

**Conditions to avoid:** Exposure to elevated temperatures can cause product to decompose. Generation of gas during decomposition can cause pressure in closed systems. Avoid direct sunlight or ultraviolet sources.

**Incompatible materials:** Avoid contact with: Strong acids. Strong bases. Strong oxidizers.

**Hazardous decomposition products:** Decomposition products depend upon temperature, air supply and the presence of other materials. Decomposition products can include and are not limited to: Aldehydes. Alcohols. Ethers. Organic acids.

---

---

## 11. TOXICOLOGICAL INFORMATION

---

*Toxicological information on this product or its components appear in this section when such data is available.*

### Acute toxicity

#### Acute oral toxicity

Very low toxicity if swallowed. Harmful effects not anticipated from swallowing small amounts.

For the major component(s): Propylene glycol.  
LD50, Rat, > 20,000 mg/kg

#### Acute dermal toxicity

Prolonged skin contact is unlikely to result in absorption of harmful amounts.

For the major component(s): Propylene glycol.  
LD50, Rabbit, > 20,000 mg/kg

#### Acute inhalation toxicity

At room temperature, exposure to vapor is minimal due to low volatility. Mist may cause irritation of upper respiratory tract (nose and throat).

For the major component(s):  
LC50, Rat, 4 Hour, vapour, 6.15 mg/l No deaths occurred following exposure to a saturated atmosphere.

### Skin corrosion/irritation

Prolonged contact is essentially nonirritating to skin.  
Repeated contact may cause flaking and softening of skin.

**Serious eye damage/eye irritation**

May cause slight temporary eye irritation.  
Corneal injury is unlikely.

**Sensitization**

For the major component(s):  
Did not cause allergic skin reactions when tested in humans.

For respiratory sensitization:  
No relevant data found.

**Specific Target Organ Systemic Toxicity (Single Exposure)**

Evaluation of available data suggests that this material is not an STOT-SE toxicant.

**Specific Target Organ Systemic Toxicity (Repeated Exposure)**

In rare cases, repeated excessive exposure to propylene glycol may cause central nervous system effects.

**Carcinogenicity**

Similar formulations did not cause cancer in laboratory animals.

**Teratogenicity**

For the major component(s): Did not cause birth defects or any other fetal effects in laboratory animals.

**Reproductive toxicity**

For the major component(s): In animal studies, did not interfere with reproduction. In animal studies, did not interfere with fertility.

**Mutagenicity**

In vitro genetic toxicity studies were negative. For the major component(s): Animal genetic toxicity studies were negative.

**Aspiration Hazard**

Based on physical properties, not likely to be an aspiration hazard.

---

---

**12. ECOLOGICAL INFORMATION**

---

---

*Ecotoxicological information on this product or its components appear in this section when such data is available.*

**Toxicity**

**Propylene glycol**

**Acute toxicity to fish**

Material is practically non-toxic to aquatic organisms on an acute basis (LC50/EC50/EL50/LL50 >100 mg/L in the most sensitive species tested).  
LC50, *Oncorhynchus mykiss* (rainbow trout), static test, 96 Hour, 40,613 mg/l, OECD Test Guideline 203

**Acute toxicity to aquatic invertebrates**

LC50, Ceriodaphnia dubia (water flea), static test, 48 Hour, 18,340 mg/l, OECD Test Guideline 202

**Acute toxicity to algae/aquatic plants**

ErC50, Pseudokirchneriella subcapitata (green algae), 96 Hour, Growth rate inhibition, 19,000 mg/l, OECD Test Guideline 201

**Toxicity to bacteria**

NOEC, Pseudomonas putida, 18 Hour, > 20,000 mg/l

**Chronic toxicity to aquatic invertebrates**

NOEC, Ceriodaphnia dubia (water flea), semi-static test, 7 d, number of offspring, 13,020 mg/l

**Dipotassium hydrogen phosphate**

**Acute toxicity to fish**

Material is practically non-toxic to aquatic organisms on an acute basis (LC50/EC50/EL50/LL50 >100 mg/L in the most sensitive species tested).  
LC50, Leuciscus idus (Golden orfe), static test, 48 Hour, > 900 mg/l, Method Not Specified.

**Persistence and degradability**

**Propylene glycol**

**Biodegradability:** Material is readily biodegradable. Passes OECD test(s) for ready biodegradability. Biodegradation may occur under anaerobic conditions (in the absence of oxygen).

10-day Window: Pass

**Biodegradation:** 81 %

**Exposure time:** 28 d

**Method:** OECD Test Guideline 301F or Equivalent

10-day Window: Not applicable

**Biodegradation:** 96 %

**Exposure time:** 64 d

**Method:** OECD Test Guideline 306 or Equivalent

**Theoretical Oxygen Demand:** 1.68 mg/mg

**Chemical Oxygen Demand:** 1.53 mg/mg

**Biological oxygen demand (BOD)**

Incubation Time	BOD
5 d	69.000 %
10 d	70.000 %
20 d	86.000 %

**Photodegradation**

**Atmospheric half-life:** 10 Hour

**Method:** Estimated.

**Dipotassium hydrogen phosphate**

**Biodegradability:** Biodegradation is not applicable.

**Bioaccumulative potential**

**Propylene glycol**

**Bioaccumulation:** Bioconcentration potential is low (BCF < 100 or Log Pow < 3).

**Partition coefficient: n-octanol/water(log Pow):** -1.07 Measured

**Bioconcentration factor (BCF):** 0.09 Estimated.

**Dipotassium hydrogen phosphate**

**Bioaccumulation:** No bioconcentration is expected because of the relatively high water solubility.

**Mobility in soil**

**Propylene glycol**

Given its very low Henry's constant, volatilization from natural bodies of water or moist soil is not expected to be an important fate process.

Potential for mobility in soil is very high (Koc between 0 and 50).

**Partition coefficient(Koc):** < 1 Estimated.

**Dipotassium hydrogen phosphate**

No relevant data found.

---

---

### **13. DISPOSAL CONSIDERATIONS**

---

**Disposal methods:** DO NOT DUMP INTO ANY SEWERS, ON THE GROUND, OR INTO ANY BODY OF WATER. All disposal practices must be in compliance with all Federal, State/Provincial and local laws and regulations. Regulations may vary in different locations. Waste characterizations and compliance with applicable laws are the responsibility solely of the waste generator. AS YOUR SUPPLIER, WE HAVE NO CONTROL OVER THE MANAGEMENT PRACTICES OR MANUFACTURING PROCESSES OF PARTIES HANDLING OR USING THIS MATERIAL. THE INFORMATION PRESENTED HERE PERTAINS ONLY TO THE PRODUCT AS SHIPPED IN ITS INTENDED CONDITION AS DESCRIBED IN MSDS SECTION: Composition Information. FOR UNUSED & UNCONTAMINATED PRODUCT, the preferred options include sending to a licensed, permitted: Recycler. Reclaimer. Incinerator or other thermal destruction device.

---

---

### **14. TRANSPORT INFORMATION**

---

**TDG**

Not regulated for transport

**Classification for SEA transport (IMO-IMDG):**

Not regulated for transport

**Transport in bulk  
according to Annex I or II  
of MARPOL 73/78 and the  
IBC or IGC Code**

Consult IMO regulations before transporting ocean bulk

**Classification for AIR transport (IATA/ICAO):**

Not regulated for transport



This information is not intended to convey all specific regulatory or operational requirements/information relating to this product. Transportation classifications may vary by container volume and may be influenced by regional or country variations in regulations. Additional transportation system information can be obtained through an authorized sales or customer service representative. It is the responsibility of the transporting organization to follow all applicable laws, regulations and rules relating to the transportation of the material.

---

## 15. REGULATORY INFORMATION

---

### **Hazardous Products Act Information: CPR Compliance**

This product has been classified in accordance with the hazard criteria of the Canadian Controlled Products Regulations (CPR) and the MSDS contains all the information required by the CPR.

### **Hazardous Products Act Information: WHMIS Classification**

This product is not a “Controlled Product” under WHMIS.

### **Canadian Domestic Substances List (DSL) (DSL)**

All substances contained in this product are listed on the Canadian Domestic Substances List (DSL) or are not required to be listed.

---

## 16. OTHER INFORMATION

---

### **Hazard Rating System**

#### **NFPA**

Health	Fire	Reactivity
0	1	0

### **Revision**

Identification Number: 101234106 / A208 / Issue Date: 01/23/2015 / Version: 6.0

Most recent revision(s) are noted by the bold, double bars in left-hand margin throughout this document.

### **Legend**

CA ON OEL	Canada. Ontario OELs
TWA	8-hr TWA
TWAEV	time-weighted average exposure value
US WEEL	USA. Workplace Environmental Exposure Levels (WEEL)

### **Information Source and References**

This SDS is prepared by Product Regulatory Services and Hazard Communications Groups from information supplied by internal references within our company.

DOW CHEMICAL CANADA ULC urges each customer or recipient of this (M)SDS to study it carefully and consult appropriate expertise, as necessary or appropriate, to become aware of and understand

the data contained in this (M)SDS and any hazards associated with the product. The information herein is provided in good faith and believed to be accurate as of the effective date shown above. However, no warranty, express or implied, is given. Regulatory requirements are subject to change and may differ between various locations. It is the buyer's/user's responsibility to ensure that his activities comply with all federal, state, provincial or local laws. The information presented here pertains only to the product as shipped. Since conditions for use of the product are not under the control of the manufacturer, it is the buyer's/user's duty to determine the conditions necessary for the safe use of this product. Due to the proliferation of sources for information such as manufacturer-specific (M)SDSs, we are not and cannot be responsible for (M)SDSs obtained from any source other than ourselves. If you have obtained an (M)SDS from another source or if you are not sure that the (M)SDS you have is current, please contact us for the most current version.

# Introduction

## Components

### Central Mobile Enclosure (CME)

- A compact and portable design.
- Easy access from rear and side doors.
- Automatic temperature control and fuel usage which responds to work site demands.
- Low pressure atmospherically vented circulation system ... no special boiler certification is required to operate the system.
- Circulation system "automatic air vent" component for quick setup-and-go operation.
- A central heat module control center which monitors and controls system operations.
- A multi-light system operation feature for easy system troubleshooting.
- Flow-reversing "Green Thaw" system.



1 - GTS 300 Central Mobile Enclosure (side view)



2 - GTS 300 Central Mobile Enclosure (back view)

## Passive heat transfer

### Circulation line heat exchangers

The circulation line heat exchangers are the perfect solution for:

- Heating and/or thawing cold or frozen ground.
- Frost prevention.
- Concrete curing and heating in subzero environments.

This system can be applied to all types of concrete applications. Circulation line heat exchangers can be secured directly against the surface of the concrete or concrete forms. Alternately, an expendable circulation line can be incorporated into the concrete structure during the pour. Thus the slab floor can continue being heated, to provide radiant floor heat during construction.

### Hose reel

- The on board hose reel comes with 3000ft. of 5/8" I.D circulation line heat exchanger hose.
- The reel provides convenient storage for the "circulation line heat exchange" hose required for thawing and/or curing concrete.
- The electric drive system provides "power on" or "power off" capability.
- A torque-limiting device provides breaking.
- The on-board reel comes with an integral 6-port manifold and a pair of 1 1/4" quick connections to accommodate a remote manifold.



3 - Hose reel

## Accessories

### Mixing/booster pump

The multifunctional mixing/booster ensures maximum flexibility in the use of this system.

- Tempering mode supplies lower temperature fluid for concrete cure and radiant floor heat applications eliminating the need to reduce the water heater operating temperatures below safe operating ranges.
- When operating in booster mode, the system can increase flow rates or function as a pumping station to increase pumping distances by over 300 feet per station.
- The system also allows for dual-temperature control. High temperature fluid can be provided to portable heat exchangers, along with a lower temperature fluid for concrete cure and radiant floor heat applications.
- The multifunctional mixing/booster ensures maximum flexibility in the use of this system.



4 - Mixing/booster pump

### Optional remote manifold

- Allows for additional distribution and/or separation between the central heating trailer and the manifold.

### Insulated line jackets

Insulated circulation line jackets are also available. These insulated jackets will prevent exposed circulation line heat loss in extreme subzero conditions.



5 - Optional remote manifold & Fluid circulation lines

## Portable heat exchanger

Portable heat exchangers are the ideal way to heat and/or dry enclosed structures. Their compact and mobile design allows them to be positioned where required on the job site. The efficient fan/coil design provides a high rate of heat transfer. High volume fans then deliver this heat evenly throughout a large area. The clean, low relative humidity heat delivery minimizes energy costs by eliminating the need to draw in fresh outside air. With this system, you just reheat warm internal air, rather than heating cold external air.



6 - Portable Heat Exchangers

## How the system works

The system uses a low-pressure, open fluid loop distribution system with an atmospherically vented fluid reservoir. A central heating module warms the heat transfer fluid. This heated fluid is pumped through a distribution system loop, passing through heat exchangers in remote locations.

Two types of exchangers are available:

- Portable heat exchangers include a heat transfer coil, fan and thermostatic temperature control. The heat transfer fluid flows through the transfer coil, where heat is transferred to the air being drawn through the coil by the fan. The coil is specially designed for optimum heat transfer, without adding any moisture or combustion by-products to the air.
- Circulation line heat exchangers use flexible hose with hydraulic-style quick-couplers for ease in hookup. Heat transfer occurs by direct contact heat transfer and radiant heat conduction.

The mixing/booster unit can be utilized to:

- Provide lower temperature fluid for concrete cure and radiant floor heat applications.
- Provide dual temperature control with a single fluid circulation system.
- Boost fluid flow and increase pumping distances.

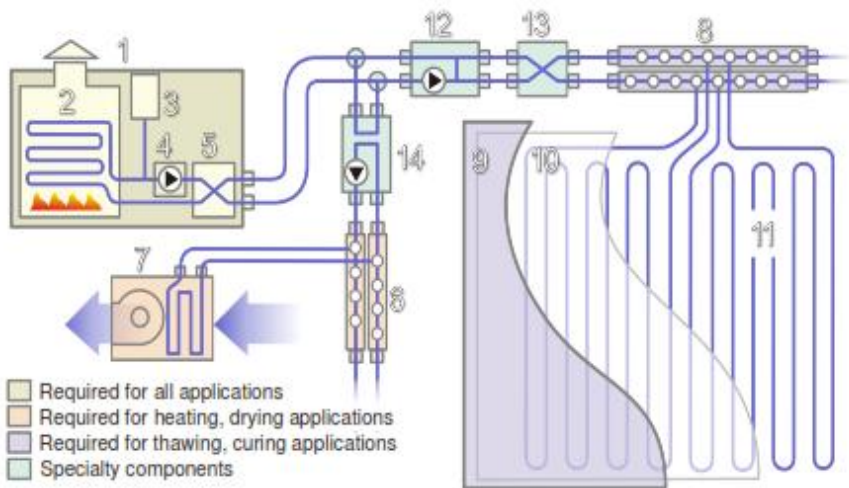

- Required for all applications
- Required for heating, drying applications
- Required for thawing, curing applications
- Specialty components

- |   |                                       |
|---|---------------------------------------|
| 1) Heat delivery system*                                | 8) HTF distribution manifold - 8-port |
| 2) Water heater   | 9) Insulated blankets                 |
| 3) HTF reservoir/atmospheric vent                       | 10) Vapor barrier                     |
| 4) Pump   | 11) Line heat exchangers              |
| 5) Flow reverser (built-in with greenthaw systems only) | 12) Mixing/booster                    |
| 6) HTF distribution manifold - 4-port                   | 13) Flow reverser (remote unit)       |
| 7) Powered heat exchanger (fluid-to-air exchange)       | 14) Plate heat exchanger              |

\*'Central heating module' (CHM - propane, nat gas or diesel fired) or 'steam plate heat exchanger'

# Setup (CME)

The positioning of all the system components on the site will be influenced by a number of factors. Please read all of the "Setup" section before beginning.

Be sure to observe all local electrical codes and fire regulations when positioning the central heat module.

## Required safety clearances

The GTS 300 is a heating appliance, therefore safe heat and exhaust clearances must be observed from combustible materials and for service access.

- Maintain 24" (61 cm) of clearance on all sides of the unit.
- Maintain 36" (91 cm) of clearance on all sides of the flue pipe and chimney cap

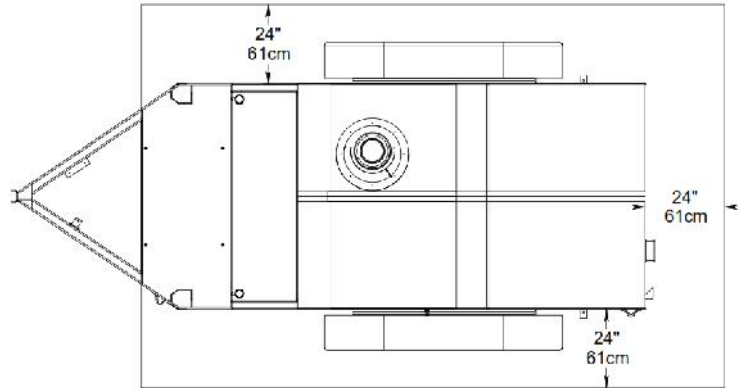

7 - GTS 300 top view

## Elevation concerns

Do not place any "portable heat exchangers" or "circulation line heat exchangers" higher than the top level of the heat transfer fluid fill tank without using a reservoir extension kit. If this is not observed, the following can occur:

- Insufficient fluid in the system.  
Fluid will drain back to the heat transfer fill tank from the over-elevated fluid lines when the pump is shut off. The heat transfer fill tank will show adequate fluid but, when the pump is started, extra fluid will be required to recharge the over-elevated fluid lines and portable heat exchangers and the system will then have insufficient fluid in the reservoir.
- Fluid overflow  
If fluid is added to maintain proper fluid levels while the pump is running, overflow at the fill tank will occur when the pump is shut off. This would occur because of drain back from the over-elevated fluid lines.

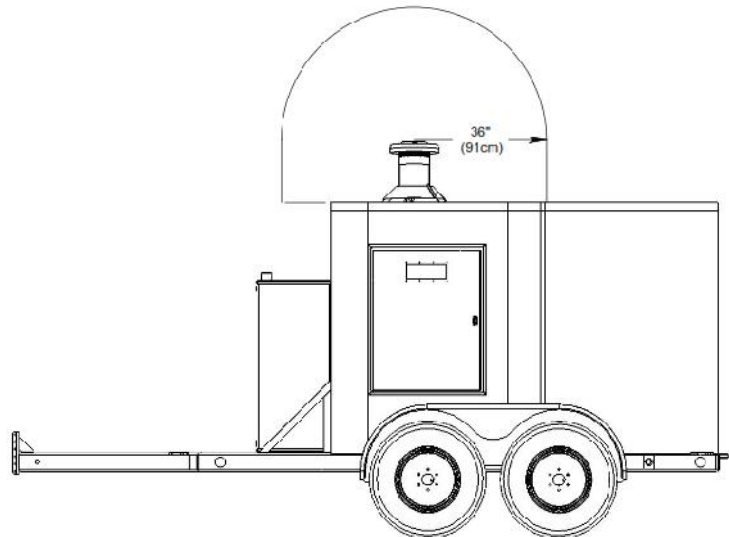

8 - GTS 300 side view

# Electrical requirements & connection

When determining the "central mobile enclosure" location on site, consider setting up in close proximity to the electrical power supply.

*Note: This applies mainly to systems not equipped with a dedicated generator.*

- The GTS 300's main feed wiring must be adequately sized to carry the minimum ampacity shown on the water heater cabinet's rating label. All electrical connections, connectors and wire must be CSA/UL compliant and installed according to local laws and codes.
- Before making any electrical connections, be sure that the power supply is "Off".

## GTS 300 Electrical Connection (Figure 9):

- The GTS 300 requires 115VAC single phase power. The module is factory wired so that only connection is made to an 115VAC service outlet. A 15 ft. main supply cord is included.
- The main feed wiring must be adequately sized to carry the minimum ampacity shown on the central heat module's rating label.
- All electrical connections, connectors and wire must be CSA/UL approved, and installed according to local laws and codes.
- A 3-wire hookup is required for all systems to work properly. Warranty is void if the wiring hookup is not done correctly.

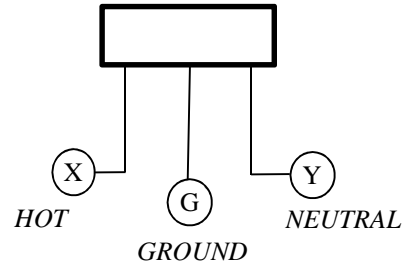

9-GTS 300 electrical hookup (115VAC)

# Heat transfer fluid "HTF"

**CAUTION!** At no time should you use automobile antifreeze in your system. The use of automobile antifreeze will void your warranty.

- The heat transfer fluid "HTF" level should show no more than 1/2 on the gauge (cold fluid) at start-up. As the "HTF" warms to operating temperature, fluid expansion will raise the level to 1/2 or 3/4 on the gauge (depending on the total volume of fluid in the circulation system).

## Heat transfer fluid specifications

- The system is shipped with pre-mixed "HTF", made up of 60% "Dowfrost ® HTF" or "Boss Chill PG" and 40% water\*, by weight - freeze protection down to -40°F (-40°C).
- The "glycol/water mixture chart", to the right, will provide you with more information on the proper mixture for your area. "Dowfrost ® HTF" or "Boss Chill PG" must be used. The pure "Dowfrost ® HTF" or "Boss Chill PG" heat transfer fluid used in the system is made up of a blend of 95-97% Propylene glycol, <5% Dipotassium phosphate and deionized water (see Safety Concerns section - MSDS sheets for additional information,
- Soft water with a neutral pH level (#7) must be used.

**CAUTION!** Whenever coupling or uncoupling quick couplers, make sure that the isolation valves are closed and the pump is off. Failure to do so may put you at risk of injury from eye and/or skin exposure to hot glycol.

Percent Propylene Glycol		Freezing Point	
By Mass	By Volume	F°	C°
0.0	0.0	32.0	0.0
10.0	9.6	26.1	-3.2
20.0	19.4	17.9	-7.8
30.0	29.4	6.7	-14.0
40.0	39.6	-8.1	-22.3
50.0	49.9	-28.9	-33.8
60.0	60.0	-54.9	-48.3

10 - glycol/water mixture chart

## Fuel

- Only clean #1 or #2 diesel fuel or light heating oil is suitable for use in the system.
- The "central heat module" comes equipped with its own tank, so there are no fuel line hookups required.
- The fuel system utilizes a two-pipe system to ensure efficient fuel supply to the burner.

*Contact your local fuel supplier to inform them of the requirements.*

## Primary "HTF" circulation lines

- If possible, position the primary circulation lines out of high traffic areas.
- If primary "HTF" circulation lines are required, connect the primary circulation lines to manifold "supply" and "return" kamlocks at the back of the central mobile enclosure. Quick couplers are attached to both ends of the primary circulation lines to enable quick coupling. This also allows the isolation of the primary lines while retaining the heat transfer fluid "HTF" in the lines. Plus ... setup and dismantling of the circulation system is much quicker.

## Burner Removal

To remove an existing **Riello model 40-F10 Diesel/Light Oil Burner**, use the following sequence:

1. Make certain that the power supply to the central heat module is disconnected.
2. Disconnect the electrical connection to the burner by disconnecting the # 1, #2 and green/yellow wires attached to the control box (11-1) on the burner assembly. Slip the water tight connection (11-2) from the burner chassis, located in the bottom right corner of the burner assembly.
3. Disconnect the oil supply hose (12-1) and oil return hose (12-2) by unscrewing the fuel line connections on the side of the burner. The loose supply and return hose ends should be plugged and pushed aside out of the way inside the cabinet. Mark hoses for correct reconnection.
4. Remove the fuel pressure line (11-3) from burner fuel pump.
5. Remove 2 bolts (13-1) from top of burner tube bracket.
6. Pull burner toward you and away from the mounting bracket (13-2).

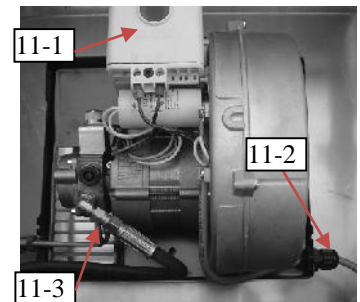

11 - Riello burner

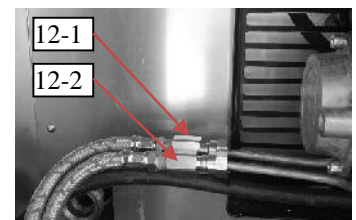

12-oil supply and return

## Burner Installation

To install a **Riello model 40-F10 Diesel/Light Oil Burner**:

1. Insert burner into the mounting bracket (13-2).
2. Install 2 bolts (13-1) at top of burner tube bracket.
3. Connect the oil supply hose (12-1) and oil return hose (12-2) by coupling them to the JIC connections on the side of the burner. Insure hoses are attached to correct connectors.
4. Connect the fuel pressure line (11-3) to the burner fuel pump.
5. Connect the electrical connection to the burner by connecting the # 1, #2 and the green/ yellow wires to the control box on the burner assembly (11-1). Once the wires have been reconnected, slip the water tight connection (11-2) into the burner chassis, located in the bottom right corner of the burner assembly.

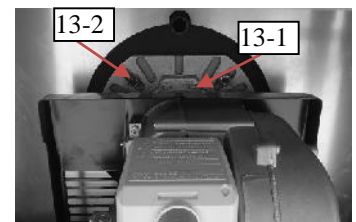

13-Riello burner tube and mounting bracket



# INITIAL SETTINGS FOR THE ACTUATOR MOTOR ON THE FLOW REVERSERS FOR THE GTS 300

*Step 1*



When setting actuators motor on the flow reverser for the first time the notch in the plastic sleeve should be set as indicated in this picture.

*Step 2*



The result should look like this when actuator motor is installed without cap. The actuator motor will have to be turned fully to one side.

*Step 3*



Install cap and turn until it falls down into position. This happens after 45° rotation of the actuator cap.

*Step 4*



After power is applied to the actuator, the valve will move into an operational position.

# Operation (CME)

## Purging air from the "HTF" circulation system

- Verify that the primary circulation lines are connected to a distribution manifold.
- Complete the connection for one "heat exchanger loop" or "portable heat exchanger" (14-1). This will complete the circulation loop and allow circulation.

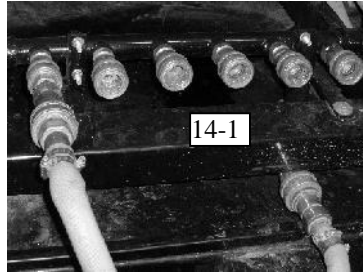

*14-“Supply” & “Return”  
isolation valve in the “open”*

- The automatic air vent (15-1) does not need adjustment.

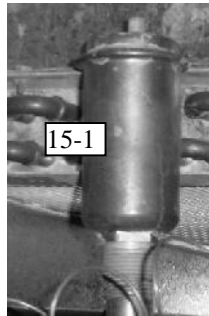

*15-Automatic air*

- Toggle the pump switch (16-1) to the "On"(up) position and run the pump. This will release the air from the system.

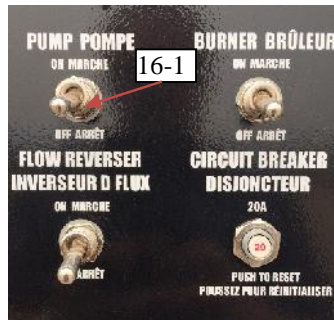

*16-pump, water heater &  
flow reverser switch*

- Monitor the "heat transfer fluid sight glass" (17-1) and make sure that the heat transfer fluid level stays between 1/4 to 1/2 full at all times during this process.
- Note that there may be a certain amount of air in the system. "HTF" levels may change as air is displaced from the system. Add "HTF" fluid to maintain 1/2 to 5/8 levels when the fluid is cold.

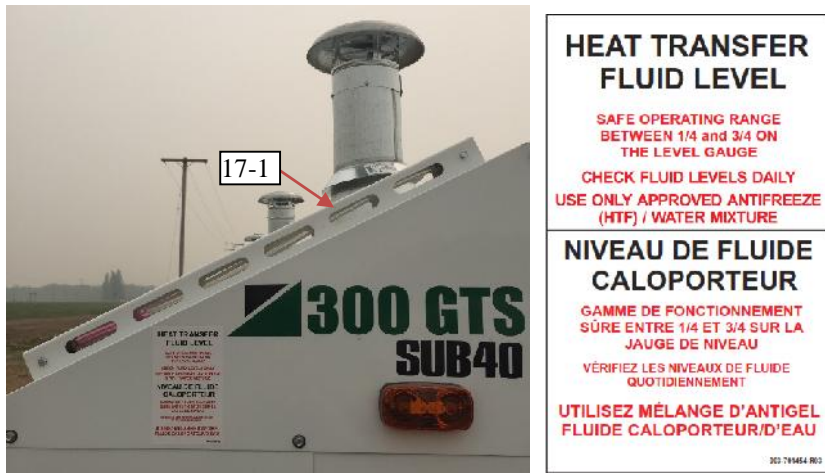

*17-heat transfer fluid sight glass*

- When the air is eliminated, the "System Pressure" gauge (18-1) will hold at a steady reading of between 15 to 40 P.S.I.



*18-system pressure gauge*

# Before firing the system

- Verify that the power supply is correct and that the electrical hook up is as specified in "Setup".
- Verify that the water heater is being supplied with the same fuel type as indicated on the water heater data plate "LIGHT OIL/DIESEL FUEL".



- Verify that the fuel line valves are in the correct positions.

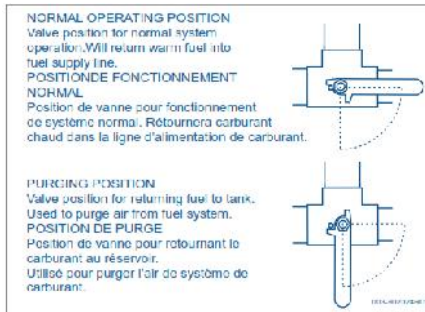

- Verify that the heat transfer fluid level gauge shows approximately 1/4 full.



## POWER SUPPLY

### 1 HOSE REEL

#### POWER SUPPLY CONNECTION

120 VAC 1PH  
3-WIRE NEMA 5-15

**NOTE:**

FOR NORMAL OPERATION OF WATER HEATER IN PRE-HEAT MODE WHILE OPERATING HOSE REEL, ONE DEDICATED 15A CIRCUIT MINIMUM IS REQUIRED.

FOR SIMULTANEOUS OPERATION OF WATER HEATER IN HEATING MODE AND HOSE REEL, TWO SEPARATE 15A CIRCUITS ARE NECESSARY.

Pour l'opération normale de chauffe-eau dans le mode de préchauffage normal tandis qu'il y a exploitation des rouleaux de tuyau, un minimum de circuit 15A spécialisé est requis.

Pour le fonctionnement de chauffe-eau dans le mode de chauffage et l'exploitation de rouleaux de tuyau, deux circuits 15A séparés sont nécessaires.

## 2 CENTRAL HEATING MODULE

801-502948

# Cold start procedure

This procedure must be completed if the ambient outdoor air temperature is lower than 50° F (10° C).

Consider initiating this process well in advance of firing the system

***In -30F (-34C) conditions, this process could take up to 6 hours.***

- The system has a built-in, electric "cold start" fluid pre-heater which will heat the "heat transfer fluid" in the water heater heat exchanger.
- Confirm that the pump switch (19-1) and water heater switch (19-2) are in the "Off" (down) position.
- This will automatically energize the electric "cold start" circulation heater.
- Wait until the "supply temperature gauge" (20-1) reads between 80° F to 100° F (60° C to 65° C). The time required for the heat transfer fluid in the heat exchanger to reach this temperature will depend on the outdoor ambient air temperature.
- Toggle the pump switch (19-1) located on the control panel to the "On" (up) position. Once the pump is turned on, the "cold start" fluid pre-heater is automatically shut off.
- With the pump on, the "heat transfer fluid" will circulate through the heat module's internal bypass system. This will supply warm "heat transfer fluid" to the combustion air and fuel preheat systems, which tempers combustion air and fuel for smooth burner start-up and operation.
- Continue circulating the "heat transfer fluid" within the heat module's distribution system until the "combustion air gauge" (20-2) and the "fuel temperature gauge" (20-3) read approximately 60° F to 70° F (15° C to 21 ° C).

***The time required for the combustion air and fuel to reach this temperature will again depend on the outdoor ambient air temperature.***

- The burner is now ready to be fired. Proceed with the "Temperate Start Procedure"

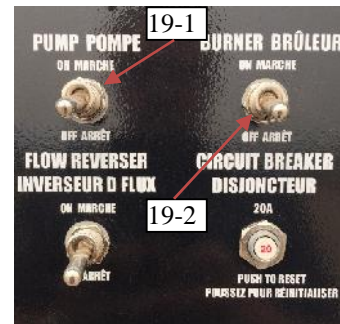

19-GTS 300 control panel

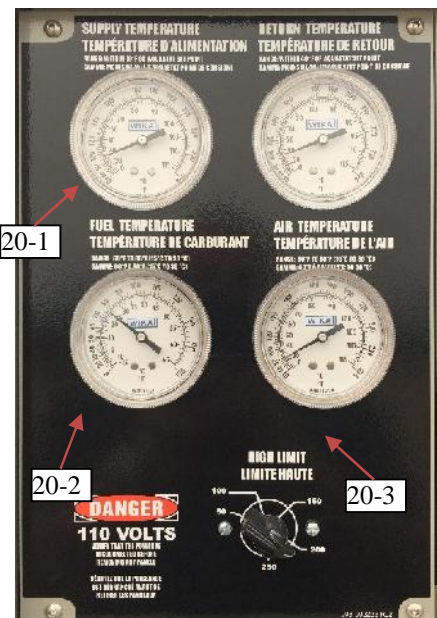

20-temperature gauge panel

# Temperate start procedure

You can proceed with this procedure when;

- The ambient outdoor air temperature is above 50° F (10° C).
- The "cold start procedure" has been completed.

## Control settings

### Low Flow Situations

Utilizing only one Model 80 or Model 200 portable heat exchanger or only one or two circulation line exchanger loops

- Water heater heat exchanger temperature overrun can be expected, therefore, initially set the Aquastat (23-1) at 140°F (60°C).

*Note: A single line heat exchanger loop may not have enough flow to activate the system flow switch. If this occurs, consider adding another loop of hose to increase flow and activate the system.*

### High Flow Situations

Utilizing two or more portable heat exchangers or three or more circulating line heat exchanger loops

- Set the Aquastat (23-1) at 190°F (88°C).

## Initiate firing

- Verify that the "Pump Switch" (21-1) is in the "On" (up) position.
- Toggle the water heater switch (21-2) to the "On" (up) position.
- The burner will proceed through its firing sequence.
- Once the burner is operating smoothly and the system pressure is steady (air has been eliminated from the system), monitor the "supply temperature" (22-1) until it is within 10° F of the Aquastat temperature setting (23-1).
- Verify that only one "heat exchanger loop" or one "portable heat exchanger" is connected to the primary lines through the distribution manifold.
- Monitor the "Return temperature before bypass" gauge (22-2). Before fully connecting more "heat exchanger loops" or "portable heat exchangers", this gauge must show a noticeable rise in temperature indicating the heat transfer fluid has made the full circuit. With "heat exchanger loops, this may take 10 minutes or more.
- Repeat the previous step until all "portable heat exchangers" or "heat exchanger loops" are connected and circulating.

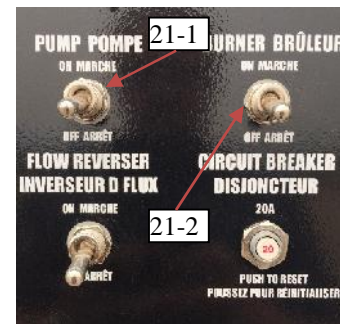

21- GTS 300 control panel

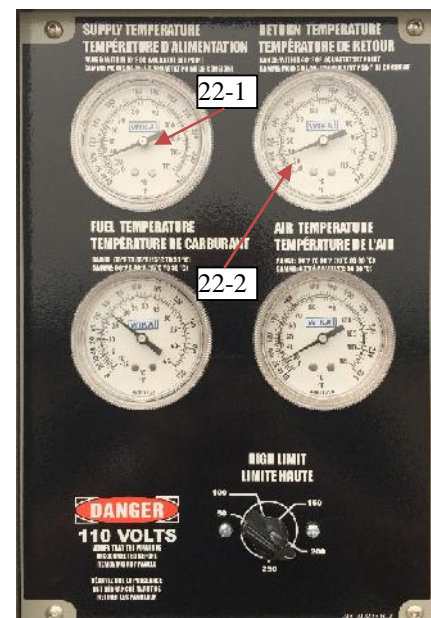

22- Supply and return temperature gauges



23- GTS 300 Aquastat

## Purging air from the fuel system

If the burner does not fire, the fuel system may have to be purged of air.

- Confirm that there is an adequate fuel supply.
- Toggle the water heater switch (24-2) to the "Off" (down) position.
- Ensure that the main fuel valve (25-1) is in the open position. Set valve (26-1) to the "purge" position.
- Confirm that the pump switch (24-1) is in the "On"(up) position.

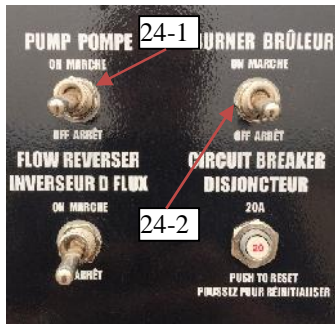

24 – Pump & Water Heater switches

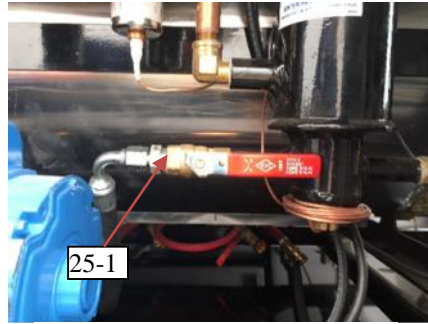

25 – Main Fuel Supply Valve

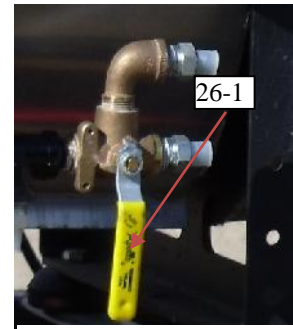

26 - Fuel Purge Valve

- Toggle the water heater switch (24-2) to the "On" (up) position.
- Depress the reset button (27-1). This will activate the fuel pump & burner firing sequence.



27 – Riello burner

- When the fuel system is primed, the fuel pressure gauge (28-1) will show a steady reading and the water heater should attempt to ignite.

*Note: If the water heater does not fire after several attempts see the accompanying "Water Heater Module- Service Manual" or the "Riello Burners Installation Manual" for information and/or contact Technical Support.*

- Once the water heater has ignited and the fuel pressure has stabilized, set the 3-way fuel bypass valve (26-1) to the two-pipe fuel system position (horizontal position).

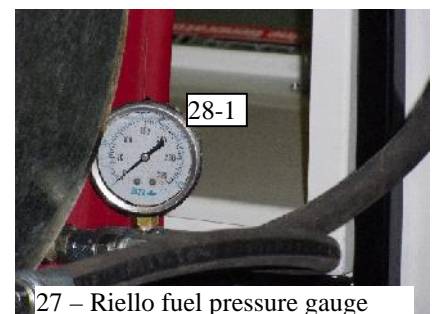

27 – Riello fuel pressure gauge (~ 140psi when operating)

# Adding "HTF" to system

Verify that the power supply is correct and the electrical hook up is as specified in "Setup".

- Ensure all breakers are in the "On" position.
- Attach fill/drain hose extension (29-3) to the Fill/Drain hose (29-1).
- Submerge the fill/drain hose into the bottom of the barrel/pail or jug of pre-mixed "HTF" (See "Setup" for heat transfer fluid specifications).
- Connect the fill/drain hose into the quick coupler located on the intake side of the pump (30-2).
- Turn the pump isolation valve (30-1) to the "Closed" position. (Perpendicular to flow through pipe).
- Turn the fill/drain ball valve (29-2) to the "Open" position.
- Toggle the pump switch to the "On" (up) position.
- Once the pump switch is in the "On" position, the pump will commence to draw the "HTF" into the system. By watching the glycol level gauge (31-1), continue to fill the system until the glycol level gauge shown 1/2 full.

*Caution must be taken when approaching the 1/2 full mark as it could take 2-3seconds to register the actual level once pumping has ceased.*

- In the case of an overfull situation, do the following:
  - Toggle the pump switch to the "Off" (down) position.
  - Verify that the fill/drain ball valve (29-2) is in the "Open" position.
  - Turn the pump isolation valve (30-1) to the "Open" position. Gravity will immediately drain the glycol out of the system through the fill/drain hose. The fill/drain hose should be submerged into a barrel/pail or jug with sufficient room for the "HTF".
  - Once the desired amount of "HTF" has been attained and the glycol level gauge is showing half full, turn the pump isolation valve (30-1) to the "closed" position and continue with the following procedures
- Turn the fill/drain ball valve (29-2) to the "Closed" position.
- Toggle the pump switch to the "Off" (down) position.
- Uncouple the fill/drain hose from the pump.
- Turn the supply ball valve (30-1) back to the "Open" position.

**Refer to Service Bulletin  
SB-1603 located at the back  
of this Manual.**

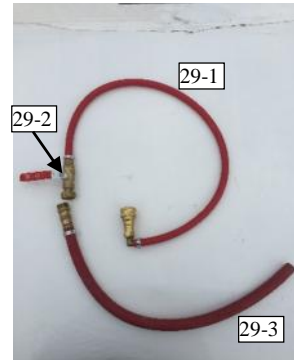

29- fill/drain hose and plug

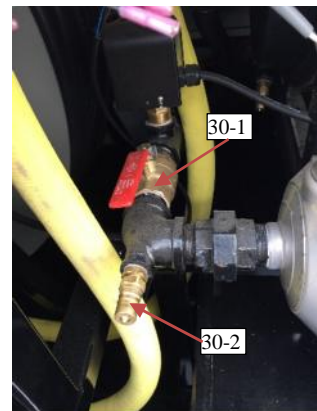

30-Pump isolation valve (open) & Fill/Drain quick coupler



31-Glycol level sight gauge



# Setup/Operation/Maintenance (HR2250)

*Danger! It is very important that you read and understand this section before operating the hose reel! Failure to follow the procedures and cautions in this manual could lead to injury or possible death!*

## Manual Controls

The Hose Reel has a manual method of controlling the spool rotation "UNLOAD/LOAD" and a general ON/OFF power switch.

**Caution!** When NOT operating the reel, put the reel speed toggle switch (32-1) in the "Off" position to prevent accidental activation and possible injury. When the hose reel is to be left unsupervised, the power cord should be unplugged from the power supply.

### Reel Power

Power is present when the power switch (32-1) is in the "ON" position. By connecting the foot switch you can load or unload hose by depressing the foot switch (32-2) which is momentary (will only operate when depressed).

### Reel Direction Modes

Mode 1 - UNLOAD

Mode 2 - LOAD

**Caution!** Do not allow your hands, feet or clothing to become trapped by any of the reel's moving mechanisms.

#### Mode 1 - "UNLOAD"

- The UNLOAD mode is achieved with the mode toggle switch (32-2) in the UNLOAD position.
- The foot switch (33-1) is momentary and will only operate when it is depressed.

#### Mode 2 - "LOAD"

- The LOAD mode is achieved with the mode toggle switch (32-2) in the LOAD position.
- The foot switch (33-1) is momentary and will only operate when it is depressed.
- The hose must be directed manually into position on the hose reel.

*Note: To eliminate initial clutch slippage when loading hose, one loop of hose should be left slack prior to initiating hose loading.*

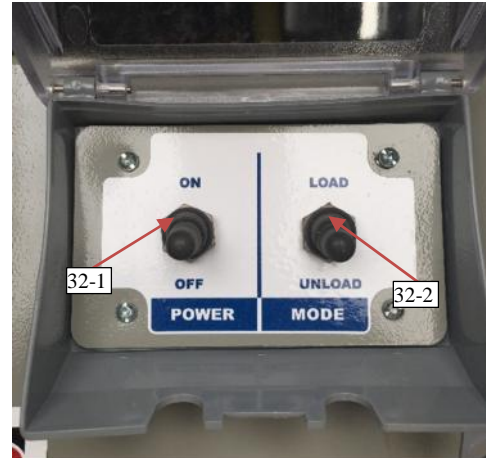

32-Power & mode toggle switches



33 - Foot Switch

# Mechanical Drive Components

## Precautions

Electric shock will result in death or serious injury.

- The user is responsible for conforming to all applicable code requirements with respect to grounding all equipment.
- DO NOT touch unshielded components or screw connections with voltage present.
- Install and close all covers before applying power or starting and stopping the hose reel.
- Before servicing:
  - Disconnect all power.
  - Place a "DO NOT TURN ON" label on the drive controller disconnect.
  - Lock disconnect in the open position.

Access to the internal mechanical drive components is provided through the access door.



34 - Access door

## Manual Resets

If a fault occurs due to a prolonged overload, overvoltage, under voltage or phase failure, the control must be manually restarted. The control can be restarted by:

- 1) Disconnect AC power.
- 2) Check reset button located near the back and on the reel side of the motor.
- 3) Reconnect the AC power.

## Electric Motor

- No regular maintenance is required.
- Low temperature manual reset thermal protector.
- Totally enclosed and fully gasketed construction for dirty environments.
- Make sure that, during operation or storage, the motor is not in prolonged contact with moisture.
- Refer to the chart "Table 1- Electric motor features & data", below for motor data.



35 - Motor & gearbox

PRODUCT FEATURE - ENCLOSED HIGH TORQUE MOTOR			
Model Number:	56C17F5913	Phase:	1
HP:	3/4	Mult. Symb.	F1
RPM:	1725	F.L. Amps	11 /5.4-5. 5
Volts:	115/208-230	Weight Lbs.	30
Frame:	56C	"C" Dim.	12.32
Overload:	MANUAL	Foot Notes:	2
Mounting:	C-FACE	S.F.:	1.15

Table 1 - Electric motor features & data

## Gear box specifications

- HUB CITY - Poweratio 2000, Model HW2042ER (Assy #: 0251-00534)
- Modified helical worm reducer
- 102:1 gear reduction
- 5/8" input shaft size
- 1" output shaft

### CAUTION

Do not operate the unit without ensuring it contains the correct amount of oil. Do not overfill or under fill with oil. Injury to personnel, unit, or other equipment may result.

Oil should be changed with greater frequency if unit is used in severe environment (dusty or high humidity).

### WARNING

Oil, housing, and other components can reach high temperatures during operation, and can cause severe burns. Use extreme care when removing lubrication plugs and vents while servicing the unit.

#### Maintenance & Operation

Oil, housing, and other components can reach high temperatures during operation, and can cause severe burns. Use extreme care when removing lubrication plugs and vents while servicing the unit.

- Do not operate the unit without making sure it contains the correct amount of oil. Do not overfill or under fill with oil, or injury to personnel, unit, or other equipment may result.
- For proper operation in subzero conditions, it is mandatory that the following oil be used: "SWEPCO 212 MOLY MULTI-GRADE GEAR LUBE" any other gear oil will void warranty!

#### Oil Filling Procedure

- Remove Fill (#-1) and Breather Plug (#-2).
- Clean threads on the removed plugs and the plug holes with degreaser.
- Fill gear box with the recommended lubricant (see above) to a level near the center line of the uppermost horizontal shaft or until lubricant comes out of the oil level plug hole.
- Install plugs secure in gear case.

#### Break-In Period

After the first 100 hours of operation, drain out initial oil, flush out the gear case with an approved non-flammable, non-toxic solvent, such as Whitmore's Flushing Oil (#06802030) or Medallion Flushing Oil Kosher (#06812010), and refill. Thereafter, oil should be changed at least every 2500 operating hours or every 6 months - whichever occurs first.

Note: Oil should be changed with greater frequency if unit is used in severe environments (dust or high humidity).

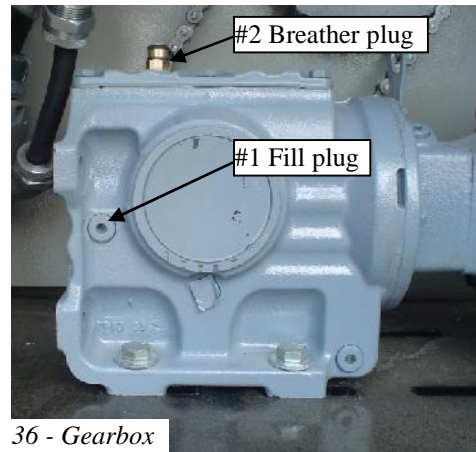

36 - Gearbox

## Torque Limiter Clutch

- The Torque limiter protects the drive line from damage due to overload conditions. The driven center member slips on non-asbestos friction discs during overload situations in the drive line.
- Torque Ratings;  
GLI Model 350 w/ two springs
  - minimum: 60 lb.-ft.
  - maximum: 190 lb.-ft.

Please note that the torque ratings are estimates. Actual torque capacity may vary significantly depending on many factors. Field conditions such as oil, humidity, water and temperature as well as the frequency and duration of slippage all affect torque capacity.

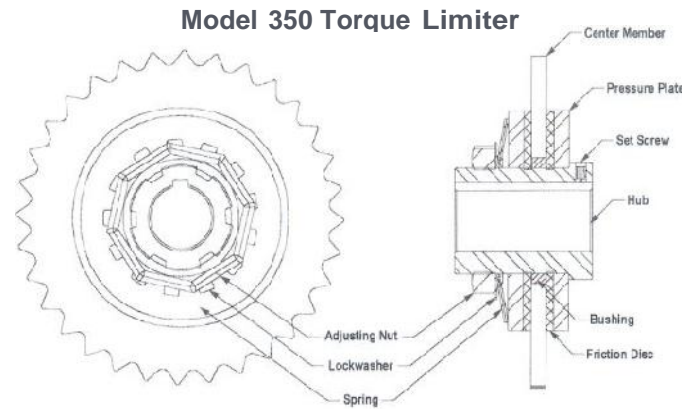

Although the torque limiter clutch is factory set at Dryair, periodic adjustment may be required. It is recommended the torque setting of the clutch be checked twice per season (see "Maintenance" section). With prolonged use, the two friction disks, located on either side of the A-plate sprocket, will eventually show wear.

- It is important that the torque limiter clutch is adjusted properly. If the clutch slips too easily, the spool will take too long to stop and hose will pile up on the reel. If the clutch does not slip at all, damage will occur to the drive system.

**Note: A visual check may be required to confirm whether it is the clutch that is slipping or the motor.**

## Torque Limiter Adjustment

- Although the torque limiter clutch is factory (Dryair) set, periodic adjustment may be required. It is recommended the torque setting of the clutch be checked twice a season. With prolonged use, the two friction disks, located on either side of the A-plate sprocket, will eventually show wear.
- It is important that the torque limiter clutch is adjusted properly. If the clutch slips too easily, the spool will take too long to stop and hose will pile up on the reel.
- Check that the clutch is adjusted properly with the following procedure:

### Physical check

- With no power being applied to the reel, grip the edge of the spool plate and apply full upward force, making sure that you are lifting with your legs and not your back.
- You should be able to cause the clutch to just slip with full lifting force.
- If the clutch does not slip or slips too easily, refer to the "torque adjust procedure", below.

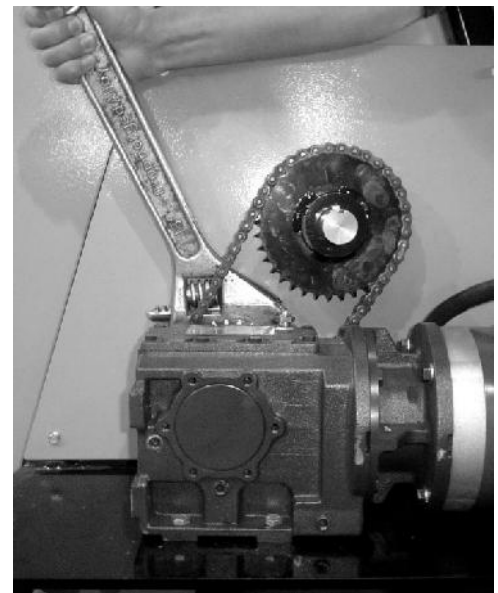

37 - Torque Limiter Adjustment

### **Torque adjust procedure**

- Insure that the adjusting nut is in a finger tight position.
- If the adjustment nut is tighter than finger tight, loosen and complete previous step.
- Using a torque wrench tighten the adjusting nut to 90ft\*lb.

After the break-away torque is set, bend the tabs of the lock washer over *39 - Torque limiter adjuster* the hex flats of the adjusting nut.

Note: The torque limiter clutch nut requires a reasonable amount of force to adjust. Use a torque wrench that provides you with at least 18" of leverage.

### **Run-in procedure**

- If the Torque Limiter has been taken apart and reassembled or friction disks have been changed, it is recommended that the clutch be "run in" by "slipping" the center member (sprocket)
- Insure that the adjusting nut is in a finger tight position.
- Match mark the adjusting nut and hub. Advance the adjusting nut 1/4 tum from finger tight.
- Slip the torque limiter sprocket for 8 minutes at full RPM.
- Refer back to the "Torque adjust procedure" for final readjustment.

# Troubleshooting (CME)

- There are 6 green lights on the control panel, which indicate the status of a sequence of functions while the unit is running.
- Aquastat and burner light go off and on as the burner cycles.
- When the burner is on, all green lights should be on. With the burner on, any light which is not on should be considered burned out.
- Troubleshoot power issues at the control panel terminal control strip. Remove control panel to expose terminal strip.

## No power at outgoing side of water heater toggle switch



Check for 120 volt power between letter N and #1 on the terminal strip. If no power check the following:

- a) Check that the circuit breaker for the water heater has not been switched off.
- b) Check that the toggle switch for the water heater has not been turned off.
- c) Check for power in and out of breaker and toggle switch.
- d) Check that correct power supply has been connected to the unit. Investigate power source and be certain that the power characteristics are correct. (120 volt, 15 amp, single phase, 3-conductor, 0'-100'-12AWG, over 100' - 10AWG)

## No power at Terminal#4 on low water cutoff



Check for 120 volt power between letter N and #2 on the terminal strip. If no power check the following:

- a) Low water situation. Check fluid level in tank and add if necessary.

## No power at flow switch

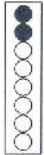

Check for 120 volt power between letter N and #3 on the terminal strip. If no power check the following:

- a) Pump not running. - Check pump breaker and toggle switch on control panel. - Check for 120 volts at pump motor. If correct power is confirmed at motor, but pump won't run, refer to "G&L Pumps, Installation, Operation & Maintenance Instructions, 11- Troubleshooting Chart" for more in-depth troubleshooting.
- b) Inadequate flow.
  - Check that all valves are open in the fluid-transfer loop. - Filter screen may be plugged. Use flush hose/valve attachment into a bucket, while pump is running, for a quick Y-strainer flush (see Y-strainer flush in Maintenance section of Operators Manual). Eventually the system may have to be drained and the filter screen removed and cleaned by hand (see Y-strainer screen in Maintenance section of Operators Manual). - Check that pressure bypass valve is open, if fluid-receiving units are closed off.
  - When performing "ground thaw" or "concrete cure" application, the use of only one "heat exchanger loop" may result in inadequate flow. Utilizing at least two "heat exchange loops" will provide adequate flow or a short bypass loop can also be incorporated to correct this situation.
  - Air present in the circulation system. Air in the system can cause cavitation in the pump and pressure loss. Refer to "Operation, Purging air from the system" for air purging instructions.
  - Supply temperature overrun causing vaporization (steam) & pump pressure to be lost. Cavitation will occur in the "water heater heat exchanger" causing a noticeable bubbling, popping sound. Check the "overflow outlet" to confirm presence of fluid vapor. If vaporization is occurring, the "Aquastat" setting is set too high. Reset the "Aquastat" to a lower temperature (10°F increments) and allow cool-down. When the "heat transfer fluid" cools down, the system will regain pump pressure. Allow the burner to cycle back on and observe to ensure that the vaporization situation does not reoccur. If it does reoccur, reset the "Aquastat" to a lower temperature until the problem is rectified.

*Note: This situation will occur more often in a "low flow" situation (refer to Operation, Temperate Start Procedure, Control Settings).*

- c) Defective flow switch. - If a) and b) check out good, the flow switch will need to be re-calibrated, or replaced.

### No power at Aquastat



Check for 120 volt power between letter N and #6 on terminal strip. If no power check the following:

- Check setting on Aquastat.
- Check sensor and verify that it is intact in its well.
- If a) and b) check out good, replace both Aquastat and sensor.

### No power at outgoing side of high limit switches



Check for 120 volt power between letter N and #5 on the terminal strip. If no power check the following:

- Manual reset high limit reset button tripped.
- Check settings of switches. The automatic high limit should be set 10°F higher than the set point of the Aquastat, and the manual reset high limit should be set 10°F higher than the automatic high limit switch.
- Determine which high limit switch is defective and replace.

### No power at burner



Check for 120 volt power between letter N and #7 on the terminal strip. If power check the following:

- Check for 120 volt power at the burner. If power present there is a fault in the burner. See the enclosed Riello burner information to trouble shoot the burner system.

**TROUBLESHOOTING**

**INDICATOR LIGHTS**

- \* There are 6 green lights on the control panel, which indicate the status of a sequence of functions while the unit is running.
- \* When burner is on, all green lights should be on as well. Any light, which is not on should be considered burned out.
- \* Aquastat and burner light go off and on as the burner cycles.
- \* The terminal strip, located behind the control panel, must be accessed to initiate troubleshooting procedures.

**No power at out-going side of water heater toggle switch**  
Check for 120 volt power between letter N and #1 on the terminal strip. If there is no power, check the following:

- Check that the pr circuit breaker has not been switched off.
- Check that the water heater toggle switch has not been turned off.
- Check for power in and out of breaker and toggle switch.
- Check that correct power supply has been connected to the unit. Investigate power source and be certain that the power characteristics are correct. (115 volt, 15 amp, single phase, 3-conductor, 0-100° - 12 AWG, over 100° - 10 AWG.)

**No power at terminal #4 on low water cut-off**  
Check for 120 volt power between letter N and #2 on the terminal strip. If there is no power, check the following:

- Low water situation. Check fluid level in tank and add if necessary.
- Check fuse in low water cut off. Replace if required.

**No power at flow switch**  
Check for 120 volt power between letter N and #3 on the terminal strip. If there is no power, check the following:

- Pump not running. - Check pump breaker and toggle switch on control panel. - Check for volts at pump motor. If correct power is confirmed at motor, but pump won't run, replace pump.
- Inadequate flow. - Check that all valves are open in the fluid-transfer loop. - Filter screen may be plugged. Use flush hose/valve attachment into a bucket, while pump is running, for a quick flush. Eventually the system may have to be drained and the filter screen removed and cleaned by hand. - If fluid-moving units are closed off, check that the pressure by-pass valve is open.
- Defective flow switch. - If a) and b) check out, the flow switch will need to be re-calibrated or replaced.

**No power at out-going side of high limit switches.**  
Check for 120 volt power between letter N and #5 on the terminal strip. If there is no power, check the following:

- Manual reset high limit - Check and reset if it has tripped.
- Check switch settings. The auto-matic high limit should be set 10°F higher than the set point of the aqua-stat, and the manual reset high limit should be set 10°F higher than the auto-matic high limit switch.
- Determine which high limit switch is defective and replace.

**No power at aqua-stat**  
Check for 120 volt power between letter N and #6 on terminal strip. If there is no power, check the following:

- Check that setting on aqua-stat is at desired operating temperature.
- Check well sensor (electronic), and verify that it is intact and positioned properly in its well.
- If a) and b) check out, replace both aqua-stat and well sensor.

**No power at burner**  
Check for 120 volt power between letter N and #7 on the terminal strip. If there is power, check the following:

- Check for 120 volt power at the burner. If power is present, there is a fault in the burner. See manual to trouble shoot burner system.

**FOR ADDITIONAL ASSISTANCE, CALL 1(888) 750 1700**  
003-90 2232

**DÉPANNAGE**

**TÉMOIN S'ALLUME**

\* Il y a 6 lumières verts sur le panneau de commande, qui indiquent état d'une séquence de fonctions lancés que l'appareil fonctionne.

\* Lorsque le brûleur est allumé, tous les lumières verts doivent être allumés aussi. Toute la lumière qui ne s'est pas allumée, doit être considéré brûlée.

\* La lumière d'aquastat et de brûleur s'arrête et s'allume alors que le brûleur cycle.

\* La barrette de raccordement, situé derrière le panneau de commande, doit être évalué pour initier les procédures de dépannage.

**Aucune alimentation à côté sortant d'interrupteur à bascule de chauffe-eau**  
Vérifiez s'il y a 120 volts de puissance entre le lettre N et #1 sur la barrette de raccordement. S'il n'y a pas de puissance, vérifiez les points suivants:

- Vérifiez que le disjoncteur pr n'a pas été éteint.
- Vérifiez que interrupteur à bascule de chauffe-eau n'a pas été éteint.
- Vérifiez la puissance en et hors de disjoncteur et d'interrupteur à bascule.
- Vérifiez que l'alimentation électrique correcte a été connecté à l'appareil. Enquêter la source d'alimentation et soyez certain que les caractéristiques de puissance sont correctes. (115 volt, 15 amp, monophasé, 3-conducteur, 0°-100° - 12 AWG, plus de 100 - 10 AWG)

**Aucune alimentation à terminal #4 sur interrupteur à bas niveau d'eau**  
Vérifiez s'il y a 120 volt de puissance entre le lettre N et #2 sur la barrette de raccordement. S'il n'y a pas de puissance, vérifiez les points suivants:

- Situation de bas niveau d'eau. Vérifiez niveau de carburant dans le réservoir et ajoutez au besoin. b) Vérifiez le fusible de interrupteur à bas niveau d'eau. Remplacez au besoin.

**Aucune alimentation au commutateur de flux**  
Vérifiez s'il y a 120 volt de puissance entre le lettre N et #3 sur la barrette de raccordement. S'il n'y a pas de puissance, vérifiez les points suivants:

- Pompe ne fonctionne pas. - Vérifiez le disjoncteur de pompe et l'interrupteur à bascule sur le panneau de commande. - Vérifiez s'il y a volts à moteur de la pompe. Si la puissance correcte est confirmé à moteur, mais la pompe ne fonctionne pas, remplacez la pompe.
- Flux inadéquate. - Vérifiez que toutes les vannes sont ouvertes dans la boucle de transfert de fluide. Écran de filtrage peut être branché. Utilisez la fixation du tuyau/de la vanne de flush dans un seau, lorsque la pompe fonctionne, pour un flush rapid. Finalement la système peut avoir d'être drainé et l'écran de filtrage enlevé et nettoyé à la main. - Si les unités de récupération de fluide sont collées, vérifiez que la vanne de pression de couramment est ouverte.
- Commutateur de flux défectueux. - Si a) et b) retiré, le commutateur de flux devrait être recalibré ou remplacé.

**Aucune alimentation à côté sortant de commutateurs de limite haute.**  
Vérifiez s'il y a 120 volt de puissance entre le lettre N et #5 sur la barrette de raccordement. S'il n'y a pas de puissance, vérifiez les points suivants:

- Limite haute réinitialisation manuelle. Contrôlez et réinitialisez s'il s'est déclenché
- Contrôlez paramètres de commutation. La limite haute automatique doit être 10 F plus élevée que le point de consigne de l'aquastat, et la limite haute réinitialisation manuelle doit être 10 F plus élevée que le commutateur de limite haute automatique.
- Déterminez quel commutateur de limite haute est défectueux est remplacé.

**Aucune alimentation à l'aquastat**  
Vérifiez s'il y a 120 volt de puissance entre le lettre N et #6 sur la barrette de raccordement. S'il n'y a pas de puissance, vérifiez les points suivants:

- Vérifiez que le paramètre à l'aquastat est à la température de fonctionnement souhaitée. b) Vérifiez le capteur de puits (électronique), et contrôlez qu'il est intact et correctement positionné dans son puits. c) Si a) et b) retiré, remplacez aquastat et capteur de puits.

**Aucune alimentation à le brûleur**  
Vérifiez s'il y a 120 volt de puissance entre le lettre N et #7 sur la barrette de raccordement. S'il n'y a pas de puissance, vérifiez le point suivant:

- Vérifiez s'il y a 120 volt de puissance à le brûleur. Si l'alimentation est présente il y a un défaut dans le brûleur. Voir le manuel pour dépannage de le système de brûleur.

**POUR UNE ASSISTANCE SUPPLÉMENTAIRE, APPELÉZ 1(888) 750 1700**  
003-902232R01

# Maintenance

## Central Heating Module

### Daily checklist

A daily inspection of the water heater cabinet should be performed with attention paid to the following:

#### Check for strong odor of fuel

- If a leak or the odor of fuel is noticed, immediately turn off all power switches and the main fuel supply to the water heater cabinet.
- Ventilate the water heater cabinet.
- Find and correct the leak before turning on any power or trying to relight the water heater.

#### Check heat transfer fluid "HTF" level every day

- Maintain between 1/4 and 3/4 on the heat transfer level gauge when fluid is hot
- Top up as necessary
- For "HTF" specifications, see "Setup, Heat Transfer Fluid "HTF", Fluid Specifications.
- For "HTF" handling precautions, refer to the "Safety Concerns, Material Safety Data Sheet".
- If loss of fluid is excessive, check for leaks at all fittings and connections in the water heater cabinet as well as the fluid circulation system.

#### Check the supply temperature gauge

- Verify that the supply temperature gauge is within 10°F of the Aquastat setting.

### Seasonal checklist

#### Fuel (water block / particulate) filter

- The water block/particulate filter should be changed every heating season or as required.

#### Hoses

- Periodically check all hoses for damage due to aging, elevated temperatures, over-torqued hose clamps, abrasion and weathering.
- Replace damaged hoses as required.
- Seasonally check hose clamp torque and adjust accordingly.

#### Water heater heat exchanger

- Keep the flues in the water heater clean. Because soot is a nonconductor of heat, a dirty water heater requires more oil to heat a structure than a clean one. Water heaters can corrode on the fireside. This results from corrosive substances in the fuel and can be difficult to control. Some fuel oils contain substances, which cause fireside corrosion. Sulphur, vanadium and sodium are among the materials that may contribute to this problem. The probability of trouble from this source depends to a large degree on the amount of Sulphur in the fuel and on the care used in cleaning the fireside heating surfaces. This is particularly true when preparing a boiler for a period of idleness. Preventing this problem also depends on keeping the boiler heating surfaces dry when a boiler is out of service.
- The person responsible for water heater maintenance should be certain that the fireside surfaces of the water heaters in his care are thoroughly cleaned at the end of the firing season. He should also observe the fireside surfaces during the firing season and if signs of corrosion are discovered, a reputable consultant should be contacted.
- The flue pipe and chimney cap should be taken off once a year and thoroughly cleaned of all soot.



### Heat exchanger cleaning procedure

- Remove the burner from the water heater.
- Vacuum all debris.

### Heat transfer fluid "HTF"

- A clean, properly maintained hot water system should not be drained unless: there is possibility of freezing, the boiler has accumulated a considerable amount of sludge or dirt on the water side, or draining is necessary to permit repairs. Very little sludge should accumulate in a water heater where little make-up water is added and where an appropriate water heater water treatment is maintained at proper strength.
- The Heat transfer fluid should be tested from year to year for freeze protection and should be strong enough for your area. The heat transfer fluid should be checked with a refractometer. Check the glycol/water mixture chart (see "Setup, Heat transfer fluid HTF) for mixing ratios.
- The "pH level" of the heat transfer fluid requires an annual check to see if the pH level is neutral. The pH level should be at 7. This should be checked with a pH instrument.

See "Setup, Heat transfer fluid HTF, Heat transfer fluid specifications" for complete heat transfer fluid specifications

### Burner

- For burner seasonal maintenance, see the "Service Manual".

### "Y" strainer

#### "Y" strainer flush

- The "Y" strainer (38-1) requires regular maintenance every time system is set up or 1000 hours of operation.
  - Remove the end plug from the end of the strainer outlet valve
  - Position a 5-gallon container at the outlet valve.
  - With the pump running, crack the strainer valve a number of times. A quick on/off action of the valve will provide the short bursts required to backwash and clean the strainer. The removal of a couple of gallons of heat transfer fluid should be adequate.

*NOTE: Be certain not to run the reservoir empty, as this would allow air to enter the system.*

- The extracted heat transfer fluid can be reused. Before pouring the fluid back into the reservoir, the fluid must be filtered to remove impurities. Filtering the fluid through a cotton cloth or paper is adequate.



38 - Back washing Y-strainer

### "Y" strainer screen cleaning procedure

- Clean the screen (39-1) located inside the "Y" strainer prior to every installation.
  - Remove the end plug from the end of the strainer outlet valve
  - Position a container at the outlet valve. A couple of 5 gallon containers should do.
  - With the pump "off", drain off the "HTF" until there is no more flow.
  - Remove the top of the "Y" strainer and extract the screen (39-1)
  - The screen should be cleaned using warm water and a soft bristled brush.
  - Reassemble and ensure that all fittings are tight
  - The extracted heat transfer fluid can be reused.
  - Air will have to be purged from the system. Refer to "Operation, Purging air from the "HTF" circulation system" for instructions.

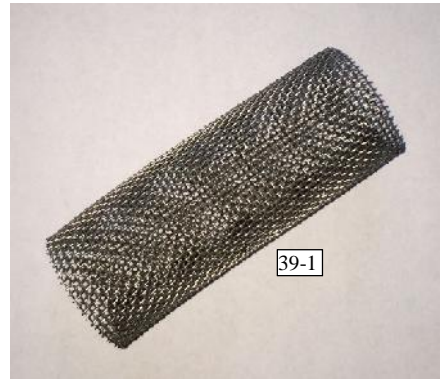

39 - Y-Strainer Screen

# Addendum

## Important Certification & Operational Information Decals

### Non-pressure vessel decal

<b>ATTENTION!</b>	
<p>This Unit is Certified to CSA &amp; UL Standards for use as a <b>NON-PRESSURE VESSEL</b></p> <ul style="list-style-type: none"><li>-The unit includes an <b>open atmospherically vented</b> expansion tank.</li><li>-The expansion tank is integrally connected to the heat-exchange section of the water heater by means of a permanently open line (no valves).</li><li>-The heat exchange section connects to the inlet side of the circulating pump and therefore, only neutral atmospheric pressure is present within the heat exchange section.</li></ul>	<p>Cet appareil est certifié aux normes de CSA et UL pour l'utilisation comme un <b>NAVIRE SANS PRESSION</b></p> <ul style="list-style-type: none"><li>- L'appareil inclut un ouverte réservoir d'expansion atmosphérique ventilé.</li><li>- Le réservoir d'expansion est relié intégralement à la section d'échange de chaleur du chauffe-eau au moyen d'une ligne ouvert en permanence (pas de vannes).</li><li>- La section d'échange de chaleur se connecte à le côté d'entrée de la pompe de circulation et donc, seulement la pression atmosphérique neutre est présent à l'intérieur de la section d'échange de chaleur.</li></ul> <p>003-900454R01</p>

40 - Non-pressure Vessel decal

# Certification & Heater Specifications



P.O Box 126  
400 Service Road  
St. Brieux, SK  
Canada  
S0K 3V0



MADE IN CANADA

<b>DRYAIR Model:</b>	300 GTS	<b>Reference:</b>	
<b>Serial No.:</b>		<b>Prod. Sched.:</b>	

Main Power	
Volts:	120 V
Phase:	1
Hz:	60 HZ
Max. Ampacity	20 A
Control Voltage	24VAC

Oil Burner		
Model:	Riello 40-F10	
Fuel:	#2 Heating Oil	#1 Heating Oil
Calorific Value:	140,000 BTU / US Gal.	136,000 BTU / US Gal.
Output:	223,000 BTUH	217,000 BTUH
Fuel Input:	1.75 US GPH	
Pump Pressure:	145 P.S.I.	

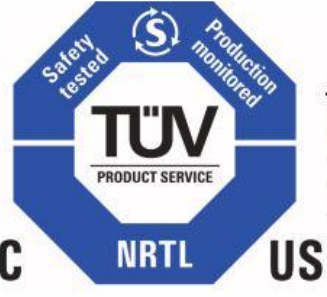

**C** **NRTL** **US**

**COMPLIES TO:**  
 UL 508A/CAN CSA C22.2 No.14  
 UL 726/CAN CSA C22.2 No.3  
 CAN/CSA C22.2 No. B140.7.2  
 CAN/CSA C22.2 No.B139  
 ANSI/NFPA 31

Clearances:	
Sides	24" (61cm)minimum
Flue	36" (91cm)minimum
Floor	0" (0cm) non-combustible

003-902772

41 - Water Heater Data & Serial Plate

# Electrical schematics

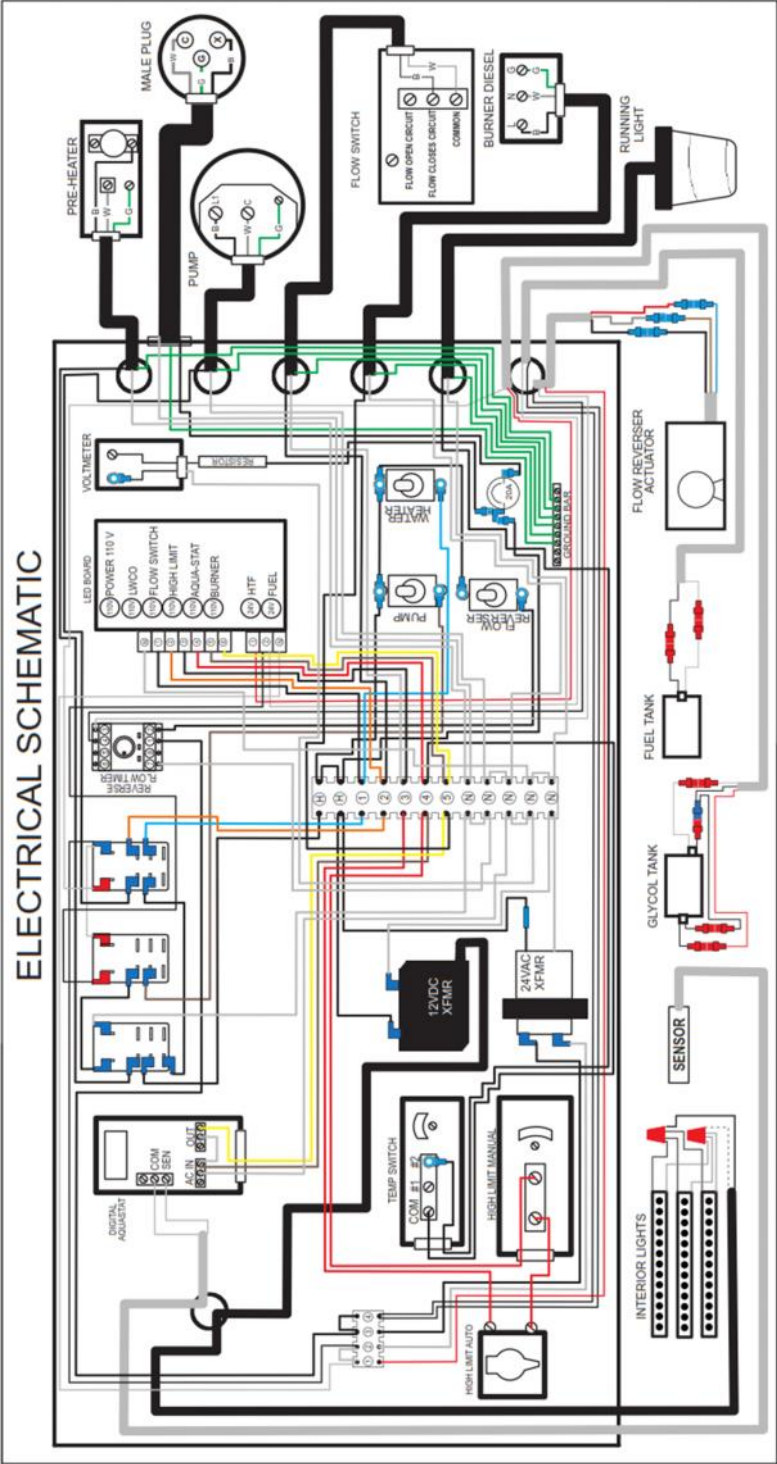

42- Water Heater electrical schematic

# Hose Reel Electrical schematics

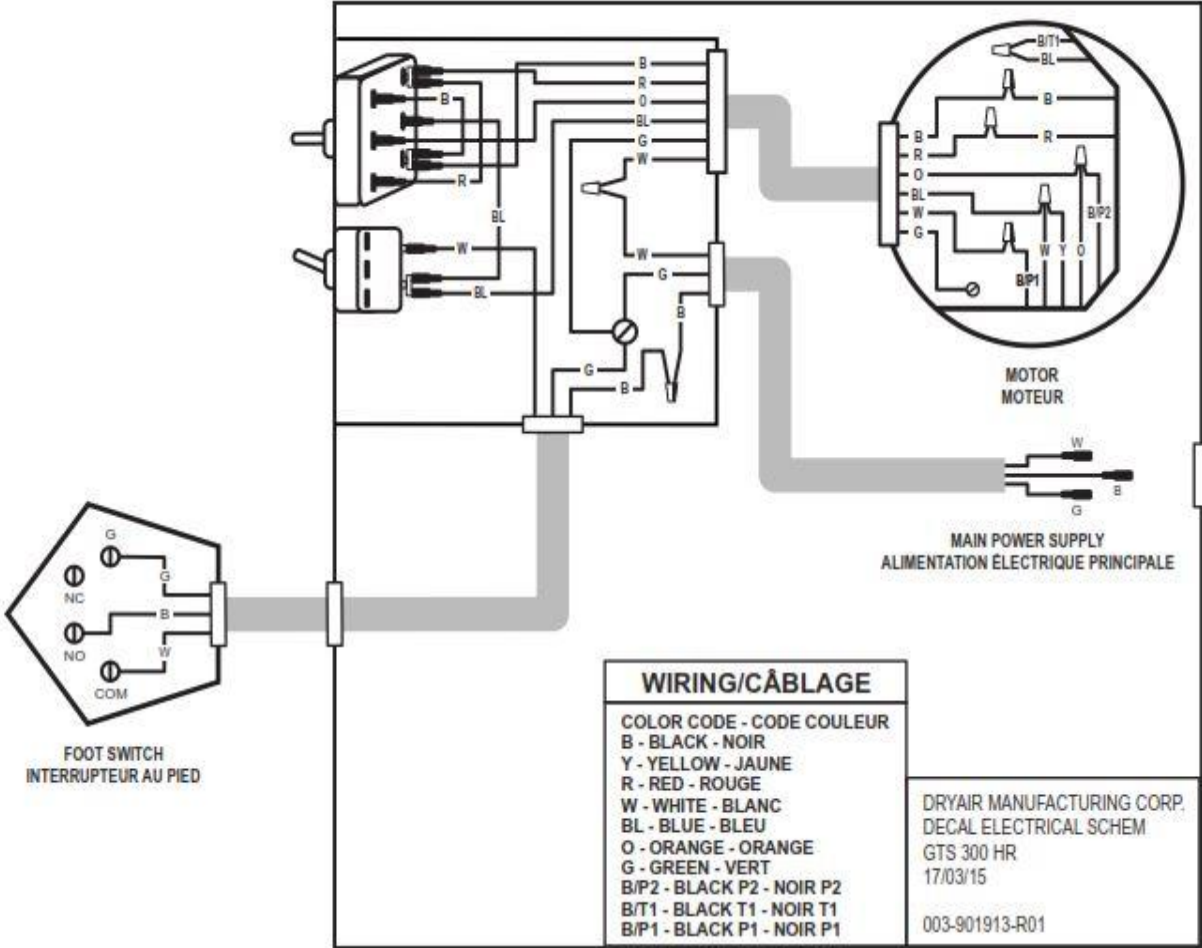

43 - HR2250 electrical schematic

# GTS 300 Trailer Wiring Schematics

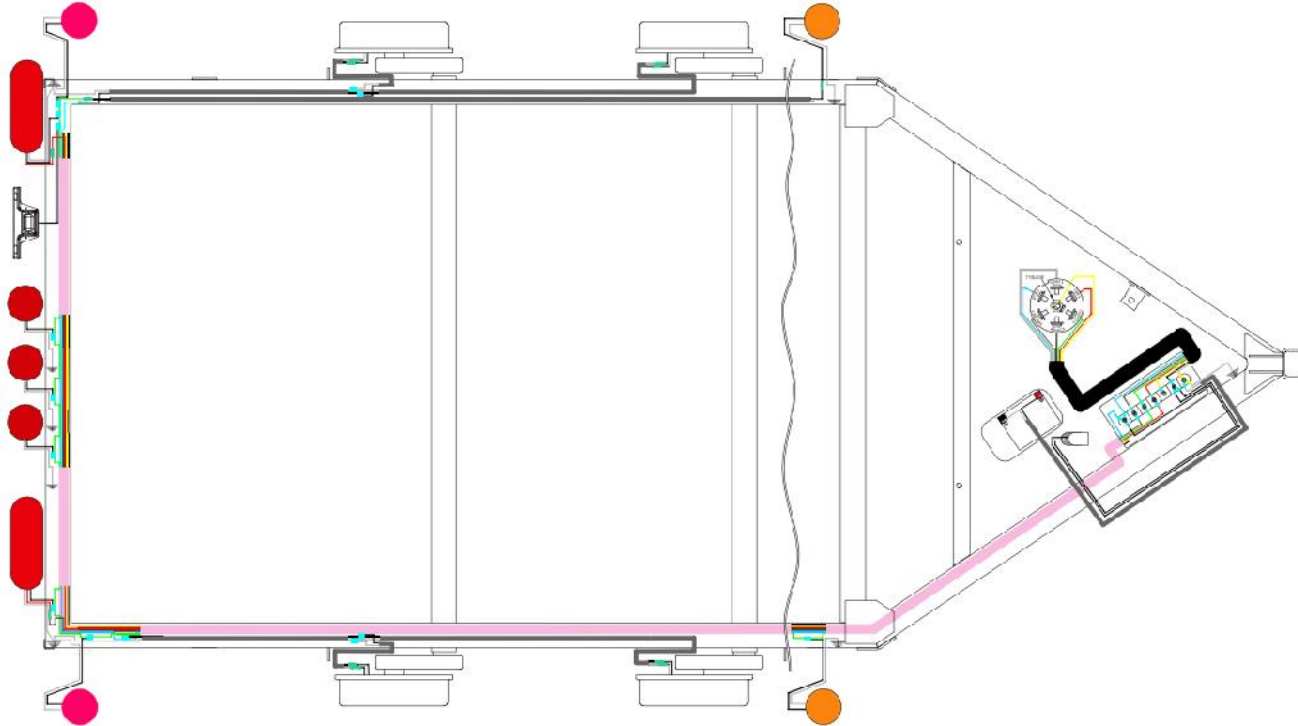

Main Trailer Cable = EPM 14/6 (shown in pink)

- Black Not Used
- Yellow Not Used
- Red Left Signal
- Brown Right Signal
- Blue Brakes
- Green Running Lights

Miscellaneous Cable = EPM 14/2 (Shown in grey)

- Black Running Lights  
Brakes  
Battery Charge
- White Ground

Emergency Brake Battery  
Emergency Brake-Away Switch

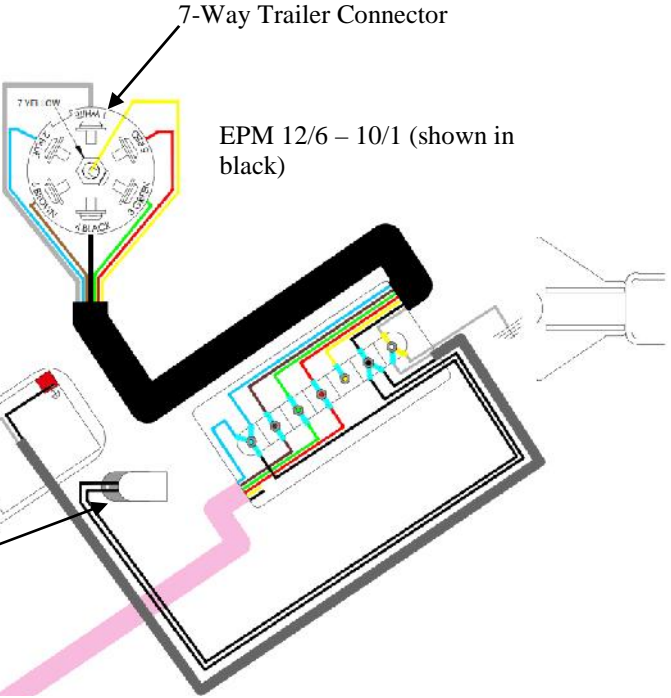

44 – GTS300 Trailer electrical schematic

# Service Bulletin

To: All Dryair Customers  
 From: Dryair Service Dept.  
 Date: January 19, 2016  
 Bulletin #: SB 1601  
 Re: Adding a service loop to (assist with flow issues in scenario's where only using a single loop of hose is required).  
 Models Affected: All GTS300's

It has come to light that the current set up with the GTS 300's when operating with minimal ground thaw loops the flow switch adjustment cannot be set low enough for minimal loop scenarios and will not allow the unit to run. . This is due to a part change from our supplier that we were unaware of. The flow switch that Dryair historically used, FS10C, is no longer available and that FS-200-W was a direct replacement. To address this a small amount of bypass fluid flow is needed to insure proper function in minimal loop scenarios.

**NOTE: BYPASSING THE FLOW SWITCH COULD CAUSE CATASTROPIC FAILURE AND SHOULD NEVER BE DONE.**

Dryair is issuing this bulletin and providing a service kit to address this issue.

This kit contains the following;

- 011-903224 – Elbow Street 90deg 3/8 Brass
- 018-903228 – By-pass hose
  - 011-903223 – Nipple 3/8 closed Black
  - 011-903225 – Coupler reducing 3/4" – 3/8" Black
  - 011-702062 – Nipple combination (hose barb) 3/4" Black
  - 011-900429 – Quick coupler 3/8" Female
  - 001-700062 – Clamp #20 gear
  - 013-702642 – 28" Hose 3/4" Red Horizon 750°F

Installation instructions;

If the By-pass hose 018-903228 will fit onto the male quick connect on the "Y" strainer make that connection and attach the second end of 018-903228 to the male quick connector located at the bottom of the heat exchanger.

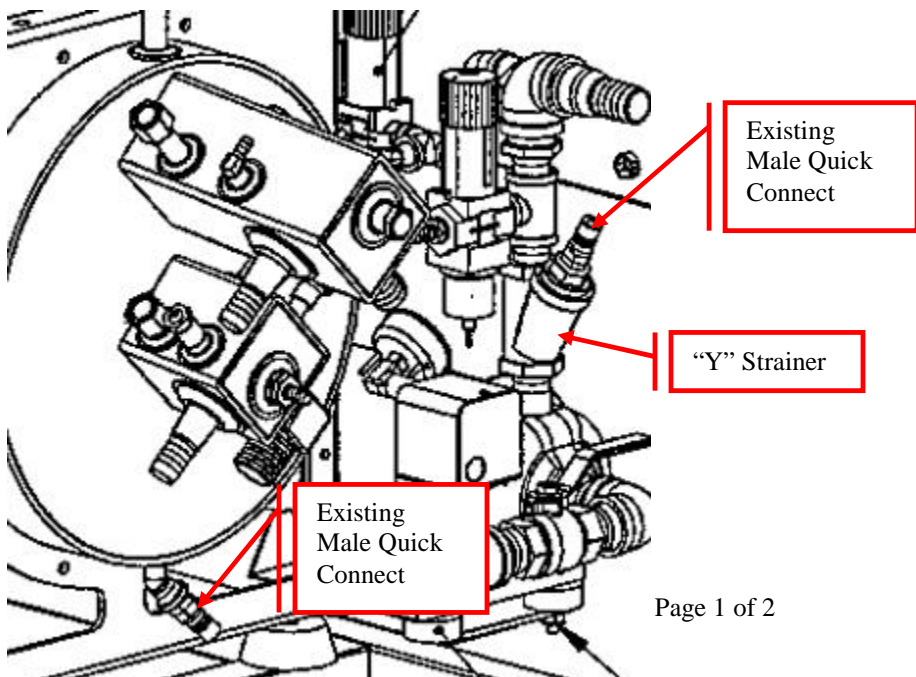



There is a possibility that the supplied By-pass hose 018-903228 with female quick connects will not fit easily onto the “Y” strainer’s male quick connect. To make sure that we cover all cases an extra street elbow has been supplied. The instructions below cover that scenario.

1. Shut off all power to the machine.
  2. Pinch off the 3/8” red Glycol hose above the “Y” strainer.
  3. Slowly remove the Quick connector from the top of the second branch of the “Y” Strainer (\*Caution\* there will be a small amount of glycol loss at this stage).
  4. Clean threads from the “Y” Strainer and install the street elbow 011-903224 into the “Y” Strainer as shown.
  5. Reinstall the quick connector that was removed in step 2 to the end of the elbow 011-903224.
  6. Attach one end of 018-903228 to the quick connector on the “Y” strainer.
  7. Attach the second end of 018-903228 to the male quick connector located at the bottom of the heat exchanger.
- 

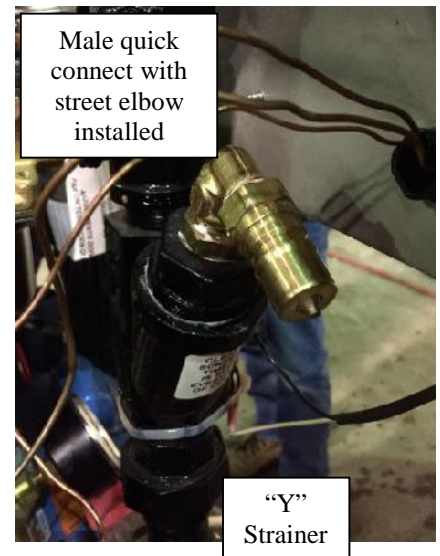

# Service Bulletin

**To:** All Dryair Customers  
**From:** Dryair Service Dept.  
**Date:** January 25, 2016  
**Bulletin #:** SB 1602  
**Re:** Informational on locking the Aquastat at a given temperature.  
**Models Affected:** All GTS 300's

The purpose of this bulletin is to show how locking the Aquastat is possible to protect the owner from an end-user adjusting Aquastat higher than 180F which could cause some problems in certain cases.

If lower temperature is desired by an end user, it can be achieved by using the Automatic High Limit (shown below).

The Aquastat is the digital thermostat located in the center panel on the GTS300, and will display the current temperature of the HTF (Heat Transfer Fluid) at the sensor location.

Approximate time to complete change is 15 Minutes.

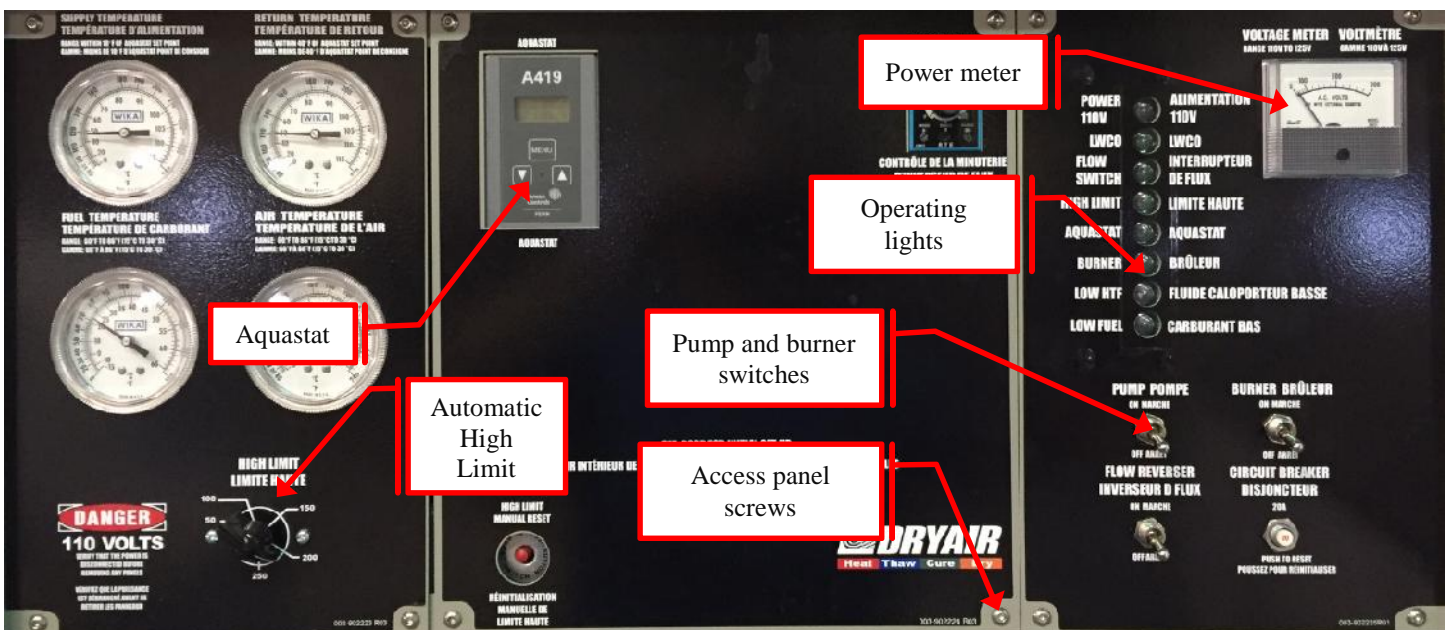

To lock the Aquastat;

1. Set the Aquastat to the maximum level desired (Factory setting is 170°F).
  - a. Ensure power to the machine (Power meter should read 110v).
  - b. Turn the pump and the burner switches on.
  - c. The top six lights will come on.
  - d. Press Menu on the Aquastat (SP should be on the display).
  - e. Press Menu again (the set point temperature should be on the display).
  - f. Adjust using the up/down arrows accordingly.
  - g. Press Menu again to complete the adjustment.
  - h. Turn the burner and pump switch off.
2. Disconnect power from the machine.
3. Remove the four access panel screws and remove the panel.
4. Remove the two screws at the bottom of the Aquastat to access the jumpers.



Lock out jumper



Remove these screws

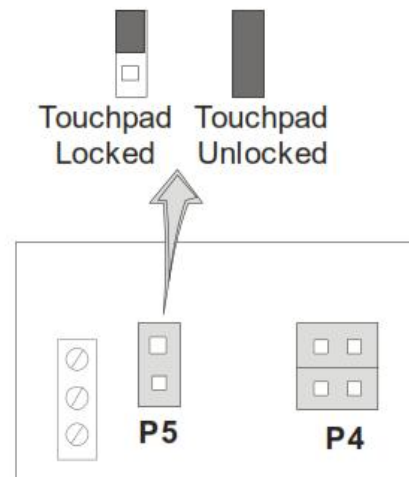

5. To lock it out, move the jumper to either pin and leave the second pin bare.
6. Reinstall the cover and center panel.
7. Apply power to the machine.
8. Turn on the pump and burner switch.
9. Monitor the temperatures to ensure the burner will shut off at the set point.
10. Attempt to adjust the set point using steps “d” & “e” from step “1”.



For any technical assistance and / or support please call;  
Canada Toll Free 1-888-750-1700  
Local (306)275-4848

---

# Service Bulletin

**To:** All Dryair Customers  
**From:** Dryair Service Dept.  
**Date:** February 1, 2016  
**Bulletin #:** SB 1603  
**Re:** HTF Fill Pump  
**Models Affected:** All GTS300's

---

## P/N 018-903245 Optional HTF FILL PUMP – GTS300

### Purpose:

To cover the addition of an Enhancement to the Equipment;

1. To Simplify the addition of glycol in all circumstances.
2. Installation of this device will make it possible to add glycol without shutting the machine down.

For instruction on installation see document # 160201-01 attached to this service bulletin.

### Terms:

Dryair will provide, at No Charge, the HTF FILL PUMP, complete with all the necessary hardware. This will include freight (by ground transportation).

Dryair will cover labor of up to One Hour to install. Travel is NOT covered.

When installation is complete, please fill out the attached warranty claim report to receive credit.

### Ordering Information:

Part Number 018-903245

Canada

Parts dept.

Toll free (888)-750-1700

Local (306)-275-4848 ext. 2406

Fax (306)-275-4664

For any technical assistance and / or support please call;  
Canada Toll Free 1-888-750-1700  
Local (306)275-4848

## HTF FILL PUMP

### 018-903245 PKG FILL PUMP SHURFLO RETROFIT



## RETROFIT INSTALLATION



The HTF FILL PUMP retrofit kit is designed to improve ease of filling HTF (Heat Transfer Fluid) into the GTS 300. This package will allow you to add HTF to a system with an auxiliary pump.

The procedure with the Kit installed is: OPEN the ½" BALL VALVE (on the FILL HOSE) near the main pump (under the control panel); INSERT the SUCTION HOSE into your replacement HTF source; and turn ON the pump. When finished filling, CLOSE the ½" BALL VALVE on the FILL HOSE to prevent loss of fluid.

**Note: During the installation process you can expect to lose roughly 1 gallon of HTF, which can be recovered for later re-use in your unit. Alternately the system can be completely drained.**

**Note: This process will take approximately ½ hour.**

To install the retrofit kit:

- 1) Attach the bracket as shown in *Fig 1.1* using the included square u-bolts (*Part #15* on the parts breakdown diagram on the next page). The back of the bracket should be 8" ahead of the front support strap for the glycol pre-heater. This is located inside the Driver's side Door of the machine.

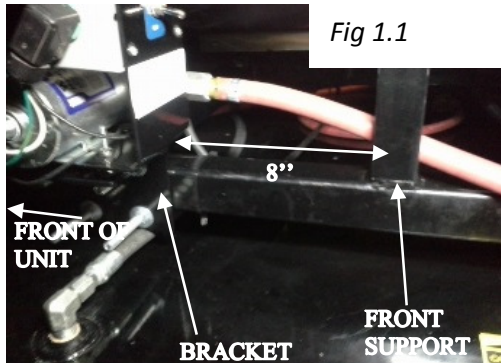

String the FILL HOSE and the POWER CORD along the top of the diesel fuel tank across the unit –under the heat exchanger - towards the control panel.

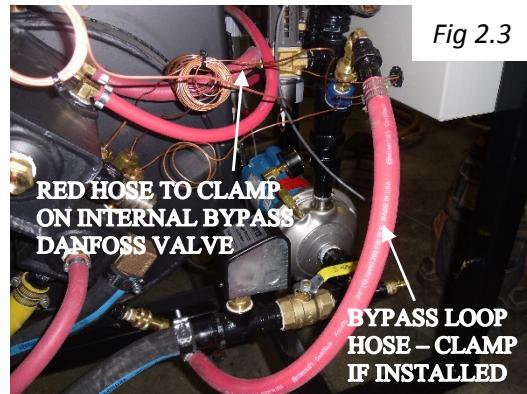
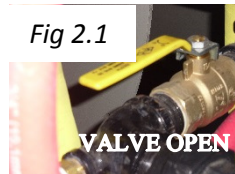

- 2) CLOSE the isolation valve that is located on the input side of the main pump. (Shown in *Fig 2.1* and *Fig 2.2*).

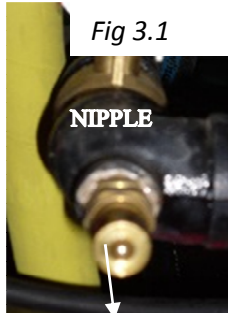

Fig 3.1

Clamp the RED 1/2" hose that exits the plumbing assembly - on the internal bypass Danfoss valve - above the control panel, as in Fig 2.3. If your unit has received the Bypass loop upgrade hose, it must also be clamped as shown in Fig 2.3.

3) Spin out the quick-disconnect NIPPLE currently on the machine, by the bottom of the main pump (under control panel). See Fig 3.1.

Install the STREET ELBOW (Part #27 in the attached diagram) included in the retrofit kit in the port you just opened. Install the quick-disconnect NIPPLE into this STREET ELBOW, and tighten until the NIPPLE faces at a DOWNWARD and SIDEWAYS angle.

Remember to use thread sealant. 1/2" PTFE (Teflon) tape is sufficient for brass-brass sealing.



Fig 3.2

4) Release the clamp on the 1/2" RED hose, the service loop hose (if equipped), and open the isolation valve. Refer to Fig 2.1 and Fig 2.3.

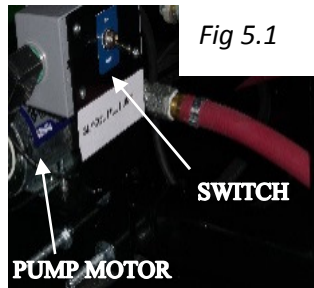

Fig 5.1

5) Plug in the HTF FILL PUMP and then switch the power ON. Verify that the pump is running by listening for sound from the pump's motor. This is shown in Fig 5.1.

Place the SUCTION HOSE into a pail of glycol as in Fig 5.2.

Fig 5.2



6) Using a screwdriver, DEPRESS the poppet (Fig 6.1) inside the QUICK COUPLER on the FILL HOSE with the pump running and the 1/2" BALL VALVE OPEN. Hold the poppet open until you get a steady stream of HTF from the QUICK COUPLER. Turn pump OFF. This is necessary to lubricate the rubber diaphragm in the pump. In the future the pump will self-prime.

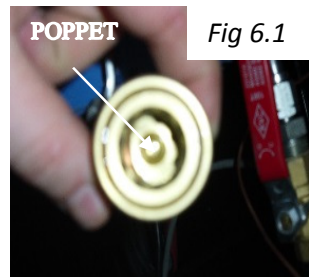

Fig 6.1

CONNECT the QUICK COUPLER to the NIPPLE and leave connected for normal operation. CLOSE the 1/2" BALL VALVE. This is shown in Fig 6.2.

- 7) Affix instructional/operational decal (Part #22 in diagram) for the Kit on the inside of the Driver's side door near the pump. See Fig. 5.2.

**Installation is now complete.**

**Fill unit with HTF to the appropriate level as indicated on the sight gauge.**

Shown on next page is a full parts breakdown of the Retrofit Kit.

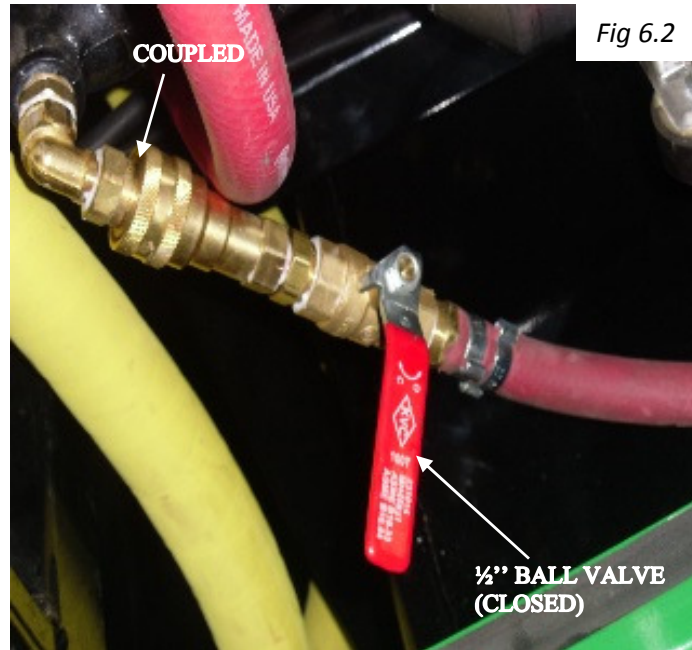



ITEM NO.	PART NUMBER	DESCRIPTION	QTY
1	004-903244 BRKT MNT SHURFLO PUMP KIT GTS		1
2	012-501619 PUMP SHURFLO 2088-594-154		1
3	004-903247 BRKT SPRT SWITCH SHURFLO PUMP KIT GTS 300		1
4	002-703253 BOX ELCC WITH REE 1-2 IN. HUB		1
5	002-701359 SWITCH TOGGLE SPST 20A 125V		1
6	002-704247 CONNECTOR 1-2 90DEG FLEX NYL	Pump Supply Connection to Electrical Box	1
7	002-704262 CONN STRN RLF PG13-5 .24-.47 CE- CSA	Power Supply Connection to Electrical Box	1
8	002-700035 PLUG CORD YEL 3PR 120V		1
9	013-703543 HOSE 1-2 RED	2x 6' Lengths	12
10	002-702645 CABLE TOW 14-3 300V CSA		6
11	011-500478 COPPER BRKS NYL		1
12	011-500480 COPPER NYL 1-2 IN. SWL		2
13	011-500482 COPPER NYL 1-2 IN. SWL		2
14	011-500484 COPPER NYL 1-2 IN. SWL		2
15	011-500486 COPPER NYL 1-2 IN. SWL		2
16	011-500488 COPPER NYL 1-2 IN. SWL		2
17	011-500490 COPPER NYL 1-2 IN. SWL		2
18	011-500492 COPPER NYL 1-2 IN. SWL		2
19	011-500494 COPPER NYL 1-2 IN. SWL		2
20	011-500496 COPPER NYL 1-2 IN. SWL		2
21	011-500498 COPPER NYL 1-2 IN. SWL		2
22	011-500500 COPPER NYL 1-2 IN. SWL		2
23	002-700925 TERM RING END 16/14 BLU		4
24	002-800012 MARRET LOCK ORN	Connect to Screw Terminals in Electrical Box	1
25	003-903232 DECAL HTF PUMP GTS 300	Connect Neutral in Electrical Box	1
26	001-702552 CLP 2-EAR #22SS - 1-2ID HOSE	Double Clamp Pressure Hose	5
27	011-903224 ELB ST 3-8X90DEG BR5 NPT	Single Clamp Suction Hose	1

ISOMETRIC VIEW

FRONT VIEW

SIDE VIEW

NOTES:  
 ITEM #22 TO BE AFFIXED TO UNIT IN EASILY VISIBLE POSITION.  
 ITEM #27 TO BE INSTALLED AS PER RETROFIT INSTRUCTIONAL SHEET.  
 ITEM #23 AND ITEM #24 WILL NOT BE VISIBLE. THEY ARE WIRED IN THE SWITCH BOX.  
 ITEM #9 IS CUT INTO 2x 6' HOSES.  
 THE SUCTION HOSE ON THE INTAKE SIDE OF THE PUMP THE FILL HOSE ON THE DISCHARGE SIDE OF THE PUMP

PROCESS	DESCRIPTION	R #	DATE	REVISION	ECO BY	PART #	MATERIAL	QUANTITY
ASSEMBLY	DONE AT DRYAIR							
INSTALL	DONE IN FIELD							
UNLESS OTHERWISE SPECIFIED DIMENSIONS ARE IN INCHES TOLERANCES ARE: FRACTIONS DECIMALS ANGLES $\pm 1/16"$ $\pm 0.010$ $\pm 1'$								
THE INFORMATION CONTAINED IN THIS DRAWING IS THE SOLE PROPERTY OF DRYAIR. ANY REPRODUCTION OR TRANSMISSION OF THIS INFORMATION WITHOUT WRITTEN PERMISSION IS STRICTLY PROHIBITED.								
DRAWING # <b>018-903245</b>								DRAWN BY: RB CHECKED BY: RB SCALE: 1:4 DWG SIZE: B
DRYAIR BOX 105, ST. BREUX, SK CANADA, S6K 3J0 TEL: (506) 274-4666 FAX: (506) 274-4664								DESCRIPTION: 018-903245 PFG FILL PUMP SHURFLO RETROFIT DATE: 01/22/16

---

# Service Bulletin

**To:** All Dryair Customers  
**From:** Dryair Service Dept.  
**Date:** February 3, 2016  
**Bulletin #:** SB 1604  
**Re:** Multiquip Generator Enhancement  
**Models Affected:** GTS 300 with Multiquip Generators

---

**P/N 000-903265 PKG Step-Down Cord L5-30PX5-15R.**

Purpose:

To utilize more of the Multiquip generator's power supply. This will enable the end-user to operate the hose reel and heat exchanger at the same time.

Terms:

Dryair will provide, at No Charge, the Step-Down Cord, complete with all the necessary hardware. This will include freight (by ground transportation).

Dryair will cover labor of up to One Hour to install. Travel is NOT covered.

When installation is complete, please fill out the attached warranty claim report to receive credit.

Ordering Information:

Part Number 00-903265

Canada

Parts dept.

Toll free (888)-750-1700

Local (306)-275-4848 ext. 2406

Fax (306)-275-4664

For any technical assistance and / or support please call;  
Canada Toll Free 1-888-750-1700  
Local (306)275-4848

## GENERATOR STEP-DOWN CORD KIT

000-903265 PKG STEP-DOWN CORD L5-30PX5-15R



This Kit is designed to allow simultaneous operation of the Hose Reel and the Water Heater on the GTS 300 when equipped with a generator. This is achieved by connecting to an alternate circuit through a NEMA L5-30R power receptacle. Such a receptacle exists on the Multiquip WhisperWatt 7000 generator. It can be identified as the receptacle matching *Fig 1*. Power exits this connection at 120VAC at 30A. The purpose of this Kit is to step this high amperage down to the required 15A and provide current protection to the output circuit.



This Kit will also free up one of the outlets on the standard duplex 5-15R GFCI receptacle set on the generator that was formerly used to power the Hose Reel on the GTS 300.

The Kit is equipped with a magnetic base, allowing for easy positioning on the unit. DRYAIR recommends mounting on the back side of the generator. A parts breakdown is shown in *Fig 2*.

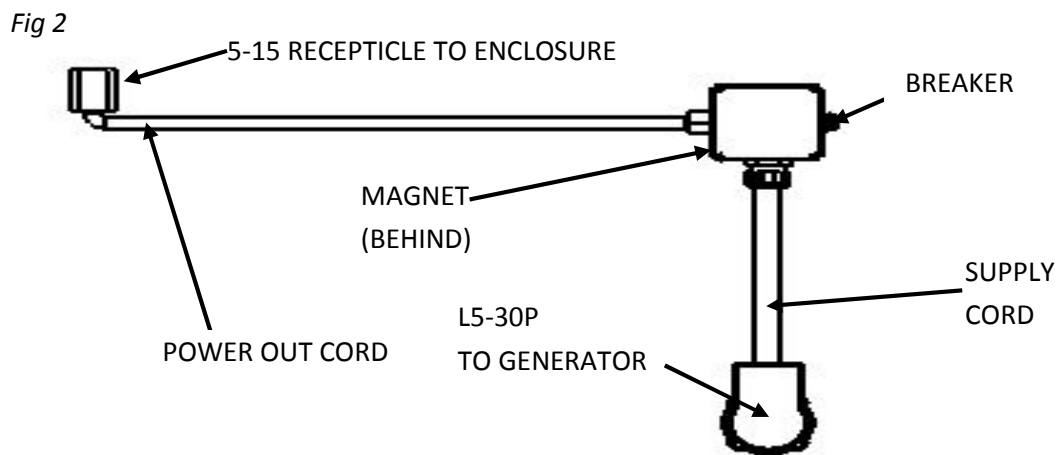

After positioning the Kit on the unit, connect the POWER OUT CORD to the Hose Reel outlet on the GTS 300 (the top connection on the GTS 300 enclosure). Next, connect the SUPPLY CORD to the L5-30R receptacle on the generator. See *Fig 1* to identify this receptacle.

Congratulations, your Kit is now installed and operational.