

PRODUCT/TECHNICAL BULLETIN

System 350™ W351 Electrical On/Off Humidity Control

The W351 Electronic Humidity Control is an On/Off humidity control. The control output is a Single-Pole, Double-Throw (SPDT) relay with LED indication. It features humidification and dehumidification modes of operation and an adjustable differential.

The W351 control is designed to work with an HE-67S3-0N0BT Room Sensor Humidity Transmitter or HE-67S3-0N00P Duct Sensor Humidity Transmitter.

As with all System 350 products, the W351 control housing is a compact NEMA 1, high-impact plastic enclosure. The modular design provides easy, plug-together connections for quick installation and future expandability.



Figure 1: W351 Electronic On/Off Humidity Control

Features and Benefits	
<input type="checkbox"/> Modular Design	Provides the flexibility to add up to five S351 Humidity Stage Modules (nine with a 24 VAC transformer), a D351 Humidity Display Module, and a Y350R Power Module
<input type="checkbox"/> Plug-together Connectors and 35 mm DIN Rail Mounting	Eliminates wiring between modules and reduces installation costs
<input type="checkbox"/> Adjustable Setpoint Range of 10-90% RH	Reduces inventory by covering the humidity range required to support most humidity applications
<input type="checkbox"/> Wide Adjustable Differential of 2-10% RH	Enables the user to match the equipment cycle rate and sequencing for a given application
<input type="checkbox"/> Humidification or Dehumidification Modes of Operation	Works in a variety of humidification or dehumidification applications
<input type="checkbox"/> Interchangeable Humidity Transmitters	Increases versatility and serviceability

Application

IMPORTANT: Use this System 350 W351 Electronic On/Off Humidity Control only to control equipment under normal operating conditions. Where failure or malfunction of the W351 control could lead to personal injury or property damage to the controlled equipment or other property, additional precautions must be designed into the control system. Incorporate and maintain other devices, such as supervisory or alarm systems or safety or limit controls, intended to warn of or protect against failure or malfunction of the W351 control.

IMPORTANT : Utiliser ce System 350 W351 Electronic On/Off Humidity Control uniquement pour commander des équipements dans des conditions normales de fonctionnement. Lorsqu'une défaillance ou un dysfonctionnement du W351 control risque de provoquer des blessures ou d'endommager l'équipement contrôlé ou un autre équipement, la conception du système de contrôle doit intégrer des dispositifs de protection supplémentaires. Veiller dans ce cas à intégrer de façon permanente d'autres dispositifs, tels que des systèmes de supervision ou d'alarme, ou des dispositifs de sécurité ou de limitation, ayant une fonction d'avertissement ou de protection en cas de défaillance ou de dysfonctionnement du W351 control.

The W351 Electronic On/Off Humidity Control can be used as a standalone device or in conjunction with System 350 Add-On Modules to control a wide variety of single or multiple stage humidity applications. Typical W351 control applications include humidity control for:

- clean rooms
- computer rooms
- pharmaceutical manufacturing
- fruit storage/ripening
- indoor swimming pools
- greenhouses

A typical System 350 Humidity Control scheme includes the following:

- W351 Humidity Control
- up to five S351 Humidity Stage Modules
- D351 Digital Humidity Display Module
- Y350R Power Module (or 24 VAC transformer)

- HE-67S3-0N0BT Wall Mount or HE-67S3-0N00P Duct Mount Humidity Transmitter

Operation

The W351 control has an external range scale and setpoint dial, a front panel LED indicating when the relay is energized, and a SPDT relay output. (See Figure 2.) Features include:

- adjustable setpoint
- adjustable differential
- selectable mode of operation (humidification/dehumidification)

Setpoint Adjustment

Setpoint is the % RH at which the relay de-energizes. With the operation mode jumpers in either the humidification or dehumidification position, the relay de-energizes when the % RH at the transmitter reaches the setpoint.

Differential Adjustment

Differential is the change in % RH at the transmitter required to energize and de-energize the relay. The differential is adjustable between 2-10% RH.

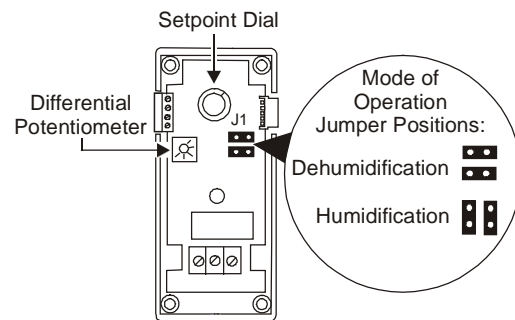

Figure 2: W351 Electronic On/Off Humidity Control; Setpoint and Differential Adjustments; Humidification and Dehumidification Modes

Mode of Operation

When the dehumidification mode is selected, the differential is above the setpoint. When the humidity rises to the setpoint plus the differential setting, the relay energizes and the LED lights. When the humidity drops to the setpoint, the relay and LED indicator de-energize. (See Figure 3.)

When the humidification mode is selected, the differential is below the setpoint. When the humidity drops to the setpoint minus the differential setting, the relay energizes and the LED lights. When the humidity rises to the setpoint, the relay and LED indicator de-energize. (See Figure 3.)

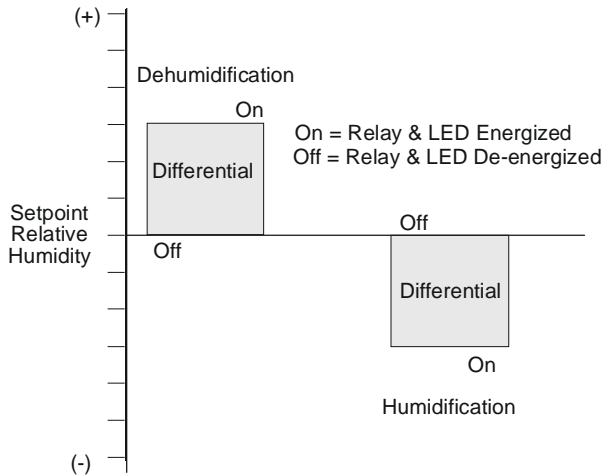

Figure 3: Modes of Operation

Dimensions

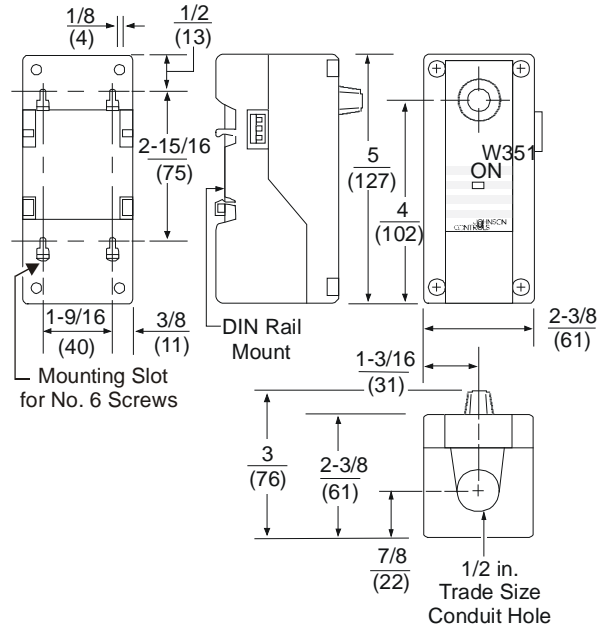

Figure 4: W351 Control Dimensions, in./mm

Mounting

The W351 Electronic Humidity Control housing is a compact NEMA 1 plastic enclosure designed for standard 35 mm DIN rail mounting. Four key-slot mounting holes on the back of the control case are provided for surface mounting.

The W351 control is not position sensitive but should be mounted for convenient wiring and adjustment.

Note: When mounting the W351 control (or any System 350 module) to rigid conduit, attach the hub to the conduit before securing the hub to the control enclosure.

**WARNING: Risk of Electric Shock.**

Disconnect or isolate all power supplies before making electrical connections. More than one disconnection or isolation may be required to completely de-energize equipment. Contact with components carrying hazardous voltage can cause electric shock and may result in severe personal injury or death.

AVERTISSEMENT : Risque de décharge électrique.

Débrancher ou isoler toute alimentation avant de réaliser un branchement électrique. Plusieurs isolations et débranchements sont peut-être nécessaires pour couper entièrement l'alimentation de l'équipement. Tout contact avec des composants conducteurs de tensions dangereuses risque d'entraîner une décharge électrique et de provoquer des blessures graves, voire mortelles.

Wiring

Install all wiring to conform to the National Electrical Code and to local regulations. For maximum electrical rating of control, refer to the label inside the control cover. Use only copper conductors.

See Figures 5 and 6 for proper wiring and terminal designations.

Transmitter Wiring

The W351 Humidity Control uses an HE-67S3-0N0BT or HE-67S3-0N00P Humidity Transmitter, which is powered by the 12 VDC power supply from the W351 control. See *TRUERH™ Series HE-67xx Humidity Element with Temperature Sensor Installation Instructions (Part No. 24-9527-7 Rev. A)* for more information.

Connect the transmitter to the W351 control at the four-conductor screw terminal block, located at the upper left of the circuit board. (See Figures 5 and 6.)

Note: Set the output jumpers on the HE-67S3-0N0BT and HE-67S3-0N00P humidity transmitters for 0 to 10 VDC output.

Shielded cable is not generally required for transmitter wiring on runs of less than 50 feet. When using shielded cable, isolate and tape the shield at the transmitter. Connect the shield to the Communications Port (COM) terminal on the W351 control.

The maximum recommended length of 22 AWG 3-wire shielded transmitter cable is 250 feet (76 meters).

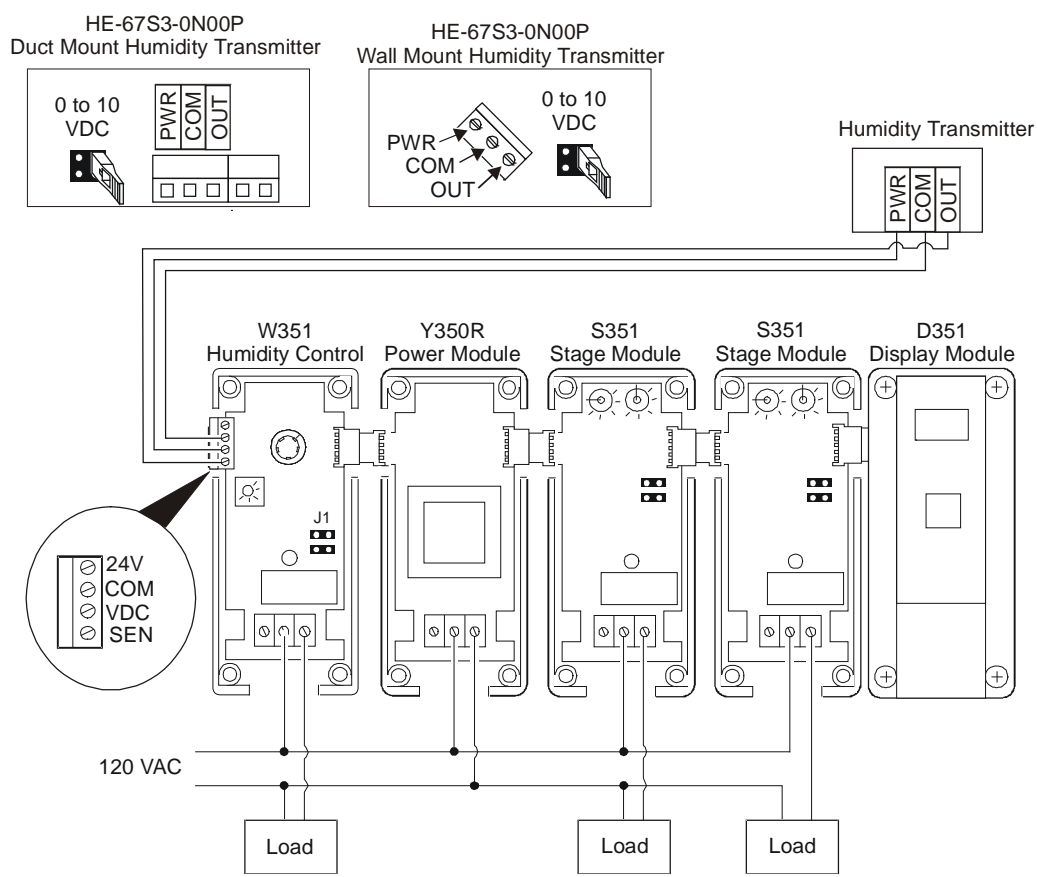

Figure 5: W351 Humidity Control (Dehumidification Mode) Powered by an External Transformer with the Humidity Transmitter Less Than 50 Feet from the W351 Control

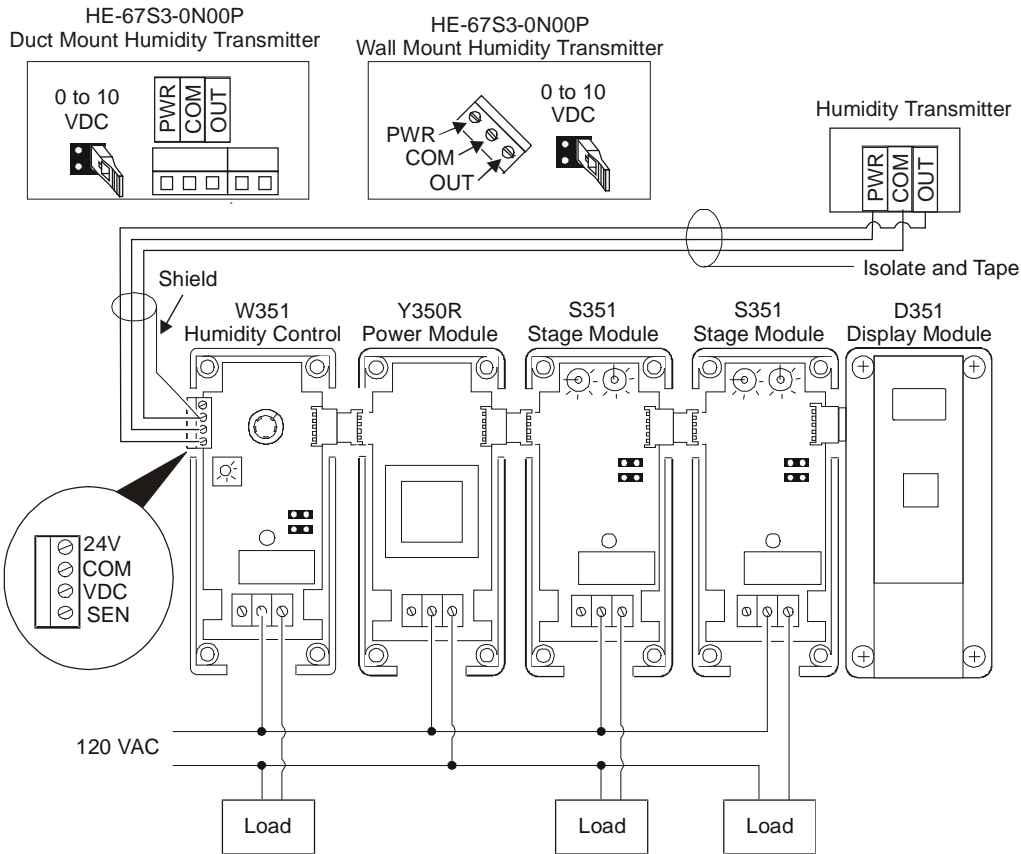

Figure 6: System 350 Modules Powered by a Y350R Power Module with the Humidity Transmitter 50-250 Feet from the W351 Control

Add-On Modules

The S351 Stage Modules, D351 Digital Humidity Display Modules, and Y350R Power Modules plug together and connect to the W351 Electronic Humidity Control via connectors on the sides of each add-on module. The recommended order of the modules is shown in Figures 5 and 6.

S351 Humidity Stage Modules

The S351 Stage Modules receive their power, setpoint, and sensor input from the W351 Electronic Humidity Control.

When using a Y350R module, up to five additional S351 Stage Modules can be plugged into a W351 Humidity Control. When using an external 24 VAC (40 VA minimum) transformer, up to nine additional S351 Stage Modules can be plugged in.

See *System 350™ S350A Temperature, S351A Humidity, and S352A Pressure Stage Modules Product/Technical Bulletin (LIT-930080)* for more information.

D351 Digital Humidity Display Module

The D351 Display Module receives its power, sensor, and setpoint information from the W351 control. A 3-digit Liquid Crystal Display (LCD) gives a continuous display of the sensed humidity. Press the button to display the setpoint of the adjoining W351 control. See *System 350™ Display Modules Product/Technical Bulletin (LIT-930070)* for more information.

Y350R Power Module

The Y350R Power Module provides a convenient method of powering System 350 modules from a 120 or 240 VAC power source.

Plug the Y350R power module into the right side of the W351 Electronic Humidity Control. The Y350R power supplies power for a W351 control, a D351 Display Module, and up to five S351 Stage Modules.

See *System 350™ Power Module Product/Technical Bulletin (LIT-930090)* for more information.

Adjustments



WARNING: Risk of Electric Shock.

Do not touch any exposed metal parts with anything other than properly insulated tools or insulated probes of the digital voltage meter. Failure to use properly insulated tools and probes may result in severe personal injury or death.

AVERTISSEMENT : Risque de décharge électrique.

Ne jamais toucher une partie métallique exposée avec tout élément autre que des outils correctement isolés ou les sondes isolées du voltmètre numérique. L'utilisation d'outils et de sondes incorrectement isolés risque de provoquer des blessures graves, voire mortelles.

IMPORTANT: Verify that the humidification/dehumidification operation mode jumpers are in the proper position before powering System 350 components. If the operation mode jumpers on the control or the staging modules are left in the wrong position, the device will activate the relay in response to the opposite signal. The humidifying or dehumidifying equipment may remain energized until the error is corrected.

W351 Control

1. Remove the W351 control cover by loosening the four captive cover screws.
2. Position the jumpers on jumper block **J1** vertically for humidification, or horizontally for dehumidification. (See Figure 2.) The jumpers are factory-set for humidification.

3. Adjust the differential by rotating the differential potentiometer to the desired setting. (See Figure 2.) Rotate the potentiometer clockwise to increase the differential.
4. Replace the cover, tighten the four captive cover screws, and adjust the setpoint by rotating the setpoint dial to the desired % RH setpoint. (See Figure 2.)

Note: Use the D351 Display Module for the most accurate setpoint selection.

If using the D351 Display Module, press and hold the button on the D351 module while rotating the setpoint dial.

S351 Stage Module

When the W351 control is used in conjunction with one or more S351 modules, the following adjustments must be made to each S351 module. Additional information about adjusting the stage module is available in the *S350 Temperature, S351 Humidity, and S352 Pressure Stage Modules Product/Technical Bulletin (LIT-930080)*.

1. Remove the S351 module cover by loosening the four captive cover screws.
2. Set the humidification/dehumidification operation mode jumpers to the desired mode of operation.
 - Select dehumidification mode for offset and differential above setpoint. (See Figures 7 and 8.)
 - Select humidification mode for offset and differential below setpoint. (See Figures 7 and 8.)
3. Adjust the S351 stage module's offset potentiometer to the desired offset value. The offset value is the difference in humidity from the W351 control module's setpoint that is required for the S351 stage module's relay to de-energize. (See Figures 7 and 8.)

4. Adjust the differential potentiometer to the desired differential value. The differential value is the difference in humidity from the offset that is required for the S351 stage module's relay to energize. (See Figures 7 and 8.)
5. Reinstall the cover onto the enclosure base and secure the cover to the enclosure base with the four cover screws.

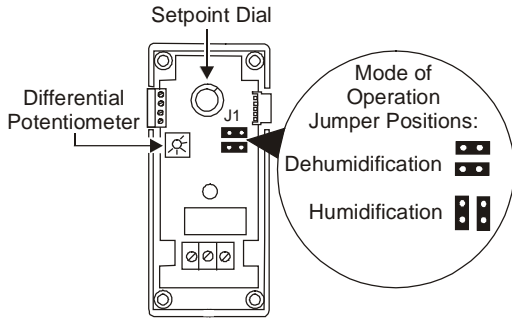

Figure 7: S351 Stage Module Adjustment and Potentiometer Locations

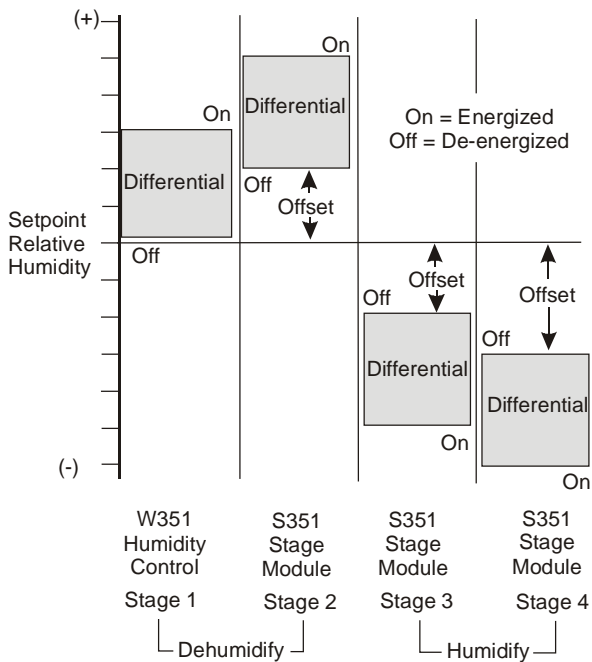

Figure 8: Typical Multistage Humidification/Dehumidification Application

Troubleshooting

Before applying power, make sure installation and wiring connections are according to job specifications.

After making necessary adjustments and electrical connections, put the system into operation and observe at least three complete operating cycles before leaving the installation.

Checkout



WARNING: Risk of Electric Shock.

Do not touch any exposed metal parts with anything other than properly insulated tools or insulated probes of the digital voltage meter. Failure to use properly insulated tools and probes may result in severe personal injury or death.

AVERTISSEMENT : Risque de décharge électrique.

Ne jamais toucher une partie métallique exposée avec tout élément autre que des outils correctement isolés ou les sondes isolées du voltmètre numérique. L'utilisation d'outils et de sondes incorrectement isolés risque de provoquer des blessures graves, voire mortelles.

If the control system does not function properly, verify that the proper mode is selected on each module (e.g., humidification/dehumidification) and then use the following procedures to determine the cause of the problem:

1. Check for proper voltage applied to the W351 Humidity Control:
 - a. Connect a Digital Voltmeter (DVM) between the 24 V (+) and COM (-) terminals located on the W351 control's left-side terminal block. (See Figures 5 and 6.)
 - If an external transformer is used, select AC volts on the DVM and verify that the voltage is between 20-30 VAC.
 - If a Y350R Power Module is used, select DC volts on the DVM and verify that the voltage is between 16-38 VDC.
 - b. Proceed to Step 2 if the DVM reading is within the indicated voltage range.
 - c. If the DVM reading is **not** within the indicated voltage range, check wiring, then replace the

Y350R power module or the external transformer.

Table 1: W351 Control Relay Troubleshooting

Mode of Operation	LED Status	Normally Open Relay Status	Setpoint Dial Setting*
Humidify	On	Closed	$(RH_T) + \text{differential}$
Humidify	Off	Open	(RH_T)
Dehumidify	On	Closed	$(RH_T) - \text{differential}$
Dehumidify	Off	Open	(RH_T)

* See Figure 9 for RH_T vs. Humidity illustration.

2. Check humidity transmitter for proper output voltage:

- a. Disconnect the transmitter OUT wire from the W351 control SEN terminal.
- b. Take a humidity reading with a properly calibrated, accurate humidity measuring device. This reading is the actual humidity.
- c. Connect a DC voltmeter between the transmitter OUT wire and the control COM terminal. Using Figure 9, convert the voltage to % RH. This is the humidity reading at the transmitter (RH_T).

Note: A transmitter output of 0-10 VDC should correspond to a humidity of 0-100% RH (see Figure 9).

- If the RH_T is close to the actual humidity, proceed to Step 2d.
 - If the RH_T deviates substantially from the actual humidity, replace the transmitter.
- d. Reconnect the transmitter OUT wire to the W351 control SEN terminal.

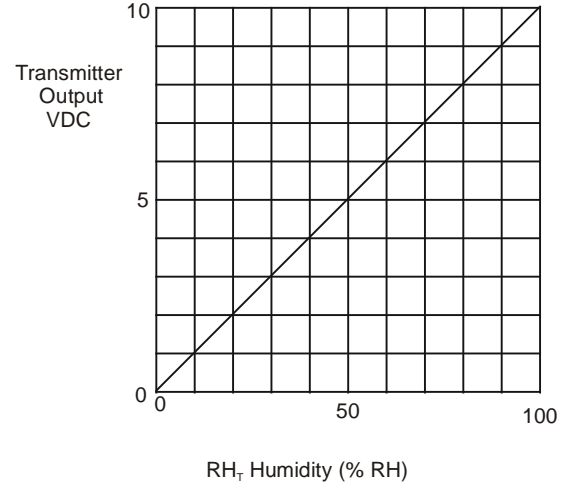

Figure 9: Transmitter Voltage vs. Humidity

3. Check the W351 Electronic Humidity Control for proper operation:

Note: Perform Steps 1 and 2 first.

- a. Adjust the setpoint dial to at least 20% RH below the voltage conversion to % RH (RH_T) as determined in Step 2.
- b. Increase the setpoint by slowly adjusting the dial until the W351 control's relay and LED turn On and Off as shown in Table 1.
- c. If the relay performs as expected, continue to Step 4.
- d. If the relay does **not** perform as indicated in Table 1, replace the W351 control.

4. Check the S351 Stage Modules for proper operation (if applicable):

Note: Perform Steps 1, 2, and 3 first.

IMPORTANT: There is a possibility that a defect in one stage module could cause defective symptoms in all modules. Plug each S351 module into the W351 control individually and check its performance as outlined in Step 4.

- a. Turn the setpoint dial on the W351 control to 10% RH (the extreme counterclockwise position).
- b. Increase the setpoint by slowly adjusting the dial until the S351 module's relay and LED turn On and Off as shown in Table 2.
- c. If the relay does not perform as indicated in Table 2, adjust the S351 module's differential and offset potentiometers to their minimum settings and try again.
- d. If the relay still does not turn On and Off, replace the defective S351 Stage Module(s).

Table 2: S351 Module Relay Troubleshooting

Mode of Operation	LED Status	Normally Open Relay Status	Setpoint Dial Setting*
Humidify	On	Closed	$(RH_T) + \text{offset} + \text{differential}$
Humidify	Off	Open	$(RH_T) + \text{offset}$
Dehumidify	On	Closed	$(RH_T) - \text{offset} - \text{differential}$
Dehumidify	Off	Open	$(RH_T) - \text{offset}$

* See Figure 9 for RH_T vs. Humidity illustration.

5. Check the D351 Display Module for proper operation (if applicable):

Note: Perform Steps 1 through 4 first.

- a. Compare the voltage conversion to % RH at the transmitter (RH_T) (as determined in Step 2) with the display readout.
- b. If the D351 module does not read the correct transmitter RH (RH_T), replace the D351 module.
- c. Press the button on the D351 module to display the setpoint.
- d. If pressing the button results in an out-of-range reading (greater than 100% RH), replace the D351 module.
- e. If pressing the button results in a reading other than the expected setpoint value, check the setpoint dial setting on the W351 control and correct if necessary. If the display continues to show an incorrect value, replace the display module.

Note: If the W351 control and add-on modules all appear to be operating properly, but the field device still does not turn On and Off as expected, check the wiring from the W351 control or S351 module to the field device.

Repairs and Replacement

Do not calibrate or make field repairs. HE-67S3-0N0BT and HE-67S3-0N00P humidity transmitters and replacement controls are available through local Johnson Controls representatives or wholesale distributors.

Ordering Information

Table 3: Ordering Information

Item	Product Code Number	Description
Electronic Humidity Control	W351AB-2C	Setpoint Range: 10-90% RH Differential: 2-10% RH (sensor not included)
	W351AA-1C	Setpoint Range: 10-90% RH Differential: 2-10% RH (includes Wall Mount Sensor HE-67S3-0N0BT)
	W351AA-2C	Setpoint Range: 10-90% RH Differential: 2-10% RH (includes Duct Mount Sensor HE-67S3-0N00P)
Humidity Transmitter	HE-67S3-0N0BT	All-polymer, Wall Mount Humidity Transmitter
	HE-67S3-0N00P	All-polymer, Duct Mount Humidity Transmitter
Display Module	D351AA-1C	Digital Humidity Display Module
Stage Module	S351AA-1C	Humidity Stage Module with % RH Scale
Power Module	Y350R-1C	Rectified, Class 2, 24 VAC from 120/240 VAC Source
Conduit Adapter	ADP11A-600R	1/2-in. Snap-fit Connector (box of 10)
DIN Rail Sections	BKT287-1R	35 x 7.5 mm, 0.305 m (12 in.) long
	BKT287-2R	35 x 7.5 mm, 0.914 m (36 in.) long
DIN Rail End Clamps	PLT344-1R	Consists of Two End Clamps
Cable for Remote Mounting of D351 Display Module	WHA29A-600R	(0.9 m) 3 ft*
	WHA29A-603R	(7.6 m) 25 ft
	WHA29A-604R	(15.2 m) 50 ft

* WHA29A-600R can also be used to daisy chain S351 Stage Modules together.

Specifications

Product	W351 Electronic On/Off Humidity Control		
Humidity Setpoint Range	10-90% RH		
Differential Range	2-10% RH		
Input Signal	0-10 VDC Corresponding to 0-100% RH		
VDC Power Supply	12 VDC Provided to Power the Humidity Transmitter		
Supply Voltage*	20-30 VAC Class 2; 50/60 Hz (or a Y350R Power Module: See <i>Add-On Modules</i> section)		
Power Consumption	1.8 VA maximum		
Relay Electrical Ratings	Horsepower:	1/2 (120/240 VAC)	
	Full Load Amperes:	9.8 (120 VAC)	4.9 (208/240 VAC)
	Locked Rotor Amperes:	58.8 (120 VAC)	29.4 (208/240 VAC)
	Non-inductive Amperes:	10 at 24/240 VAC	
	Pilot Duty:	125 VA at 24/240 VAC	
Ambient Temperature	Operating:	-30-150°F (-34-66°C)	
	Shipping:	-40-185°F (-40-85°C)	
Ambient Humidity	0-95% RH Non-Condensing; Maximum Dewpoint 85°F (29°C)		
Material	Case, Cover:	NEMA 1 High-impact Thermoplastic	
Agency Listing	UL Listed, File E27734, CCN XAPX cUL Listed, File E27734, CCN XAPX7		
Transmitter	HE-67S3-0N0BT: All-Polymer, Wall-Mount Humidity Transmitter; 0 to 10 VDC, 0 to 100% RH HE-67S3-0N00P: All-Polymer, Duct-Mount Humidity Transmitter; 0 to 10 VDC, 0 to 100% RH		
Add-On Modules		Supply Voltage:	Provided by the W351 control
	S351	DIFF and OFFSET:	2-10% RH Differential; 2-30% RH Offset
	Y350R	Supply Voltage:	Provided by the W351 control
	D351	Display Range:	10-90% RH

* Only one input voltage source may be used.

The performance specifications are nominal and conform to acceptable industry standards. For application at conditions beyond these specifications, consult Johnson Controls/PENN Application Engineering at 1-800-275-5676. Johnson Controls, Inc. shall not be liable for damages resulting from misapplication or misuse of its products.



Building Efficiency
507 E. Michigan Street, Milwaukee, WI 53202

Metasys® and Johnson Controls® are registered trademarks of Johnson Controls, Inc. All other marks herein are the marks of their respective owners. © 2014 Johnson Controls, Inc.